

Exterior Wayfinding Guidelines

May 2017 (Revision 5, September 2024)

*Appendix IX to University Design Guidelines &
Performance Standards*

All signage must be approved by the
VP of University Communications and
AVP of University Planning, Design and
Construction

Contents

This document has been prepared to provide guidance for the ongoing and future implementation of the wayfinding program at UConn campuses. It summarizes key points devised during the wayfinding program development.

1.00	Contents	3.00	Construction Intent Drawings
1.01	Project Overview	3.01	Technical Specifications
2.00	Sign Type Criteria	CID.08	Primary Vehicular Directional (B1)
2.01	Vehicular Directional Sign Types	CID.15	Secondary Vehicular Directional (B2)
2.02	Parking Sign Types	CID.22	Tertiary Vehicular Directional (B3)
2.03	Pedestrian Directional Sign Types	CID.28	Primary Parking ID (D1)
2.04	Building Identification Sign Types	CID.34	Secondary Parking ID (D2)
2.05	Honorific Destination Messaging	CID.40	Walkway ID (E)
2.06	Regulatory Sign Types	CID.43	Pedestrian Campus Map Kiosk (G)
CID.02	Sign Type Family Overview	CID.50	Primary Pedestrian Directional (H1)
CID.04	Typography	CID.57	Secondary Pedestrian Directional (H2)
CID.05	Symbols	CID.64	Primary Building ID, Freestanding, Large (J0)
CID.07	Finish Schedule	CID.71	Primary Building ID, Freestanding, Small (J1)
		CID.77	Secondary Building ID, Freestanding (J2)
		CID.83	Secondary Building ID, Wall-Mounted (J3)
		CID.87	Secondary Building ID, Door-Mounted (J4)
		CID.89	Accessible Pathway Marker (K)
		CID.91	Shuttle Bus Stop ID (L)
		CID.94	Regulatory, Vehicular (P)
		CID.95	Regulatory, Pedestrian (Q1)
		CID.99	Parking ID, Pole-Mounted (Q1a)
		CID.102	Regulatory, Pedestrian, Fence-Mounted (Q2)
		CID.106	Emergency ID (R)
		4.00	Additional Details
		4.01	No-Mow Zone
		4.02	ADA Caning Element

Project Overview

The campus wayfinding system was developed in partnership with multiple departments including University Communications and University Planning, Design and Construction. It was created with the aim of unifying the campus environments and provide a strategic and logical information strategy to orient and direct visitors to and around the campus areas. This system builds upon the spirit of the newly released university brand standards.

All signage must be approved by the VP of University Communications and AVP of University Planning, Design and Construction

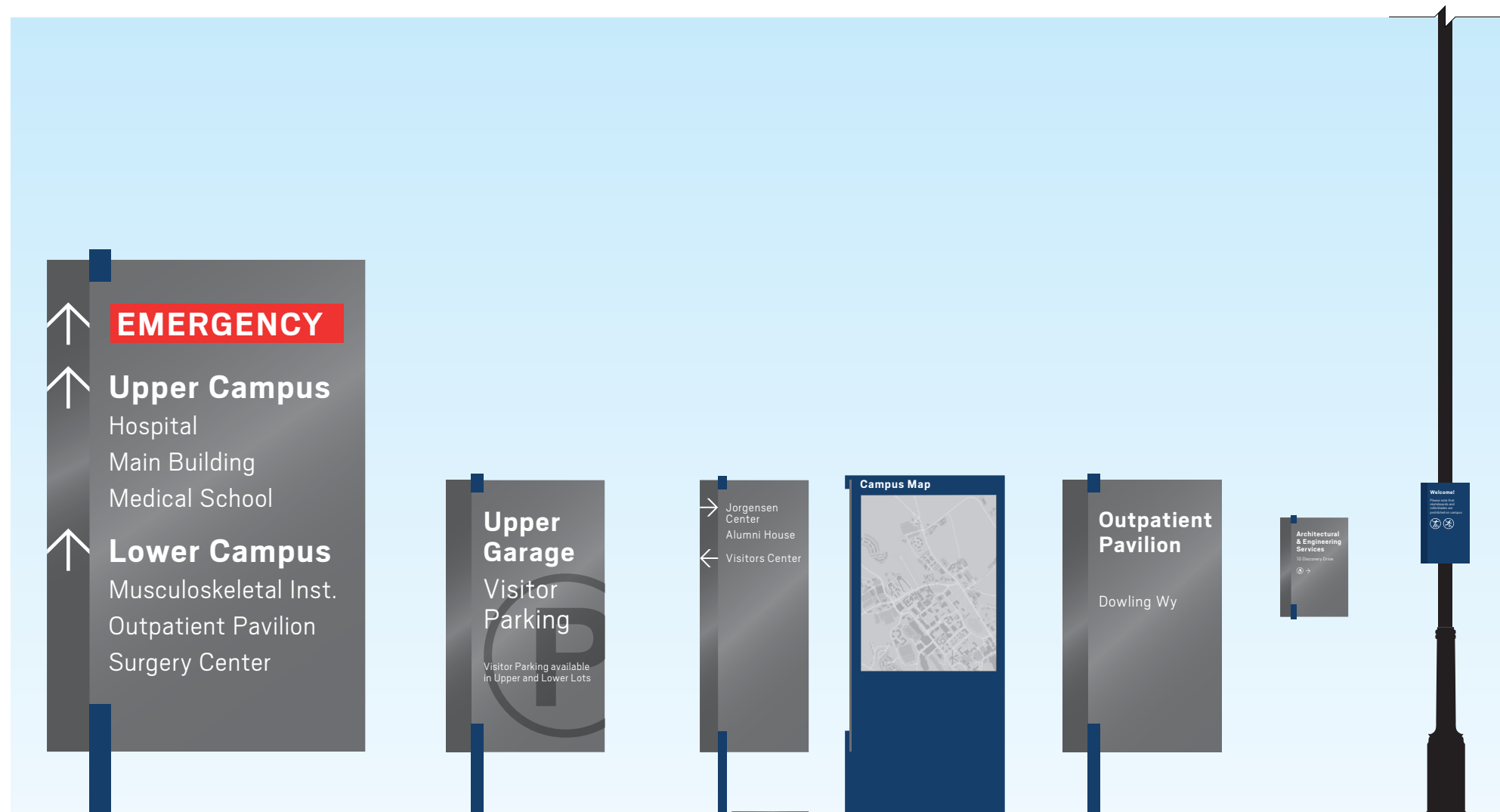

Sign Type Criteria

- 2.01 Vehicular Directional Sign Types
- 2.02 Parking Sign Types
- 2.03 Pedestrian Directional Sign Types
- 2.04 Building Identification Sign Types
- 2.05 Honorific Destination Messaging
- 2.06 Regulatory Sign Types
- CID.02 Sign Type Family Overview
- CID.04 Typography
- CID.05 Symbols
- CID.07 Finish Schedule

Vehicular Directional Sign Types

Located along the roadway, Vehicular Directional Signs direct motorists to Campus Parking Garages (at Storrs Campus) or Campus Areas (at Health Campus) and their respective / associated Primary Destinations. They also provide motorists leaving the campus with directions to neighboring Interstate and County Routes. These signs are programmed at key decision points in advance of road intersections so that adequate time is given to motorists to comprehend the information and make appropriate choices.

Sign Messaging Destination Criteria:

Storrs Campus

North Parking
Jorgensen Center
Visitor Center

South Garage
Gampel Pavilion

Storrs Center Garage
Fine Arts Complex

Health Campus

Emergency

Upper Campus
Hospital
Main Building
Medical School

Lower Campus
Musculoskeletal Institute
Outpatient Pavilion
Surgery Center

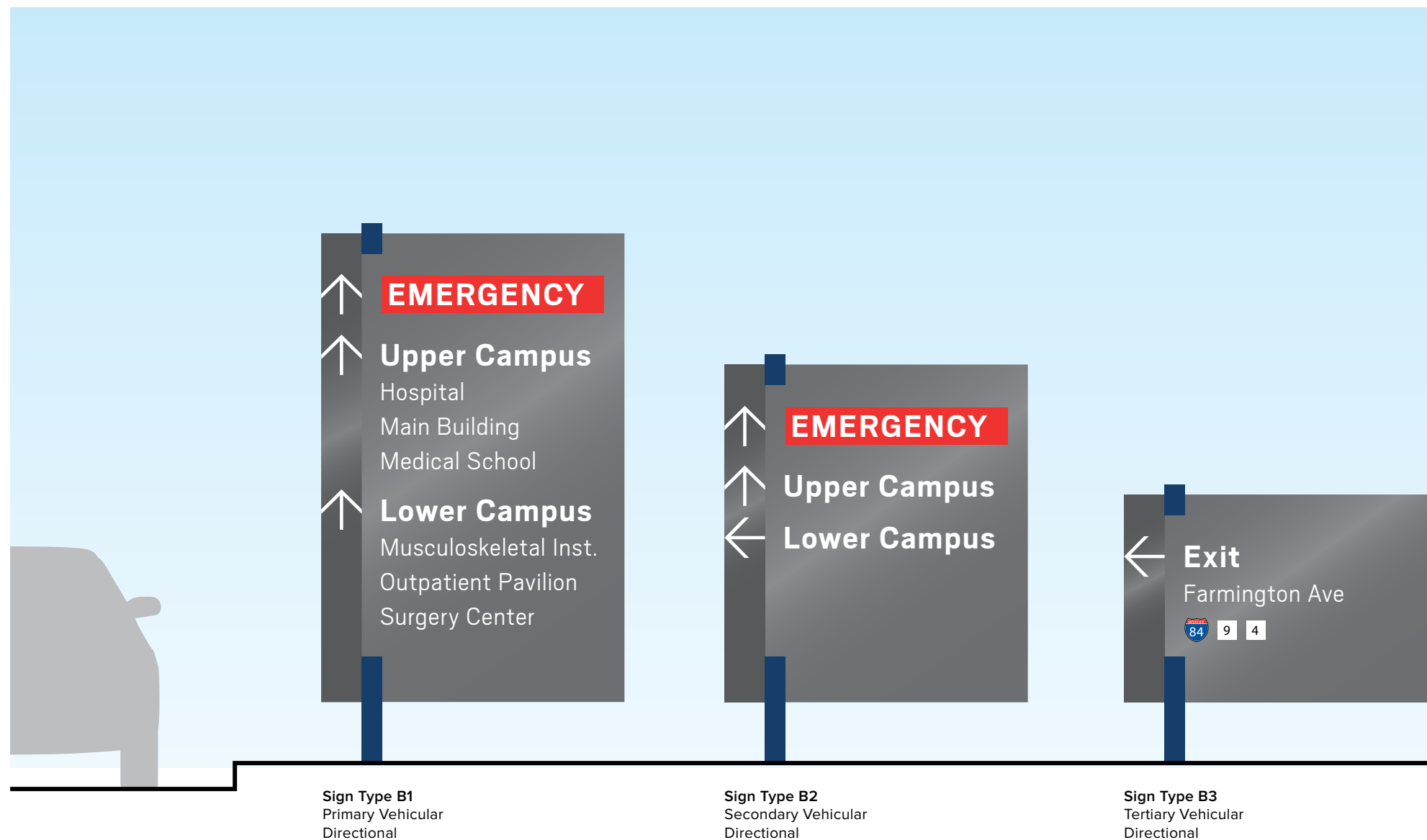

Parking Sign Types

As most visitors will be approaching the campuses in a vehicle, the secondary point in the journey will require parking before transitioning on-foot. To this end, Visitor Parking facilities are generally more prominent, while Staff / Faculty Parking facilities are less prominent. Parking Identification Signs identify the name, intended user groups, and supplementary information such as additional parking locations available on campus, or permit requirements for access.

Distinction in sign type usage between Storrs and Health. Show sign layouts for reference.

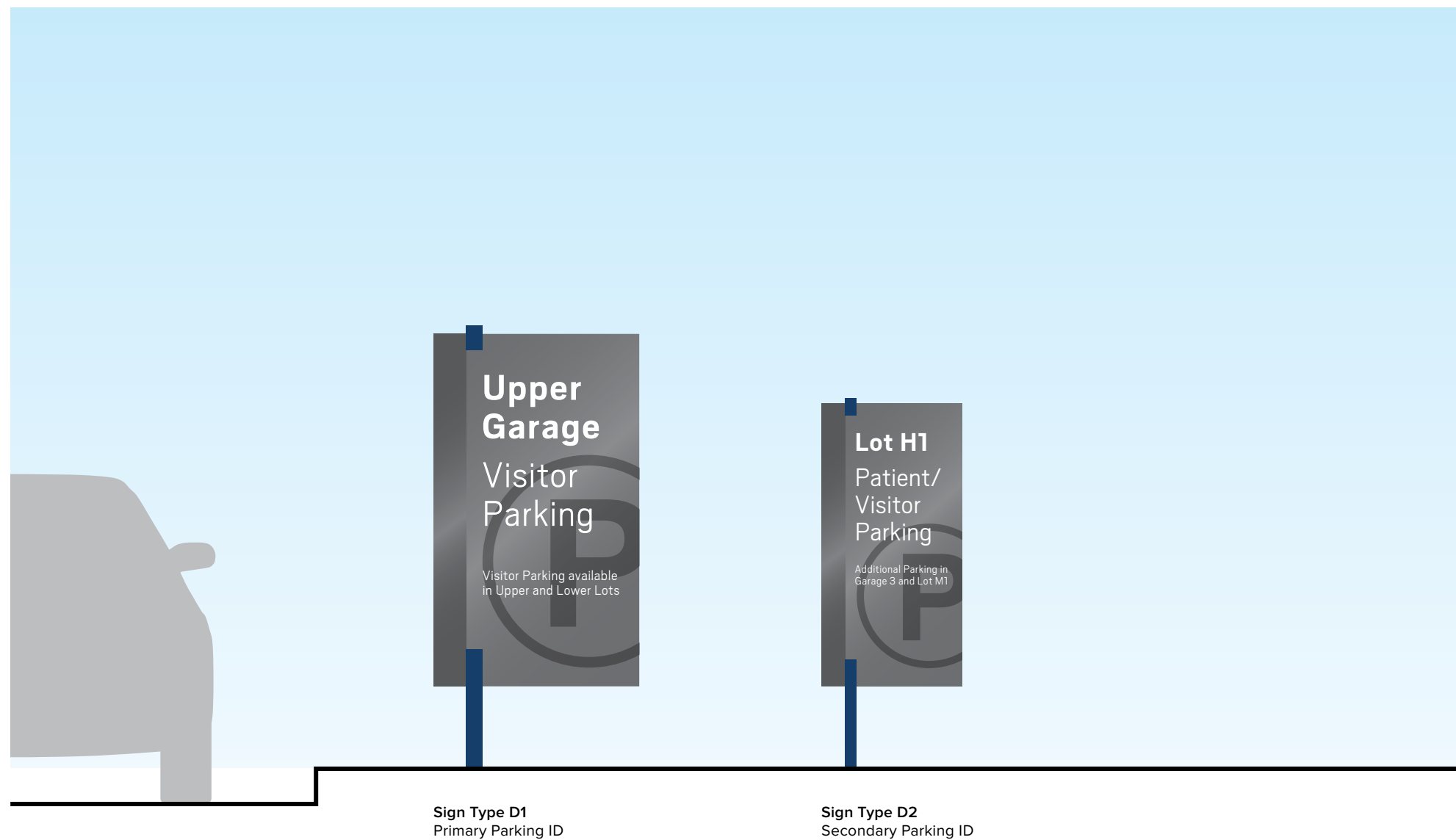

Pedestrian Directional Sign Types

Upon parking, visitors shall be oriented to their location on campus, and proceed to self-navigate to their final destination on-foot.

The Pedestrian Campus Map Kiosk is typically located outside of Visitor Parking facilities. This is a four-sided sign with an overall Campus Map and accompanying Campus Directory, a Neighborhood Map that focuses on destinations that are within a 15-minute walking distance, as well as Pedestrian Directionals to neighborhood destinations available. This sign type is also located in proximity to major visitor destinations to support secondary navigation across campus.

Pedestrian Directional Signs are typically programmed along pedestrian pathways, and located in advance of decision points and pathway intersections. General attention should be given to the placement of these signs; the directional sign panels should be perpendicular to the main path of travel to maximize sign functionality and readability in both directions of approach

Sign Messaging Destination Criteria:

Storrs Campus

North Parking
 Alumni Center
 Benton Museum
 Dairy Bar
 Jorgensen Center
 Student Union
 Wilbur Cross Building
 Visitor Center

South Garage
 Dodd Center
 Freitas Ice Forum
 Gampel Pavilion
 Homer Babbidge Library
 Morrone Stadium
 UConn Bookstore

Storrs Center Garage
 Rome Commons
 Nafe Katter Theater

Health Campus

Upper Campus
 Hospital
 Main Building
 Medical School

Lower Campus
 Musculoskeletal Institute
 Outpatient Pavilion
 Surgery Center

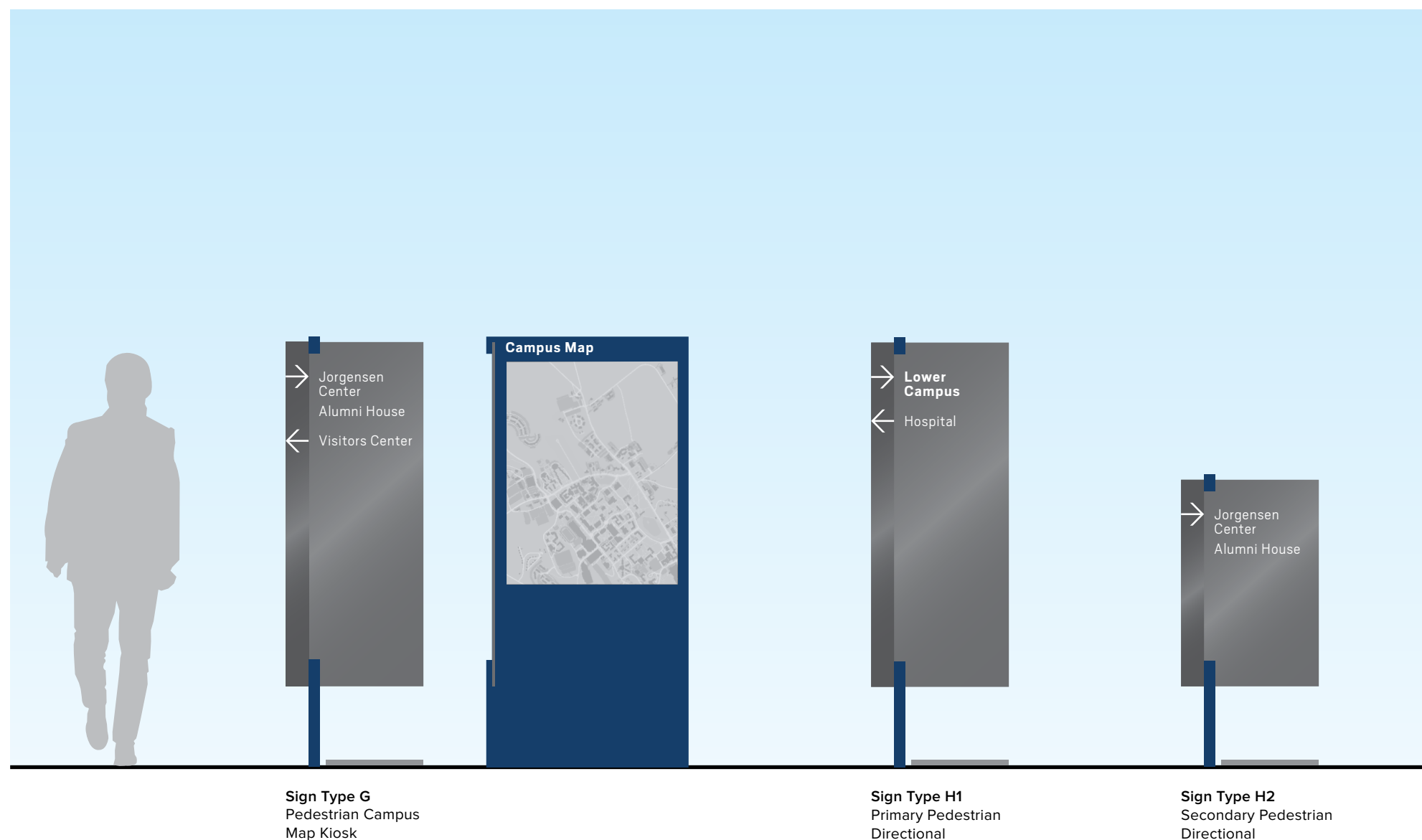

Building Identification Sign Types

Building Identification Signs inform arrival to destinations. These typically identify the building name and accompanying street address. To comply with ADA requirements, accessible entrance information is displayed to confirm accessibility.

A messaging strategy has been developed to accommodate the display of honorific / donor building names in the wayfinding system; refer to 2.05 - Honorific Destination Messaging for details of the approach.

Sign Type J0 is designated for all Destinations/Buildings at the Health Campus for maximum visibility and readability based on the anticipated vehicular approach and general campus conditions. This sign type is also designated for the prime destinations that have been identified on the Storrs Campus Vehicular Directional Signs, i.e. Visitor Center, Jorgensen Center, Gampel Pavilion, and the Fine Arts Complex.

Sign Type J1 is generally assigned to primary visitor destinations, primary academic buildings, and residential clusters. Sign type J2 is generally assigned to secondary academic buildings, offices, and residences. Sign Types J0, J1, and J2 are intended to be situated in advance of the building entrance in proximity to the general pedestrian pathway.

Sign Type J3 is programmed at the primary building entrance and displays the same information as the aforementioned freestanding sign types as a means of confirming arrival. Sign Type J4 has been developed for implementation when there is inadequate wall space for Sign Type J3.

Sign Type K is intended to be placed along accessible routes from inaccessible entrances of buildings to accessible entrances.

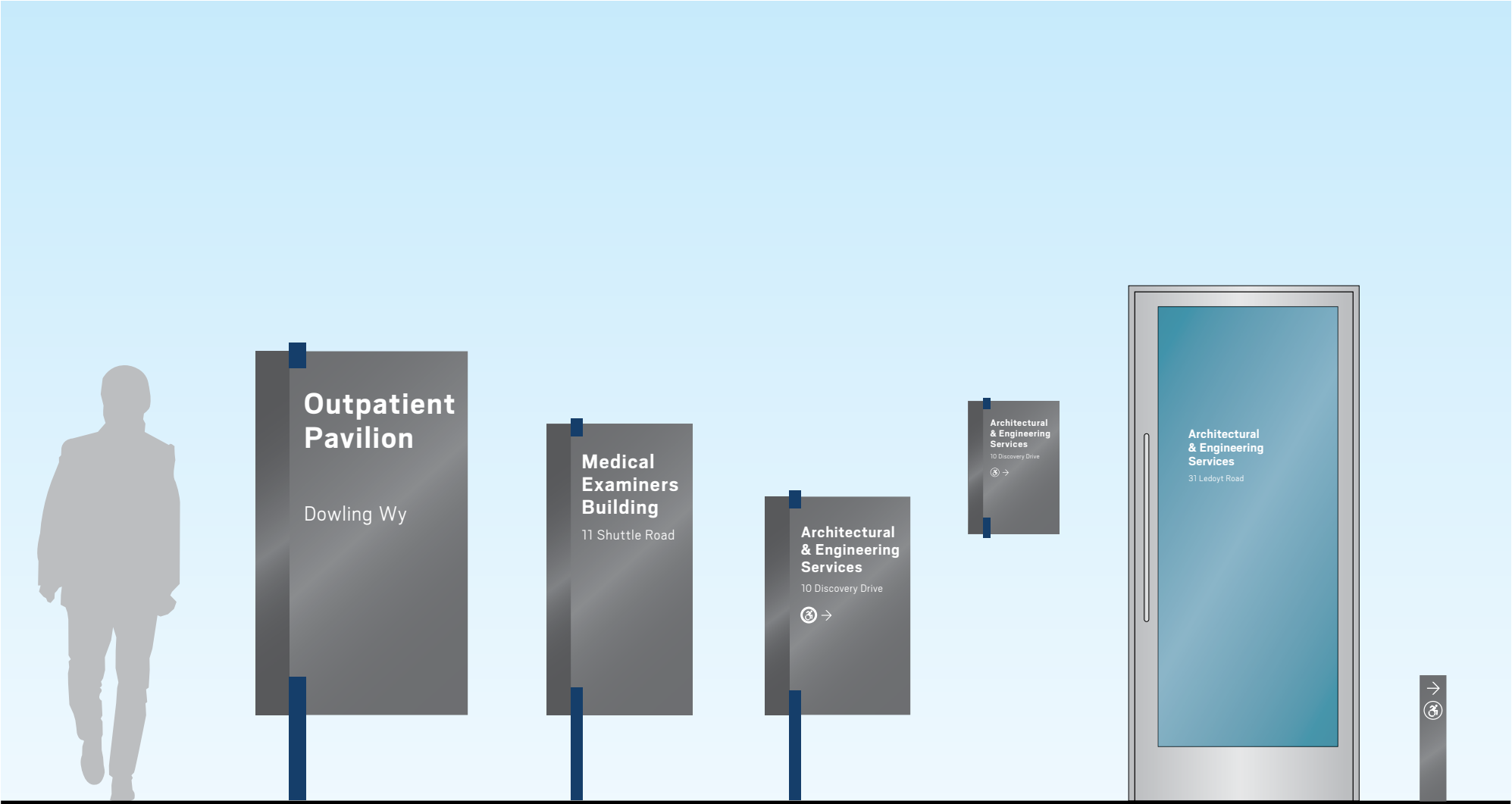

Sign Type J0
Primary Building ID,
Freestanding, Large

Sign Type J1
Primary Building ID,
Freestanding, Small

Sign Type J2
Secondary Building ID,
Freestanding

Sign Type J3
Secondary Building ID,
Wall Mounted

Sign Type J4
Secondary Building ID,
Door Mounted

Sign Type K
Accessible
Pathway Marker

Honorific Destination Messaging

A messaging strategy has been developed to address campus destinations with donor names. This strategy proposes abbreviating such building names composed of fewer words to encourage immediate recognition and quicker memorization, thus standardizing the overall name length on the most wayfinding signs.

The abbreviated building names shall be displayed on the directional wayfinding (sign type B and H series) and freestanding building identification signs (sign types J0, J1, and J2). Full building name, incorporating donor recognition in a modified typographic style, shall be displayed at the arrival point, on the wall-mounted Building Identification Sign (sign type J3 or J4), and on the Pedestrian Orientation Kiosk (sign type G).



1 Sign Type Building Identification
3/8" = 1'-0"

Regulatory Sign Types

These sign types provide operational/instruction information.

Sign Type P is typically programmed at parking facilities, and display information such as operating hours.

Sign Type Q1 & Q2 is typically programmed at athletic and recreational facilities and inform visitors and users of do and don't.

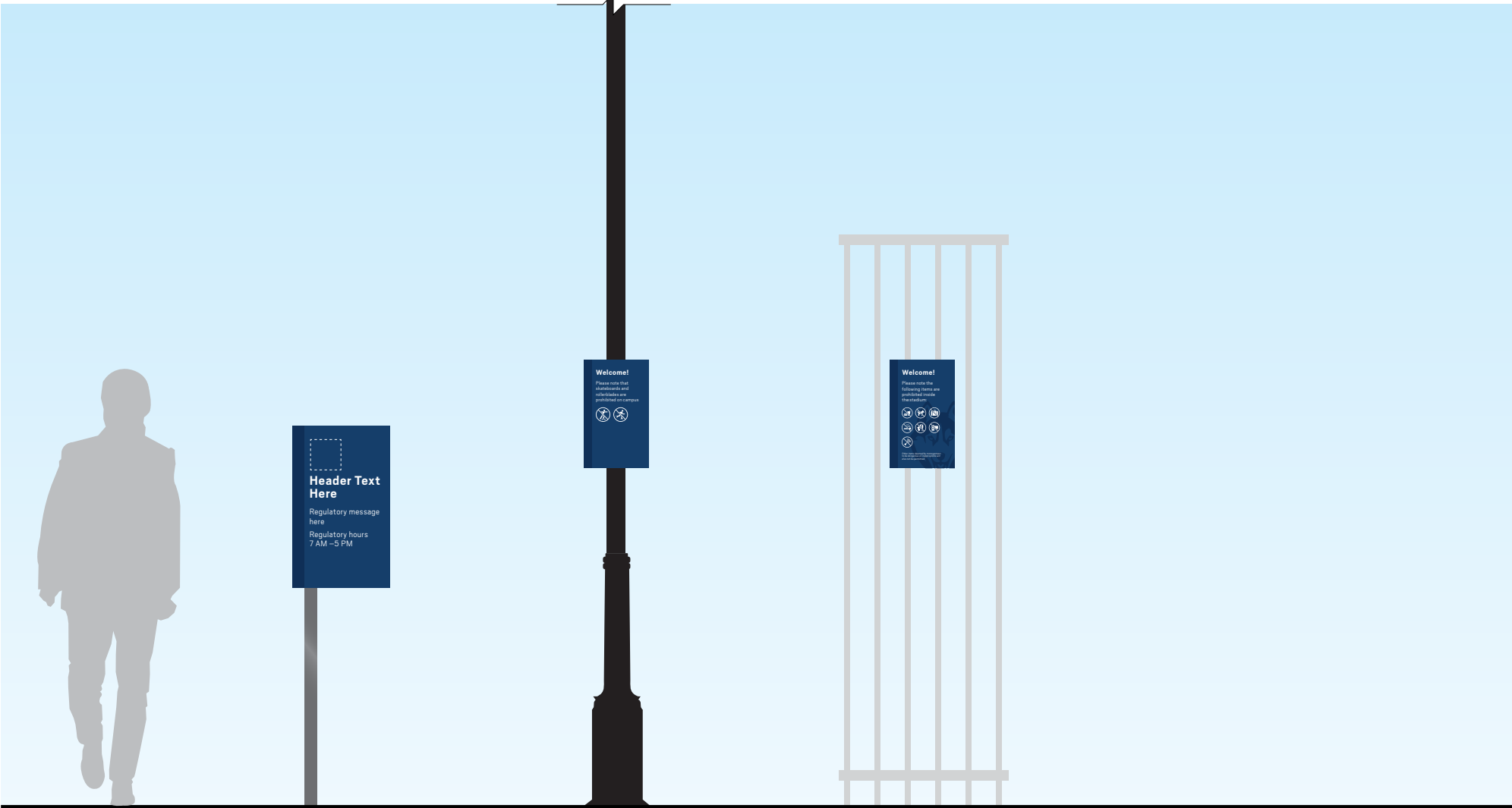

Sign Type P
Regulatory,
Vehicular

Sign Type Q1
Regulatory,
Pedestrian

Sign Type Q2
Regulatory,
Pedestrian, Fence Mounted

SIGN TYPE FAMILY OVERVIEW

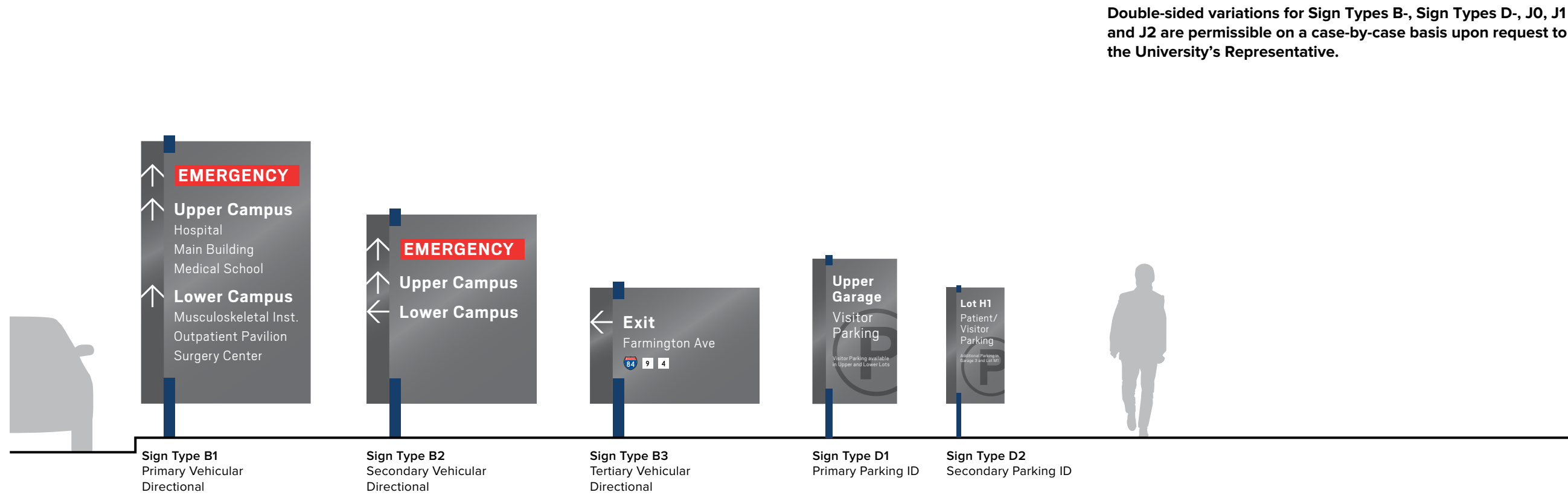

Double-sided variations for Sign Types B-, Sign Types D-, J0, J1 and J2 are permissible on a case-by-case basis upon request to the University's Representative.

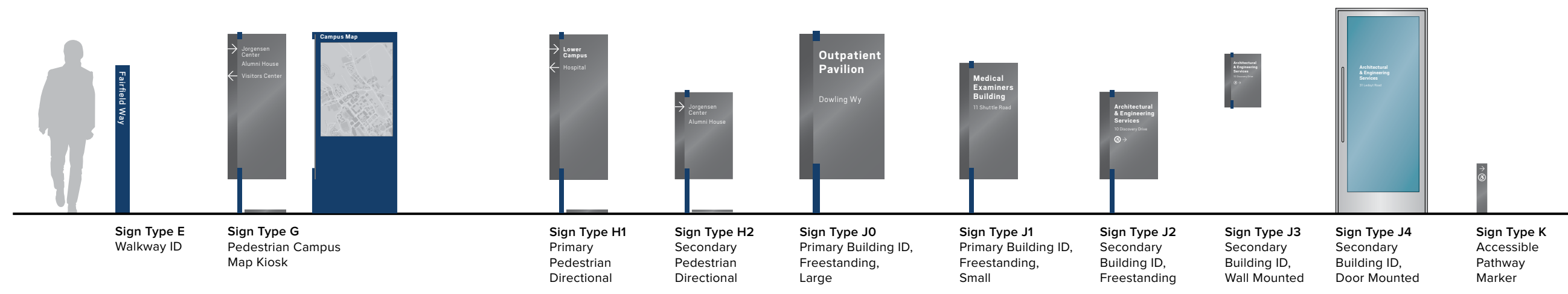

TWO TWELVE

902 BROADWAY
FLOOR 20
NEW YORK, NY
10010/6002
212 254/6670 T
212 254/6614 F

For Planning & Coordination Only –
Not for Construction

This document and the entirety of its contents are property of 212/Harakawa Inc. and/or Two Twelve Associates, Inc. No part of this document shall be duplicated, disseminated, distributed or used for any purpose without express written permission.

Do not use for final construction. Sign fabricator to verify and be responsible for all dimensions and work conditions and inform this office of variations prior to performing work. Written dimensions govern over scaled dimensions.

No. Revisions

21 Apr 2020 Revision 2

Date 15 May 2017

Project No. UCONN-046

Phase CID

Project Title
University of Connecticut
Campus Wayfinding

Drawing Title
**Sign Type Family
Overview**

Drawing No.
CID.02

SIGN TYPE FAMILY OVERVIEW

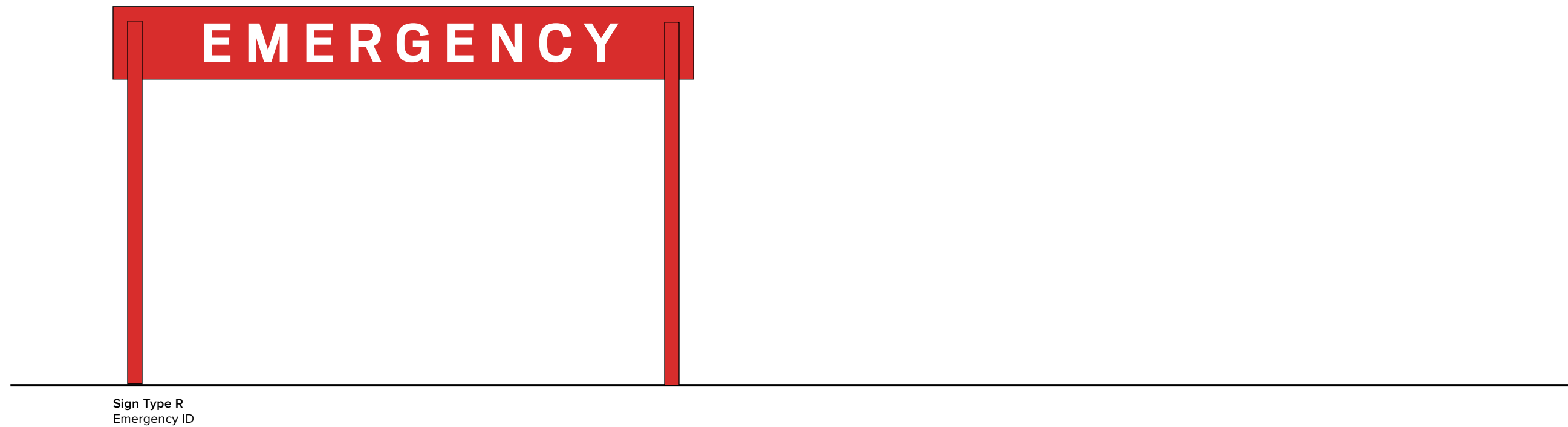
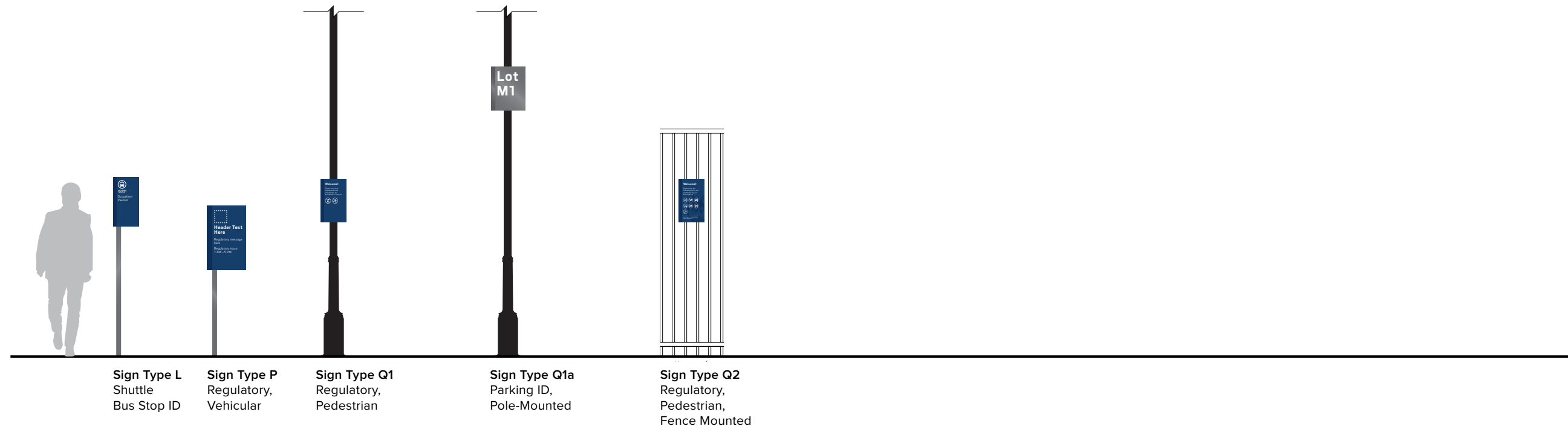

TWO TWELVE

902 BROADWAY
FLOOR 20
NEW YORK, NY
10010/6002
212 254/6670 T
212 254/6614 F

For Planning & Coordination Only –
Not for Construction

This document and the entirety of its contents are property of 212/Harakawa Inc. and/or Two Twelve Associates, Inc. No part of this document shall be duplicated, disseminated, distributed or used for any purpose without express written permission.

Do not use for final construction. Sign fabricator to verify and be responsible for all dimensions and work conditions and inform this office of variations prior to performing work. Written dimensions govern over scaled dimensions.

No.	Revisions
-----	-----------

Date 15 May 2017

Project No. UCONN-046

Phase CID

Project Title
University of Connecticut
Campus Wayfinding

Drawing Title
**Sign Type Family
Overview**

Drawing No.
CID.03

TYPOGRAPHY

Scout - Bold

ABCDEFGHIJKLMNOPQRSTUVWXYZ
abcdefghijklmnopqrstuvwxyz
0123456789 ,./-

Scout - Regular

ABCDEFGHIJKLMNOPQRSTUVWXYZ
abcdefghijklmnopqrstuvwxyz
0123456789 ,./-

Scout - Light

ABCDEFGHIJKLMNOPQRSTUVWXYZ
abcdefghijklmnopqrstuvwxyz
0123456789 ,./-

Scout - Light Italic

ABCDEFGHIJKLMNOPQRSTUVWXYZ
abcdefghijklmnopqrstuvwxyz
0123456789 ,./-

Typographic Requirements

CODE	TYPEFACE / SPECIFICATION	KERNING	SIGN TYPES
T1	Scout (Bold) Text - Upper Case	+200	R
	Scout (Bold) Text - Upper Case	+60	B1, B2, B3
	Scout (Bold) Text - Title Case	+45	B1, B2, B3, D1, D2, G, H1, J0, J1, J2, Q1a
	Scout (Bold) Text - Title Case	+30	J3, J4, P, Q1, Q2
T2	Scout (Regular) Text - Title Case	+45	E, H1, H2
T3	Scout (Light) Text - Title Case	+30	B1, B2, B3, D1, D2, G, H1, H2, J0, J1, J2
	Scout (Light) Text - Title Case	+15	D1, D2, J3, J4, L, P, Q1, Q2
T4	Scout (Light Italic) Text - Title Case	+15	Q2
T5	Scout (Light Italic) Text - Upper Case	+30	J3

GENERAL NOTE

Kerning/letter spacing of all typography is to match the examples in the Construction Intent Documents which were prepared in Adobe Illustrator CS6, Version 16.0.4, with "optical" kerning and the noted numeric value(s) in the kerning/letter spacing option(s). Sign Contractor shall compare their resulting kerning/letter spacing with the examples provided and adjust accordingly.

Sign Contractor and/or other users are responsible for purchasing specified typefaces.

TWO TWELVE

902 BROADWAY
FLOOR 20
NEW YORK, NY
10010/6002
212 254/6670 T
212 254/6614 F

For Planning & Coordination Only –
Not for Construction

This document and the entirety of its contents are property of 212/Harakawa Inc. and/or Two Twelve Associates, Inc. No part of this document shall be duplicated, disseminated, distributed or used for any purpose without express written permission.

Do not use for final construction. Sign fabricator to verify and be responsible for all dimensions and work conditions and inform this office of variations prior to performing work. Written dimensions govern over scaled dimensions.

No.	Revisions
-----	-----------

Date	15 May 2017
------	-------------

Project No.	UCONN-046
-------------	-----------

Phase	CID
-------	-----

Project Title	
---------------	--

University of Connecticut Campus Wayfinding	
--	--

Drawing Title	
---------------	--

Typography	
-------------------	--

Drawing No.	
-------------	--

CID.04	
---------------	--

SYMBOLS

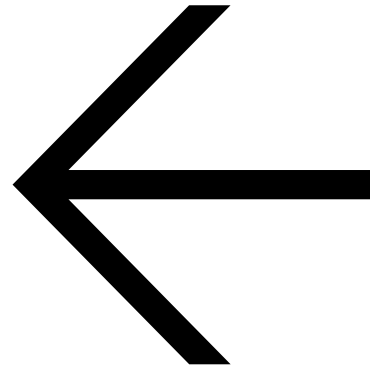

Arrow Left

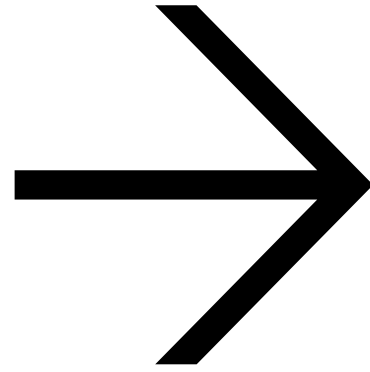

Arrow Right

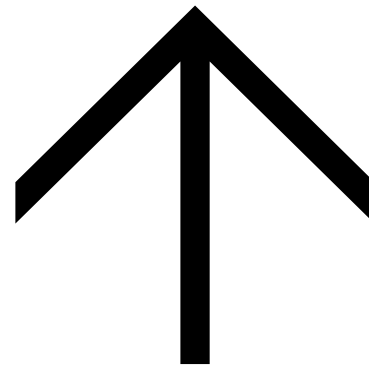

Arrow Up



Parking



UConn Husky

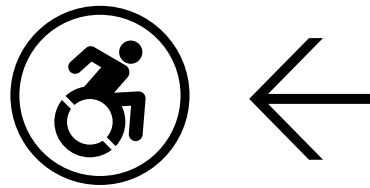

Building ID -
Accessible Arrow Left

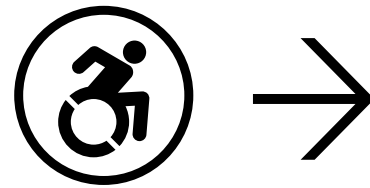

Building ID -
Accessible Arrow Right

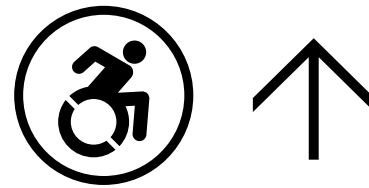

Building ID -
Accessible Arrow Up



**UCONN
HEALTH**

UConn Health Shuttle

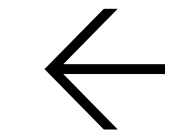

Pathway -
Accessible Arrow Left

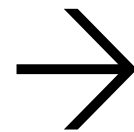

Pathway -
Accessible Arrow Right



Pathway -
Accessible Arrow Up

TWO TWELVE

902 BROADWAY
FLOOR 20
NEW YORK, NY
10010/6002
212 254/6670 T
212 254/6614 F

For Planning & Coordination Only –
Not for Construction

This document and the entirety of its
contents are property of 212/Harakawa
Inc. and/or Two Twelve Associates, Inc.
No part of this document shall be
duplicated, disseminated, distributed
or used for any purpose without
express written permission.

Do not use for final construction. Sign
fabricator to verify and be responsible
for all dimensions and work conditions
and inform this office of variations prior
to performing work. Written dimensions
govern over scaled dimensions.

No.	Revisions

Date 15 May 2017

Project No. UCONN-046

Phase CID

Project Title

University of Connecticut
Campus Wayfinding

Symbols

CID.05

SYMBOLS



I-84

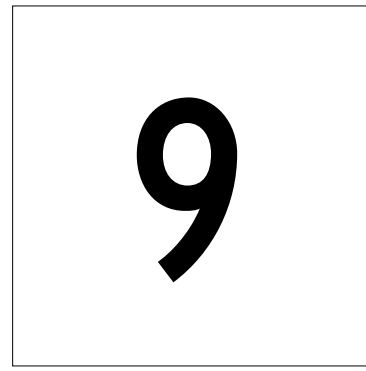

Route 9

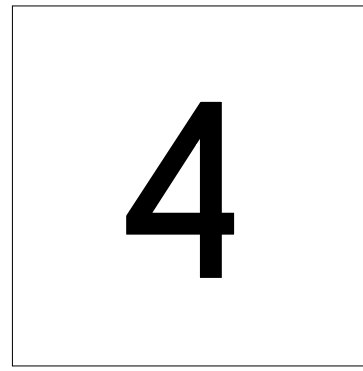

Route 4



No Skateboarding



No Rollerblading



No Outside Food

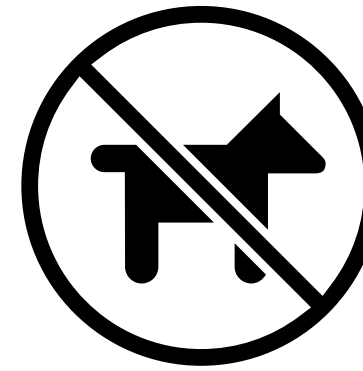

No Pets



No Bags



No Smoking



No Weapons



No Video Cameras



No Noisemakers

TWO TWELVE

902 BROADWAY
FLOOR 20
NEW YORK, NY
10010/6002
212 254/6670 T
212 254/6614 F

For Planning & Coordination Only –
Not for Construction

This document and the entirety of its
contents are property of 212/Harakawa
Inc. and/or Two Twelve Associates, Inc.
No part of this document shall be
duplicated, disseminated, distributed
or used for any purpose without
express written permission.

Do not use for final construction. Sign
fabricator to verify and be responsible
for all dimensions and work conditions
and inform this office of variations prior
to performing work. Written dimensions
govern over scaled dimensions.

No.	Revisions
-----	-----------

Date 15 May 2017

Project No. UCONN-046

Phase CID

Project Title
University of Connecticut
Campus Wayfinding

Symbols

CID.06

FINISH SCHEDULE

Finish Schedule

CODE	COLOR	PAINT TO MATCH	REFERENCE
F1		Akzo Nobel 357C3, Satin Finish	Light Gray <i>Message Panel, Regulatory Post</i>
F2		Akzo Nobel 626B1, Satin Finish	Dark Gray <i>Message Panel Border</i>
F3		Akzo Nobel 479E4, Satin Finish	Blue <i>Bracket, Regulatory Message Panel, Roadway ID</i>
F4		Akzo Nobel 480E5, Satin Finish	Dark Blue <i>Regulatory Panel Border</i>
F5		Akzo Nobel White, Satin Finish	White <i>Pedestrian Sign Text</i>
F6		3M Reflective Graphic Film 5100-100	White <i>Vehicular Sign Text</i>
F7		3M Reflective Graphic Film 5100-72	Red <i>Emergency Graphic, Interstate Symbol</i>
F8		3M Reflective Graphic Film 5100-85	Black <i>Route Symbol</i>
F9		Pantone 287	Light Blue <i>Interstate Symbol</i>
F10		3M Scotchcal™ Translucent Graphic Film White 3630-20	White <i>Building ID, Door Mounted</i>
F11		Pantone 485	Red <i>Emergency Sign Structure</i>

TWO TWELVE

902 BROADWAY
FLOOR 20
NEW YORK, NY
10010/6002
212 254/6670 T
212 254/6614 F

For Planning & Coordination Only –
Not for Construction

This document and the entirety of its contents are property of 212/Harakawa Inc. and/or Two Twelve Associates, Inc. No part of this document shall be duplicated, disseminated, distributed or used for any purpose without express written permission.

Do not use for final construction. Sign fabricator to verify and be responsible for all dimensions and work conditions and inform this office of variations prior to performing work. Written dimensions govern over scaled dimensions.

No.	Revisions

Date 15 May 2017

Project No. UCONN-046

Phase CID

Project Title

University of Connecticut
Campus Wayfinding

Finish Schedule

CID.07

Construction Intent Documents

- 3.01 Technical Specifications
- CID.08 Primary Vehicular Directional (B1)
- CID.15 Secondary Vehicular Directional (B2)
- CID.22 Tertiary Vehicular Directional (B3)
- CID.28 Primary Parking ID (D1)
- CID.34 Secondary Parking ID (D2)
- CID.40 Walkway ID (E)
- CID.43 Pedestrian Campus Map Kiosk (G)
- CID.50 Primary Pedestrian Directional (H1)
- CID.57 Secondary Pedestrian Directional (H2)
- CID.64 Primary Building ID, Freestanding, Large (J0)
- CID.71 Primary Building ID, Freestanding, Small (J1)
- CID.77 Secondary Building ID, Freestanding (J2)
- CID.83 Secondary Building ID, Wall-Mounted (J3)
- CID.87 Secondary Building ID, Door-Mounted (J4)
- CID.89 Accessible Pathway Marker (K)
- CID.91 Shuttle Bus Stop ID (L)
- CID.94 Regulatory, Vehicular (P)
- CID.97 Regulatory, Pedestrian (Q1)
- CID.101 Parking ID, Pole-Mounted (Q1a)
- CID.104 Regulatory, Pedestrian, Fence-Mounted (Q2)
- CID.108 Emergency ID (R)

SECTION 10400 SIGNAGE

PART 1 GENERAL

The drawings which comprise part of these contract documents are intended to show design intent only. Details are included only as suggestions to the Contractor as to how signs and components may be fabricated and installed. These Specifications are intended as a guide for minimum standards only. It is the Contractor's responsibility to engineer and design all details so that all signs, mountings, anchorages, and other components are structurally sound, stable and safe for use, are of sufficient durability to withstand the rigors of the locations in which they are to be installed. If any of the details, processes, materials, or finishes specified in the drawings or specifications are insufficient to fulfill these requirements the Contractor shall substitute details, processes, materials, or finishes of sufficient functionality, strength and durability. All changes from the design intent drawings and specifications shall be indicated in shop drawings, which shall be submitted for the Owner's approval prior to manufacture. Approval of shop drawings shall not absolve the Contractor from any of the responsibilities referred to above and any such approval shall be conditional on the Contractor's guarantee that the above requirements have been met. The Contractor shall take full responsibility for, and shall indemnify and hold harmless the Designer against, any claim resulting from failure of, or damage caused by, the installed signs.

In the event of any conflict between the following conditions and any other document(s) issued by the Owner, Architect or Interior Designer and forming part of this contract, the requirements of the latter document(s) shall take precedence and apply.

1.1 GENERAL REQUIREMENTS

- A. Work of this Section, as shown or specified, shall be in accordance with the requirements of the Contract Documents.

1.2 DEFINITIONS

- A. For the purpose of this document the following definitions shall apply:
 1. Owner shall mean University of Connecticut, as represented by [entity name], [mailing address].
 2. Design Consultant shall mean Two Twelve, 902 Broadway, Floor 20, New York, NY 10010.
 3. Sign Contractor shall mean the individual, firm or corporation executing the contract and performing the work under the terms of these Contract Documents.
 4. General Contractor shall mean the individual, firm or corporation responsible for the site and renovation work on and within which the work which forms the subject of this contract is to be installed.

5. Contract Documents shall mean all drawings, schedules, specifications and other items comprising the contract.
6. Date of Substantial Completion shall mean the date upon which the work which is the subject of this contract is sufficiently complete to enable the Owner to use it for the purpose and in the manner in which it was intended.
7. Sign shall mean any sign or graphic work to be installed on the site or applied to an architectural component, or other element described or specified in the Contract Documents.
8. Graphic Components shall mean all typography, illustrations, line drawings, maps, charts, etc. forming part of a sign.
9. Artwork shall mean scalable electronic vector artwork in Adobe Illustrator or Adobe InDesign format for any specific graphic component of individual signs, symbols, logotypes, line drawings, to be used in the production of signs by the Sign Contractor.
10. Graphic Layouts shall mean production ready artwork drawn to an architectural scale demonstrating all Graphic Components and colors of an individual sign type.
11. Character shall mean any visual element of a sign, including letters, numerals, punctuation marks, symbols, etc.
12. Color fill shall mean any paint, ink, dye, varnish or other material used to fill engraved, etched, or incised characters.
13. Paint shall mean any paint, ink, dye, varnish or other coating material.
14. Adhesive shall mean any liquid, aerosol, sheet, tape or foam tape adhesive or solvent bonding system.

1.3 SCOPE OF WORK

- A. Work of this Section includes all labor, materials, equipment and services necessary to complete the signage as shown on the drawings and/or specified herein, but not limited to the following:
 1. Painted and fabricated aluminum box construction sign forms with concrete foundations
 2. Painted and fabricated aluminum box construction sign forms with internal illumination, and concrete foundations
 3. Painted aluminum panels with silkscreen letters and graphics

4. Painted and fabricated sign posts and brackets
5. Die-cut reflective vinyl letters and graphics
6. Die-cut painted vinyl letters and graphics
7. Full-color digital prints on adhesive film

- B. The Contractor shall fabricate and install signs as indicated in the attached Design Intent Drawings, Sign Locations Plans, and Sign Message Schedules and as specified herein.

1.4 QUALITY ASSURANCE AND PERFORMANCE REQUIREMENTS

- A. Delegated Design Requirements:
 1. All constructional, engineering and anchoring details indicated on the Design Consultant's drawings are for design intent only. The Sign Contractor shall take full responsibility for the correct and safe engineering of all sign types and the way in which they are supported and anchored without compromising the design intent. The internal structure, dimensions and specifications for all item shall be indicated on the Sign Contractor's shop drawings and shall indicate any alternative details which are necessary to result in a satisfactory and safe final product. The Sign Contractor shall indemnify and hold harmless the Design Consultant against any claim resulting from failure of, or damage caused by, the installed signs.
 - a. A Connecticut state-licensed Professional Engineer shall sign and seal the submittal of shop drawings.
- B. The approved Sign Contractor shall have at least seven (7) years of experience in the type of work required, shall have a reputation for doing satisfactory work on time; and shall have recently successfully completed similar work. See Section 1.5 for further requirements.
- C. Comply with all current codes and requirements of all relevant local and state regulatory agencies, as referenced below. Where so required, tests shall be made and certificates of conformance shall be secured at the expense of the Sign Contractor.
 1. ANSI: American National Standards Institute
 2. ASTM: American Society for Testing and Materials, 1916 Race Street, Philadelphia, PA 19103 as published in "Compilation of ASTM Standards in Building Codes".
 3. ADAAG: Americans with Disabilities Act Accessibility Guidelines, 2010 ADA Standards for Accessible Design

4. MUTCD: Manual on Uniform Traffic Control Devices
 5. ConnDOT: Connecticut Department of Transportation
- D. Structural Performance: Provide signs capable of withstanding the effects of gravity loads and the following loads and stresses within limits and under conditions indicated, determined according to ASCE 7, "Minimum Design Loads for Buildings and Other Structures":
1. Wind Loads: Determine loads based on a uniform pressure of 100 mph acting in any direction.
- E. All artwork and templates created by the Sign Contractor for the production of the work under this contract shall be the property of the Owner, and shall be delivered to the Owner upon request.
- F. Warranty: See Section 1.13 Below.

1.5 SIGN CONTRACTOR QUALIFICATIONS

- A. Sign Contractor shall provide references of at least five (5) clients who have used their services to the satisfaction of the Owner and Design Consultant.
- B. Sign Contractor shall provide evidence of successfully completing manufacture and installation of three (3) projects of similar scope to this bid within the preceding three (3) years.
- C. Sign Contractor must be able to demonstrate that they are in compliance with all workers safety and environmental regulations at their location of manufacture.
- D. Sign Contractor must be able to fabricate in-house at least 70% of the components required to produce this Scope of Work.
- E. Sign Contractor shall post bond equal to the value of the items listed in Sign Program bid documents for the life of the contract. [NOTE to OWNER: edit as needed, Delete if not required]

1.6 SUB CONTRACTORS

- A. Sign Contractor responsible for coordinating, managing, and quality control for all activities of subcontractors. Any on-site work conducted by subcontractors to be supervised by Sign Contractor.
- B. The Bidder shall submit with the price quotation the name of any subcontractor(s) who will be doing any work on this project.
- C. Minority Ownership: Submit evidence of minority ownership and/or identify minority-owned firms that have been successfully utilized on similar projects as a direct sub-contractor within the preceding five (5) years. Project examples are to include a breakdown of the level of minority-owned direct subcontractor inclusion that has been achieved in each project and the type of work performed by each minority subcontractor. [NOTE to OWNER: edit as needed, Delete if not required]

1.7 BID SUBMISSIONS

- A. Bids must reflect the entire Scope of Work outlined in the enclosed documents and are to be itemized as line item costs for the fabrication/ installation of individual signs by sign type. Additionally, general conditions, submissions, bonds, taxes, and other miscellaneous costs should be itemized as separate line item costs in the bid response.
- B. All bids shall be submitted on the Standard Bid Form provided. Any bids not submitted on the Bid Form may be disqualified. Sign Contractor shall verify all quantities in the Sign Schedule and Bid Form.
- C. Bids are to be submitted no later than the date indicated in order to be considered for this project. Any delays to the submission of these items may disqualify bidder from the bid review process, at Owners discretion.
- D. Sign Contractor shall submit one (1) partial sample prototype of Sign Type XX as defined in the Contract Documents, dated [NOTE to OWNER: insert date], with the bid. This prototype is to be made without any assistance from the project team. This submittal will be used as an indication of the bidder's ability to read the design drawings, follow the specifications, and shall represent the quality control capabilities of the company. This prototype will be used in conjunction with the Sign Contractor's bid to identify the best-qualified bidder for the project.
- E. Extent of Sign Program requirements are shown on, and shall be in accordance with, the Design Intent Drawings and related materials (Contract Documents) submitted by the Design Consultant. These include all labor, materials, equipment and services necessary to complete the signage as outlined within those documents.
- F. If there is a conflict, stated dimensions on the Drawings shall take precedence over scaled dimensions. Should a Bidder find discrepancies in, or omissions from, the contract documents, or be in doubt as to their meaning he shall notify the Design Consultant at once. If it should be found necessary, a written addendum will be sent to each Bidder. Neither the Owner nor the Design Consultant will be responsible for oral instructions.
- G. Sign Contractor shall be responsible for ensuring that there are no pricing or tabulation errors in submitted bids and shall not make any claims for extra payment as a consequence of any such errors.
- H. It shall be assumed that the Sign Contractor has inspected the site prior to submitting a bid, and is aware of all site and operational conditions affecting the fabrication and installation of the work. No extra charges shall be claimed or allowed due to a failure of the Sign Contractor from making such inspections.
- I. Sign Contractor to furnish a schedule indicating the number of weeks required from signing of a Contract to the commencement of installation, and the number of weeks required for completing the installation process. If necessary, separate information can be given for different groups of signs.

- J. All signs listed in the Scope of Work shall be installed by union installers. [NOTE to OWNER: edit as needed, Delete if not required]

1.8 SUBMITTALS

- A. All submittals shall occur in the sequence outlined below. Submittals that are out of sequence may be rejected or held for approval pending prerequisite submittals.
- B. Unless otherwise noted, two (2) sets hard copy of all submittals for approval prior to fabrication or installation, as follows:
 - One (1) set to Owner
 - One (1) set to Project Manager/Construction Manager
 [NOTE to OWNER: edit as needed, Delete if not required]
- C. Schedule
 1. Submit a detailed production and installation schedule for all sign types including dates for submission and approval of all required samples, shop drawings and other submissions required under this contract.
 2. This schedule shall identify 'drop dead' receipt dates of final message schedule and artwork from Design Consultant / Owner in order that the overall schedule is maintained.
 3. Allow (10) ten days for Design Consultant / Owner review of submittals. Schedule to allow for adequate review and possible re-submittals without jeopardizing the project schedule.
- D. Shop Drawings
 1. Submit shop drawings showing proposed details of fabrication and installation of all components. Include plans, elevations, enlarged details, vertical and horizontal section details, etc. to the degree required to demonstrate full fabrication and installation means and methods. Details not shown are to be at least equal in quality to those detailed.
 2. Drawings to be printed at an architectural scale sufficient to read all details. Include large-scale details of construction, anchorages and accessory items.
 - a. Installation elevation to be a minimum of 1/2" = 1'-0"
 - b. Sign Elevations to be a minimum of 3/4" = 1'-0"
 - c. Section details of small sign types to be a minimum of 6" = 1'-0"
 - d. Section details of large sign types to be a minimum 3"=1'-0"
 3. Connections, angles, shapes and details shown in Design Intent Drawings are suggestive. Sign Contractor is responsible for proper engineering of all sign components.

4. All components are to be sized, reinforced and detailed as required for their particular application and location. All connections into existing surfaces are to be field verified and / or fully coordinated with architectural conditions prior to submitting sign shops drawings.
 - a. Where sizes of signs may be affected by dimensions of surfaces on which they are installed, verify dimensions by field measurement. Show recorded measurements on shop drawings.
5. Shop Drawings should demonstrate coordination with field verified conditions.
 - a. For all ground mounted signage, inspect and evaluate grade conditions to ensure leveled surface for signage placement.
6. Confer with the Design Consultant regarding any critical items, and advise the Design Consultant of any significant discrepancies in field measurements or operational difficulties.
7. All variations from the Contract Documents shall be shown on the shop drawings and shall be specifically identified as such by the Contractor. All proposed variations shall equal or surpass the requirements of the originally specified items with regard to appearance, finish, material qualities, size, etc.
8. Sign Contractor shall provide a licensed engineer's details to provide suitable materials, gauges, footings, anchors, materials compatibility, structural integrity, etc., as required for proper and secure mounting or installation and in accordance with all local sign codes. Show all anchorages and accessory items.

E. Graphic Layouts

1. Submit full-size hard copy laser prints of fabrication-ready artwork of **each unique sign location** showing all components and messages. Label each layout with its location number. Indicate all color breaks. Submittal will be reviewed by the Design Consultant for letter, word, and line spacing, as well as, overall size, sharpness, alignment, accuracy of letterform, and copy composition.
2. Layouts that do not fit full-size on 11"x17" paper may be submitted at half- or one quarter-full size only. All submittals must be able to be read with an architectural scale.
3. Typesetting shall have proper letter, word and line spacing as specified in the Design Documents. Characters shall be sharp, accurately aligned on their baseline, and of consistent density.
4. Copy shown on any drawings and templates is intended as a guideline for layout and type size only. Refer to the Message Schedule for exact wording for each layout.

F. Material and Finish Samples

1. Two (2) sets of 4" x 4" samples for each type of material, color, and finish combination specified.
 - a. Paint and Coatings: For each color specified, submit 1/8" thick substrate with paint and clear coat finish. Paint color match to be shop applied, manufacturer's lab samples are not acceptable.
 - b. Silkscreen Inks: For each graphic and background combination specified, submit 1/8" thick substrate with painted background, silkscreen text, and clear coat finish.
 - c. Vinyl Sheet: For each color, submit 6" x 6" swatches
 2. Color match samples to be prepared on actual sign material substrates and employing all actual processes specified in Contract Documents. Clearly indicate on the back the color specification, date, and submittal number.
 3. Design Consultant's review of samples will be for color and texture only. Compliance with all other requirements is the exclusive responsibility of the Sign Contractor. One (1) set of samples will be kept by the Design Consultant as a record to match against completed installation and for future reference.
- G. Full Workmanship Prototypes
1. One (1) complete or partial prototype sample as noted in the Prototype Schedule below shall be fabricated for review, testing and approval by Owner/Design Consultant, prior to manufacture of any of the final signs of any type for installation.
 2. Prior to fabrication of partial prototypes, Sign Contractor to submit clarification drawings to Design Consultant for review and approval, detailing all elements to be included in each unique partial section prototype. Prototypes to clearly demonstrate all materials, finishes, fasteners, structure, mounting methods, detailing, etc. that are part of the complete sign type.
 3. All Prototypes to be prepared pending final approval of shop drawings, graphic layouts, and samples noted above.
 4. Prototypes are representative parts of the full sign scope. Design Consultant reserves the right to adjust final details, sizes, colors, materials and finishes to be incorporated in the production of the any final sign types based upon results of prototyping.
 5. After inspection and approval all samples must be delivered to the Design Consultant and will become his property as a record to match against completed installation. In no event shall any samples, whether approved or not, be permanently installed as part of the finished work.
 6. Prototype Schedule
 - a. Full Prototypes
 - 1). Sign Type J3

- 2). Sign Type J4 on clear acrylic panel
 - 3). Sign Type Q1 on mock sign post (painted aluminum tube)
 - 4). Sign Type Q2
- b. Partial Prototypes
- 1). Sign Type B3 3'-0" W x full sign panel height x full sign depth Section to fully demonstrate construction of sign panels, posts, reveals, materials, paint finishes, application of graphics. Graphics to include "Emergency" band, "Exit", "Interstate 84" symbol.
 - 2). Sign Type D2 Full sign panel with 6" post Section to fully demonstrate construction of pylon faces, reveals, materials, paint finishes, application of graphics.
 - 3). Sign Type G2'-0" W x 2'-0" H x full sign depth Section to fully demonstrate construction of the two (2) intersecting sign panels, posts, reveals, materials, paint finishes, application of graphics. Graphics to include Directional Messages and Maps.
 - 4). Sign Type L Full sign panel with 6" post Section to fully demonstrate construction of pylon faces, reveals, materials, paint finishes, application of graphics.

1.9 DELIVERY STORAGE AND HANDLING

- A. Clearly label the contents of all packages.
- B. Deliver, store and handle all packages so as to protect them from any kind of damage. Inspect all components for evidence of damage at site before installation. Damaged materials shall not be incorporated into the work and shall be removed from the site immediately.
- C. The Contractor shall replace at his own expense all work judged damaged or defective before Substantial Completion.

1.10 RESTORATION

- A. Protect all adjacent surfaces during on-site work and installation of signage. Restore any damage caused back to the original condition to the satisfaction of the Owner.
- B. See Section 3.5 CLEANING AND PROTECTION for additional requirements.

1.11 MAINTENANCE MANUAL

- A. Before Substantial Completion, provide the Owner with one (1) copy of clearly written instructions for proper maintenance of all work including any electrical systems. Instructions shall address periodic cleaning,

service access, painting, color specifications, re-lamping, replacement procedures, etc. Provide detailed troubleshooting and “what to check” lists for all customized electrical or mechanical systems.

- B. Extra Materials: Deliver to the Owner or facility’s management, in manufacturer’s original packaging, and store at the project site where directed.
 - 1. Furnish one (1) quart of each paint and finish color for touch-up purposes
 - 2. Furnish five (5) painted sign blanks for removable portion of Sign Type A1, including screw holes and spare hardware.

1.12 FUTURE PRICING GUARANTEES

- A. Furnish cost information for future purchases, guaranteed for two (2) years from the date of completion of this Contract, for all sign types listed in the pricing schedule. Information shall include costs for items ordered individually as well as minimum order requirements in order to obtain price breaks.

1.13 ATTIC STOCK

- A. At the time of Bid Award, Architect/Owner may request Sign Contractor to furnish extra fully fabricated sign pieces that match products installed and that are packaged with protective covering for storage and identified with labels describing contents, as follows: [NOTE to OWNER: edit as needed, Delete if not required]
 - 1. Sign Type Q1: Furnish five (5) extra sign panels with “Forbidden Access Beyond This Point” message.
 - 2. Sign Type Q3: Furnish ten (10) extra sign panels with “Staff Only” message.
- B. If requested by the Owner, contractor may provide storage space for attic stock. The cost of this will be a negotiated fee between the owner and the contractor on a per square footage basis.

1.14 WARRANTY

- A. General: The following warranty shall not deprive the Owner of other rights the Owner may have under other provisions of the contract Documents and shall be in addition to, and run concurrent with, other warranties made by the Contractor under requirements of the Contract Documents.
- B. Sign Warranty: Submit five-year (5) written warranty, signed by the Sign Contractor and Installer, warranting that the architectural signage and/or finishes will not develop excessive fading or excessive non-uniformity of color or shade and will not crack, peel, pit or corrode or

otherwise fail as a result of defects, within the warranty period, make necessary repairs or replacement at the convenience of the Owner or facility’s management. Failures include, but are not limited to, the following:

- 1. “Excessive Fading”: A change in appearance which is perceptible and objectionable as determined by the Design Consultant when visually compared with the original color range standards.
 - 2. “Excessive Non-Uniformity”: Non-Uniform fading during the period of the guarantee, to the extent that adjacent panels have a color difference greater than the original acceptance range of color.
 - 3. “Will Not Pit or Otherwise Corrode”: No Pitting or other type of corrosion discernible from a distance of 10’-0”, resulting from the natural elements in the atmosphere at the project site.
 - 4. Coating degradation
 - 5. Chalking
 - 6. Structural failure
 - 7. Delamination of applied graphics
 - 8. Delamination or degradation of applied anti-graffiti coatings
- C. Defects or faulty materials found during the warranty period will be identified to Sign Contractor by Owner. Such defective materials are to be repaired and/or replaced at Sign Contractor’s own expense, together with any damage to furnishings, fixtures, finishes, or other equipment that may be damaged as a result of these effects.
 - D. If Sign Contractor shall fail to repair, replace, rebuild, or restore defective or damaged work promptly after receiving notice, Owner shall have the right to have the work completed by others in the same manner as provided for in the completion of a defaulted contract, and to deduct the cost thereof from the amount so deposited hereunder. The balance, if any, shall be returned to Sign Contractor without interest. If the amount so deposited is insufficient to cover the cost of such work, Sign Contractor shall be liable to pay such deficiency on demand by Owner.
 - E. Owner certificate setting forth the fair and reasonable cost of repairing, replacing, rebuilding, or restoring any damaged or defective work when performed by one other than Sign Contractor and this cost shall be binding and conclusive as to the amount thereof upon Sign Contractor.

PART 2 - PRODUCT

2.1 MATERIALS

- A. General
 - 1. Provide the highest quality materials, carefully fabricated in accordance with Construction Intent Drawings, manufactured from new materials.
 - 2. Ensure that materials used are inert and that galvanic reactions do not occur between materials used, and between Sign materials and Architectural mounting surfaces.
 - 3. Where dissimilar metals are in contact, separate metals using a dielectric separator such as neoprene gaskets, nylon sleeves, or bituminous coatings to prevent galvanic action.
- B. Aluminum
 - 1. Aluminum extrusions shall be of alloy and temper recommended by aluminum producer for type of use and finish and with not less than strength and durability properties specified in ASTM B221 for 6063-T5.
 - 2. Aluminum sheet shall be of 6061-T6, 5005, or 5052-H38 alloys and temper as recommended by aluminum producer or finisher for use type and finish indicated, and with not less than strength and durability properties specified in ASTM B209 for 5005-H15. Sheet and plate shall be shop primed and of best architectural quality; stretcher leveled and visually flat.
 - 3. Aluminum Castings: ASTM B 26, of alloy and temper recommended by aluminum producer and finisher for casting process used and for use and finish indicated.
 - 4. Fabrication
 - a. Aluminum sheet signs shall be fabricated of sheet of sufficient thickness, and with any necessary internal reinforcement, to provide a sign surface which is stable and flat, and is free from ‘oil canning’ or other ripples or imperfections.
 - b. Aluminum shall be of best commercial quality and their various forms shall be straight and true. There shall be no scratches, scars, creases or buckles.
 - c. Where aluminum is shop fabricated, all joints, returns and the like shall be properly joined together and welded edges shall be ground smooth to proper aluminum finish.
 - d. Aluminum in contact with dissimilar metals shall have bituminous or other protective coating to prevent electrolytic action.
 - 5. Finishes

- a. Comply with NAAMM's "Metal Finishes Manual for Architectural and Metal Products" for recommendations for applying and designating finishes. Finish designations prefixed by AA comply with the system established by the Aluminum Association for designating aluminum finishes.
 - b. Baked-Enamel Finish: AA-C12C42R1x (Chemical Finish: cleaned with inhibited chemicals; Chemical Finish: acid-chromate-fluoride-phosphate conversion coating; Organic Coating: as specified below). Apply baked enamel complying with paint manufacturer's written instructions for cleaning, conversion coating, and painting.
 - c. Organic Coating: Thermosetting, modified-acrylic enamel primer/topcoat system complying with AAMA 2603 except with a minimum dry film thickness of 1.5 mils, medium gloss.
 - d. Color: As indicated on Contract Documents.
6. Aluminum Posts
- a. Fabricate posts to lengths required for mounting method indicated from manufacturer's standard 0.125-inch-thick, extruded-aluminum tubing. Provide stop blocks in slots to hold panels in position. Include post caps, fillers, spacers, access panels, and related accessories required for complete installation.
 - 1). Smooth Shaft Square Tube: 2 1/2-inch diameter posts as indicated on drawing
 - b. Baseplate Method: Provide posts with baseplates, flanges, or other fittings, welded to bottom of posts. Drill holes in baseplate for anchor-bolt connection.
 - c. Provide anchor bolts of size required for connecting posts to concrete foundations.

C. Structural Steel

- 1. Steel Sheet: Uncoated, cold-rolled, ASTM A 1008, commercial steel, Type B, exposed or electrolytic zinc-coated, ASTM A 591, with steel sheet substrate complying with ASTM A 1008, commercial steel, exposed.
- 2. Steel Members Fabricated from Plate or Bar Stock: ASTM A 529 or ASTM A 572, 42,000-psi minimum yield strength.
- 3. Reinforcing bars for concrete footings to be ASTM A 615 / A 615M, Grade 60, as required by engineering.
- 4. Galvanized Steel Sheet: ASTM A 653, G90 coating, either commercial or forming steel.
- 5. Fabrication
 - a. Surface Preparation: Remove mill scale and rust, if present, from uncoated steel, complying with SSPC-SP 5/NACE No. 1, "White Metal Blast Cleaning," or SSPC-SP 8, "Pickling."

- b. All steel shall be galvanized in accordance with ASTM-A123.
- c. For steel exposed to view on completion, provide materials having flat, smooth surfaces without blemishes. Do not use materials whose surfaces exhibit pitting, seam marks, roller marks, rolled trade names, or roughness.

D. Stainless Steel

- 1. Stainless-Steel Sheet: ASTM A 240 or ASTM A 666, stretcher-leveled standard of flatness. Type 304 for interior applications and Type 316 or 316L for exterior applications.
- 2. Finishes
 - a. Color as indicated on Contract Documents.

E. Welding

- 1. Welding materials and practices shall conform to the requirements of the latest edition of American Welding Society code for steel and aluminum. Shop welders shall be certified by AWS. Welding rods shall be of a composition compatible to the base metal being welded.
- 2. Fabrication shall be accomplished using the highest standards of workmanship. All pieces shall be saw cut and carefully fit together. All visible connections shall be full welded and ground flush and smooth. All visible surfaces and connections shall be without visible grounding marks, surface differentiation or variation.

F. Hardware

- 1. Anchor bolts shall conform to ASTM-A576 with a minimum yield strength of 50,000 PSI. Hexagonal nuts and washers shall be furnished with each bolt.
- 2. High strength bolts (other than anchor bolts), nuts and washers shall conform to ASTM-A325.
- 3. Nelson type threaded studs shall be low carbon mild steel with a minimum yield strength of 50,000 PSI.
- 4. Non-ferrous metal or hot-dip galvanized anchors and inserts for exterior installations and elsewhere as required for corrosion resistance and to prevent staining of surrounding surfaces. Use toothed steel or lead expansion-bolt devices for drilled-in-place anchors. Furnish inserts, as required, to be set into concrete or masonry work.
- 5. Where mechanical fasteners and hardware are required, they shall be of adequate thickness, length and construction to properly secure the sign unit. Any visible portion of any mounting device shall be finished to match adjacent sign surface, unless otherwise specified.
- 6. All exposed screws shall be countersunk, tamper resistant, and painted to match adjacent surface unless otherwise noted.

- 7. Metal fasteners and hardware in contact with dissimilar metals shall have a protective coating or neoprene shields to prevent electrolytic and galvanic action.

8.

- G. Breakaway Base: Manufacturer shall provide ConDOT approved breakaway posts for the sign types and locations indicated in the Contract Documents. Final designs and shop drawings shall be supplied by the Sign Contractor for each of the poles identified. A Connecticut licensed Professional Engineer shall sign and seal the submittal of shop drawings. The breakaway post shall meet or exceed the following criteria: [NOTE to OWNER: edit as needed, Delete if not required]

- 1. 2004 AASHTO A policy on Geometric Design of Highway and Streets
- 2. 2002 AASHTO Standard Specification for Structural supports for Highway Signs, Luminaries and Traffic Signals
- 3. 2003 AASHTO Roadside Design Guide

H. Acrylic

- 1. Acrylic Sheet: ASTM D 4802, Category A-1 (cell-cast sheet), Type UVA (UV absorbing). Premium quality manufactured by Rohm and Haas (Plexiglas), Du Pont (Lucite), American Cyanamid, or approved equal.
 - a. Non-Glare Acrylic Sheet for Insert Signs: Premium quality manufactured by Rohm and Haas, Du Pont, American Cyanamid or approved equal equal.
 - b. Non-Glare Frosted Acrylic: Acrylite P95 White Acrylic, or approved equal.
- 2. Acrylic Sheet Fabrication
 - a. Provide acrylic sheet components and drilled holes with smooth edges free from saw marks, chips, cracks or other blemishes and square to the faces.
 - b. Machine or hand polish visible edges unless specified otherwise. Flame polishing is not permitted.
 - c. Size and cut acrylic sheet scheduled to be 'glazed' or contained in a frame, as required to allow for expansion and contraction.
 - d. Provide laminated sheets and welded joints free from gaps and bubbles; continuously sealed and clear.
 - e. Use special care in the fabrication and installation of acrylic sheets to prevent scratching, staining or other imperfections.
 - f. When there is no possibility or danger from other work to be performed, remove protective coverings on acrylic sheets and remove scratches using approved acrylic polish.

Remove internal and external dust and other dirt.

- g. Treat surfaces with anti-static polish on completion.
- h. Provide Owner with complete cleaning instructions recommended by acrylic manufacturer for safe cleaning of acrylic sheets.

I. Adhesives and Tapes

1. Adhesives required in fabrication and installation of exterior component shall be compatible with the materials to be laminated or adhered and **shall only be used as redundant to mechanical fasteners.**
2. Use silicone and epoxy adhesives recommended for exterior applications in accordance with the recommendations of the manufacturer of the adhesives and the material to be laminated or adhered.
3. Surfaces on which adhesives are to be applied shall be smooth, clean and free of dust, dirt, grease, fingerprints or other foreign matter.
4. Adhesives shall be guaranteed not to deteriorate, discolor, delaminate or fail in adhesion for any reason including exposure to heat, sunlight, weathering or other environmental conditions.
5. Adhesives shall not change the color of, or in any way deteriorate, the materials to which they are being applied.
6. Visible joints shall be even and free from air bubbles and other defects.
7. Adhesive Tapes
 - a. VHB mounting tapes for permanent installation shall be premium quality double-coated acrylic tape such as manufactured by 3M (VHB Tape) or approved equal. Urethane foam tapes will not be allowed.
 - b. Unless otherwise indicated, when used for permanent installation, adhesive mounting tape shall be 1/2" wide and 1/16" thick. Coverage shall be at least one continuous strip of tape at four-inch intervals. No tape shall be closer than 1/4" from the edge of any component.
8. Construction Adhesives
 - a. Silicone adhesives shall be clear, ready-to-use, high performance, premium quality materials, such as manufactured by General Electric (GE 1200), or approved equal.
 - b. Epoxy adhesives shall be two-component, thermal-setting, premium quality materials such as manufactured by Devcon (Two-Ton Epoxy), or approved equal.

J. Vinyl

1. Provide opaque, non-reflective vinyl film with repositionable adhesive backing, suitable for interior and exterior applications. Use positionable and pressure activated adhesive. Apply adhesive only when minimum application temperature is 40°F (4°C), and maximum application temperature is 100°F (38°C). Provide film with a seven (7) year exposure life, when applied in accordance with manufacturer's recommended procedures.

K. Concrete

1. Portland cement, ASTM C 150, Type 1; Fly ash, ASTM C 618, Class F
2. Normal weight aggregate, ASTM C 33, uniformly graded with a nominal maximum aggregate size of 3/4 inch. Combined aggregate gradation not more than 18 percent and not less than 8 percent on an individual sieve.
3. Potable water complying with ASTM C 94

L. Concrete footings

1. Footings for signs to be cast-in-place concrete with reinforcing steel bars as required. Design, engineering, and installation are the responsibility of the Sign Contractor.
2. Sign Contractor shall provide shop drawings and engineering calculations prepared and sealed by a registered professional engineer, licensed in the State of Connecticut. Formwork detailing and engineering shall be prepared under direct supervision of a registered professional engineer, licensed in New York.
3. Regulatory requirements shall conform to local laws, codes, and regulations. Sign Contractor shall submit formwork drawings, calculations, and other data to local authorities as they may require.
4. Typical formwork shall be plywood, metal, or other panel-type materials providing continuous smooth surfaces, non-reactive with form release agent or water. Formwork shall be furnished in largest practicable sizes to minimize number of joints. Provide form material with sufficient thickness to withstand pressure of newly placed concrete without bow or deflection. Conform to joint system indicated on drawings or accepted shop drawings.
 - a. Form ties shall be factory-fabricated, adjustable-length, removable or snap-off metal form ties designed to prevent form deflection and to prevent spalling of concrete upon removal. Sign Contractor shall provide ties that will leave no metal closer than 37mm (1 - 1/2") from face of exposed concrete surface, and, when removed, will leave holes not larger than 25mm (1") diameter in concrete surfaces.
 - b. Form release agent shall be colorless material, with maximum volatile organic compounds (VOCs) of 350 gm per liter; non-staining; which will not bond with or adversely affect concrete surfaces and which will be compatible with

subsequent treatments of concrete surfaces.

- c. Fabricate formwork to prevent leakage of cement paste during concrete placement. Solidly butt joints and provide back-up material at joints. Minimize joints. Provide removable panels at bottom of column, pier, wall, and other forms where necessary to facilitate cleaning and inspection. Fabricate forms for easy removal without hammering or prying against concrete surfaces.
 - d. Install forms in accordance with ACI 301, except for more stringent requirements of specifications or the formwork design engineer. Brace formwork to ensure stability.
5. Irregularities in formed surfaces shall conform to requirements of ACI 347, as follows:
 - a. Class A: For concrete surfaces exposed to view.
 - b. Class C: For other concrete surfaces
 6. Sign Contractor shall provide formed concrete, and concrete slab edges, that are maximum +/- 12mm (1/2") from designated design plane in any location.
 7. Application of form release agent shall be applied in accordance with manufacturer's instructions. Apply prior to placing reinforcing steel, anchoring devices, and embedded items. Do not apply where concrete surfaces are scheduled to receive finishes which may be affected by agent. Soak surfaces of untreated forms with clean water. Keep surfaces wet prior to placing concrete.
 8. Inserts, embedded items, and openings shall be provided with formed openings where required for work embedded in or passing through concrete.
 9. Coordinate work of other sign parts in forming and setting openings, slots, recesses, chases, sleeves, bolts, anchors, and other inserts.
 10. Adjustments to formwork shall be checked before placing reinforcements and continuously during concrete placement to verify that work will be within specified tolerances. Conform to requirements of ACI 347. Correct excessive settlement or distortion of forms during concrete placement. Retighten forms during concrete placement if required to eliminate mortar leaks.
 11. Form removal shall occur after concrete has sufficient strength to support its own weight and construction, design, or other loads which may be imposed upon it. Remove formwork that does not support loads when the following conditions are met:
 - a. Concrete has cumulatively cured at not less than 10°C (50°F) for 24 hours.
 - b. Concrete is sufficiently hard that form removal will not damage it.
 - c. Curing and protection operations are maintained.

- d. Remove formwork supporting loads when concrete has attained required stripping strength. Do not remove formwork until slab finishing tolerances have been measured. Remove formwork progressively so no unbalanced loads are imposed on structure. Do not damage concrete surfaces during form removal.
- 12. Clean forms to remove foreign matter as erection proceeds. Use compressed air to remove foreign matter. Ensure that water and debris drain to exterior through clean-out ports. During cold weather, remove ice and snow from forms. Do not use deicing salts. Do not use water to clean out completed forms unless formwork and construction proceed within heated enclosure.

2.2 FINISHES

A. Paints, Inks, Coatings

1. All colors shall be exactly reproduced as specified and shall match submitted samples.
2. Paint Manufacturer:
 - a. AkzoNobel, or Approved Equal
3. All exposed surfaces to receive satin finish anti-graffiti UV clear coating
 - a. Matthews Paint Super Satin Clearcoat: 1.24 low VOC, acrylic polyurethane clear coat with 10-year life expectancy, or Approved Equal.
4. All paint shall be applied using a high pressure spray in dust-free conditions and shall be allowed to dry or cure properly before being moved.
5. Painted surfaces and other applied finishes shall have a smooth, even finish and be free of imperfections, marks, scratches, embedded dirt, wave patterns or other irregularities.
6. Paint required in fabrication, including paint for lettering, screened copy, subsurface copy, etc. shall be compatible with the materials to which it is applied and shall be guaranteed not to cause discoloration, deterioration or delamination for any reason, including exposure to heat, sunlight, weathering or other environmental conditions.
7. Inks for silkscreen graphics shall be non-glare, eggshell, or semi-matte unless otherwise specified on drawings.
8. Paints shall be precisely identified on the shop drawings and submitted samples.
9. Prime coats or other surface pre-treatments, where recommended by the manufacturer of the paint, shall be included in the work.

2.3 GRAPHICS AND PROCESSES

A. General

1. Graphics shall be highest quality with sharp lines and smooth curves. Images shall be uniform colors and free from streaks or spotting.
2. Scalable vector art for Symbols as shown on Contract Documents shall be provided digitally by Design Consultant in Adobe Illustrator format for placement on final sign layouts. All other artwork required shall be produced by the Sign Fabricator.
3. Sign Fabricator shall apply messaging from Message Schedule to provide all unique sign layouts that comply with requirements indicated for size, style, spacing, content, position, material, finishes, and colors of letters, numbers, and other graphic devices shown on the Contract Documents.

B. Typography and Layout

1. The contractor is responsible for purchasing specified typefaces.
 - a. The typeface in use for the Project is Scout in multiple weights as specified on the Contract Documents.
2. The layout of the copy on the drawings and the wording indicated is for placement only. Should any conflict arise in the final copy layout, notify the Design Consultant before proceeding. In no event shall size, number of lines of copy or specified letter, word and/or line spacing be modified to get copy to fit.

C. Silkscreening

1. General
 - a. Silk screens shall be made using photographic film positives. Hand-cut positives may not be used except in exceptional circumstances and only with the Designer's prior approval in writing. If hand-cut positives are allowed, they shall be of equivalent quality to photographic film.
 - b. Ink finish shall be non-glare, 'eggshell' or semi-matte, unless otherwise specified.
2. Sub Surface
 - a. Subsurface silk screening shall consist of a reverse (flopped) image screened onto the back surface of specified materials with compatible paints or inks. When the screened image is dry the entire surface shall be backpainted with the specified background color.
 - b. Use reverse silk-screen process to print copy; overspray the copy with an opaque background color coating.
 - c. Use DuPont "Chromalin" heat and pressure-laminated photo polymer film system to form copy and background color.

3. Silk screening shall be highest quality, with sharp lines, no sawtooths, or uneven ink coverage.
4. Screens shall be photographically reproduced.
5. Background ink shall be process inks as recommended by manufacturer of substrate employed.
6. Ink application through screens: 1 flood pass and 1 print pass. Images: uniform color and ink thickness; free from squeegee marks and lines.
7. Signs: dry in adequate racks with 2 in. spacing for ample air flow and forced air drying and curing.
8. Package signs only after they have dried completely per ink manufacturer's time allowances.

D. Die-Cut Vinyl Letters

1. Provide right-reading or reverse-reading characters and graphics as indicated by the Contract Documents. Electronically cut from vinyl film with adhesive backing.

E. Sign Panels: Provide smooth sign panel surfaces constructed to remain flat under installed conditions within a tolerance of plus or minus 1/16 inch measured diagonally from corner to corner.

1. Coordinate dimensions and attachment methods to produce message panels with closely fitting joints. Align edges and surfaces with one another in the relationship indicated.
2. Increase metal thickness or reinforce with concealed stiffeners or backing materials as needed to produce surfaces without distortion, buckles, warp, or other surface deformations.
3. Continuously weld joints and seams, unless other methods are indicated; grind, fill, and dress welds to produce smooth, flush, exposed surfaces with welds invisible after final finishing.

F. Illumination

1. Illumination Product: Provide 3M Flexible Light Mat Series 3635-1000 LED sheet, or Approved Equal.
2. LED unit life to exceed 50,000 hours at 100% brightness
3. Color temperature: 3500 Kelvin, "Bright White"
4. Use only high quality / high brightness 12VDC LED's
5. Lighting to provide even and consistent distribution of illumination. Illumination shall be of a consistent intensity and color within each individual sign unit, and between all illuminated sign elements in the program. Color value and intensity will be reviewed by Owner on-site, with the use of fully functioning prototypes prepared by the Sign Contractor prior to final fabrication.

- G. Digital-to-Substrate Graphics
 1. Large format flat bed UV curable graphics shall be full-color CMYK + White of at least 300 dpi resolution.
 2. Colors shall exhibit full coverage without any transparency or knockouts, unless specified. Where necessary, a white base layer shall be laid down prior to color printing to achieve maximum color vibrancy. Where necessary, multiple passes shall be employed to achieve suitable color densities.

PART 3 – EXECUTION

3.1 GENERAL INSTRUCTIONS

- A. It shall be assumed that the Contractor has inspected the site and is aware of all site and operational conditions affecting the fabrication and installation of the work. No extra charges shall be claimed or allowed due to a failure of the Contractor from making such inspections.
- B. Failure to request clarification of any inadequacy, omission or conflict will not relieve the Contractor of responsibility.
- C. All work shall be performed in accordance with the written schedule agreed on by Owner, Design Consultant and Sign Installer. In any case where work cannot be completed on schedule, the Contractor shall supply temporary signs at no additional expense to the Owner.

3.2 FABRICATION

- A. All submissions shall be reviewed and have received final approval by Design Consultant, in addition to stamped engineering drawings where required, prior to fabrication of project sign requirements.
- B. Confer with the Design Consultant regarding all critical items and advise the Design Consultant of any significant discrepancies in field measurements or operational difficulties prior to fabrication. Obtain the Design Consultant's written approval for any resulting deviations from the specifications and/or approved shop drawings that may become necessary.
- C. All work shall be constructed as complete systems, including all stiffeners, fasteners, welding, sealants, jointing, miscellaneous pieces and material thicknesses, etc.
- D. Unless otherwise shown on the Drawings, all members shall be continuous lengths without seams. Work shall be formed to profiles indicated on the Drawings.
- E. Where material lengths require joints, all joints shall be flush. Similar materials at joints shall be either bonded or welded together, or shall be lap jointed to provide for expansion. All joints to be light proof.

- F. Preassemble signs in the shop to the greatest extent possible to minimize field assembly. Disassemble signs only as necessary for shipping and handling limitations. Clearly mark units for reassembly and installation, in a location not exposed to view after final assembly. All work "broken down" shall be erected so that all parts fit accurately with hairline joints.
- G. Work shall be performed by competent workmen and shall be of the best quality, free from defects impairing strength, durability and appearance. All items shall be made of new materials and be uniform in detail design and finish.
- H. Methods of fabrication, joining, finishing and installation of all components and work shall be according to the manufacturer's instructions for the use of any products, materials, fittings and equipment used in their construction.
- I. All details of construction are to be engineered with appropriate strength materials and finished to withstand the potential rigors of their installed locations.

3.3 PERMITS

- A. Sign Contractor shall obtain all permits required by Local Authorities for installation of signs.

3.4 INSTALLATION

- A. Install the work in a well organized and timely manner. Whenever possible, the work shall be installed as one continuous activity. The installation process shall be coordinated to accommodate the needs of both the Owner and Design Consultant.
- B. Coordinate all scheduling and installation procedures with the Owner, Design Consultant, General Contractor and others to avoid delays or additional costs.
- C. Inform the Design Consultant, at least two weeks in advance, of any intended installation and arrange, at the Design Consultant's convenience to have all patterns in place, and initial signs of each type ready for installation and approval by the Design Consultant on site before proceeding with the rest of the installation. It is important that such approval processes be organized efficiently so that approvals can take place in a timely manner.
- D. Sign Contractor is responsible for verifying all field conditions and dimensions prior to fabrication and installation. Should Sign Installer find any discrepancies during installation, they shall notify the Design Consultant at once, to await clarification, prior to proceeding.
- E. Prepare all encountered surfaces as required to receive signage.
- F. Install all signs at the locations and heights specified in the Contract Documents.

- 1. Mount signs at projection distance from wall surface indicated.
 - 2. All signs shall be installed level and plumb and parallel to the surface upon which they are mounted, unless otherwise specified.
 - 3. Use mounting methods of the type described and in compliance with the manufacturer's instructions.
 - 4. For signs installed at exterior locations, include all elements recommended by manufacturers and good practice to insure weatherproofing for internal and external parts and materials.
 - 5. Where appropriate, notify Design Consultant in writing of any visual or physical conflicts. Neither the Owner nor the Design Consultant will be responsible for oral instructions.
- G. Follow recommendations and instructions for installation as provided by component manufacturers. Notify the Design Consultant in writing if such installation will not provide permanent, rigid installation within site conditions.
 - H. Dimensional Characters: Mount characters using fastening methods to comply with approved shop drawings and/or as required by character form, wall construction, and condition of exposure. Provide heavy paper template pattern to establish character spacing and to locate holes for fasteners.
 - I. Wall-Mounted Panel Signs: Attach panel signs to wall surfaces using the methods indicated below:
 1. Vinyl-Tape Mounting: Use double-sided foam tape to mount signs to smooth, nonporous surfaces. Do not use this method for vinyl-covered or rough surfaces.
 - a. Adhesive foam mounting tape shall be 1/2" wide and 1/16" thick. Coverage shall be at least one continuous strip of tape at four inch intervals. No tape shall be closer than 1/2" from the edge of any component
 2. Silicone-Adhesive Mounting: Use liquid silicone adhesive recommended by the sign manufacturer to attach sign units to irregular, porous, or vinyl-covered surfaces. Use double-sided vinyl tape where recommended by the sign manufacturer to hold the sign in place until the adhesive has fully cured.
 3. Shim Plate Mounting: Provide concealed shim panels in the material identified in the Contract Documents, at all locations indicated. Attach the plate with fasteners and anchors suitable for secure attachment to the substrate. Attach panel sign units to the plate using the method specified above.
 - J. Bracket-Mounted Signs: Provide brackets, fittings, and hardware for mounting signs that project at right angles from walls and ceilings to comply with approved shop drawings and/or as required by wall construction and condition of exposure. Attach brackets and fittings securely to walls and ceilings with concealed fasteners and anchoring devices to comply with manufacturer's written instructions.

- K. No installation procedures or materials shall be used that will in any way change the visual quality or in any manner have an adverse effect on adjacent materials and surfaces.
- L. Protect all adjacent surfaces from damage during installation. Restore or replace any damaged surfaces to original condition and appearance.

3.5 CLEANING AND PROTECTION

- A. All work shall be provided with suitable protective coverings during shipment and installation. Remove and replace protective coating for inspection when requested. Final removal of protective coatings shall take place only when there is no danger of damage from further work, and all protective coatings shall be removed simultaneously from similarly finished items to prevent uneven oxidation or discoloration.
- B. Remove packing and construction materials from the site. Leave premises broom clean and ready for work under other contracts or ready for use. Vacuum any carpets and spot clean where if necessary.

- C. All existing exterior surfaces within (5) feet of installed signs to be returned to the same condition and quality that was present before the installation of signage, including material, finish, grading, and landscaping.
- D. At completion of the installation, clean soiled sign surfaces in accordance with the manufacturer's instructions. Exposed surfaces of all work shall be left clean and free of glue, fingerprints, dirt, grease, dust or any other imperfections.
- E. Protect units from damage until acceptance by the Owner
- F. Names, stamps and decals of manufacturers, installers or maintainers of signs shall not be visible in the finish work.

3.6 INSPECTION AND PUNCHLIST

- A. Provide access to the Design Consultant to inspect all work in progress at the site of fabrication and/or installation.
- B. Final Punch List will be conducted by Owner and Design Consultant.

3.7 CLOSE OUT SUBMISSIONS

- A. Maintenance Manual: Sign Contractor shall turn over to Owner all operating and maintenance data, warranties, and bonds, spare parts, and maintenance materials as applicable.
- B. Record Drawings: Provide the following
 1. One (1) digital copy of As-Built shop drawings, including Graphic Layouts, no larger than 11 x 17. Drawings are to include all final notes, dimensions and drawing.
 2. One (1) digital copy of final Sign Location Plans
 3. One (1) Record Set of Specifications including addenda and contract modifications.
 4. One (1) Record set Product Data, insert into maintenance manual when required as part of operations and maintenance.

END OF SECTION

Double-sided variation is permissible on a case-by-case basis upon request to the University's Representative.



2 Plan - Sign Types B1, B2, B3
1/2" = 1'-0"

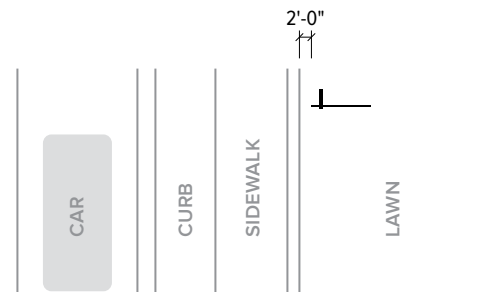

4 Installation Plan - Sign Type B1 (Typical)
NTS

NOTE: Sign orientation to be determined by University Representative

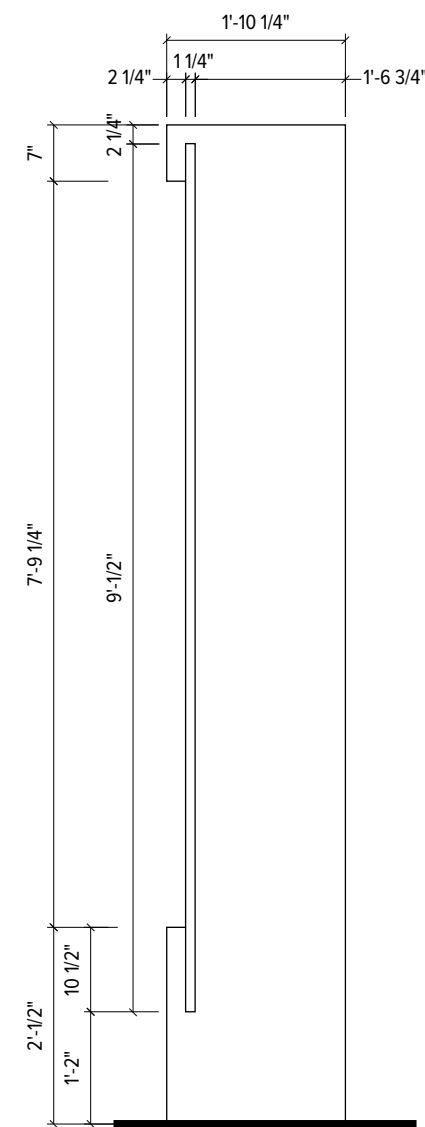
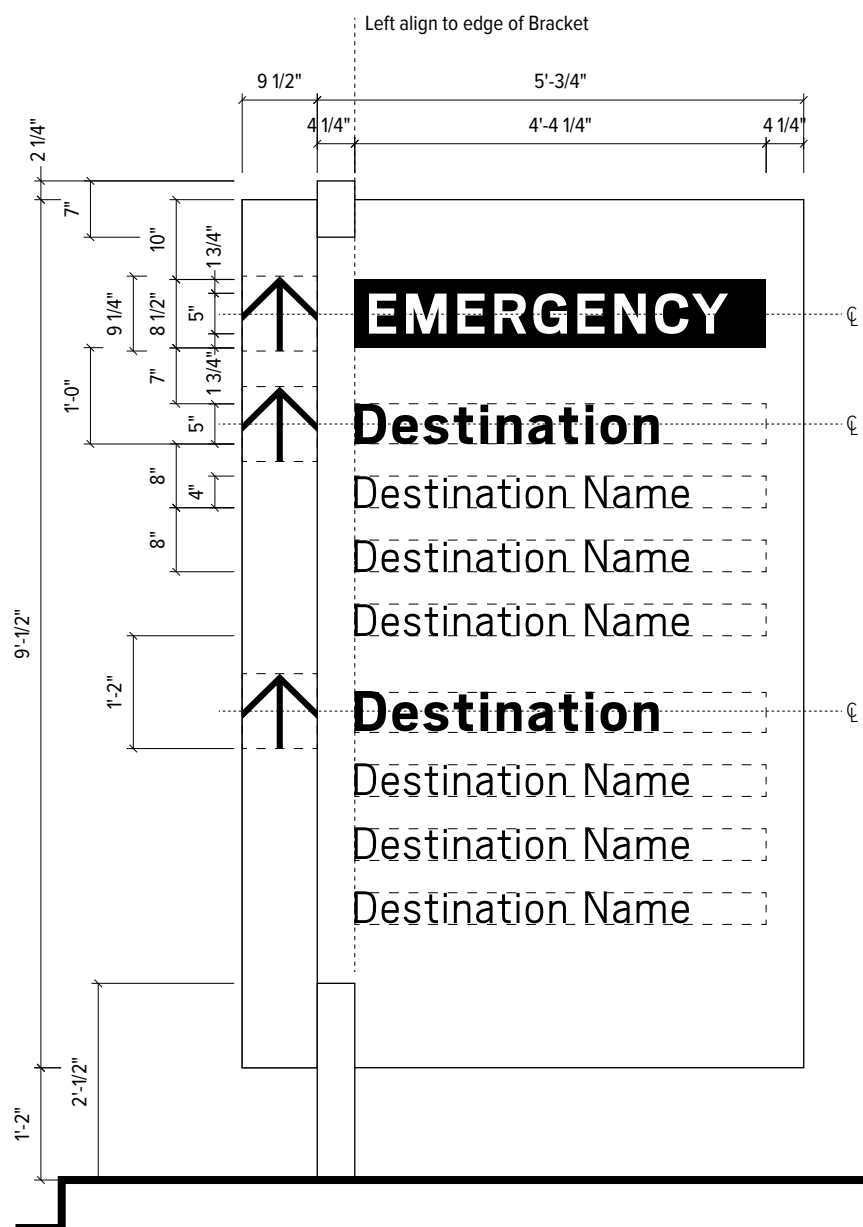
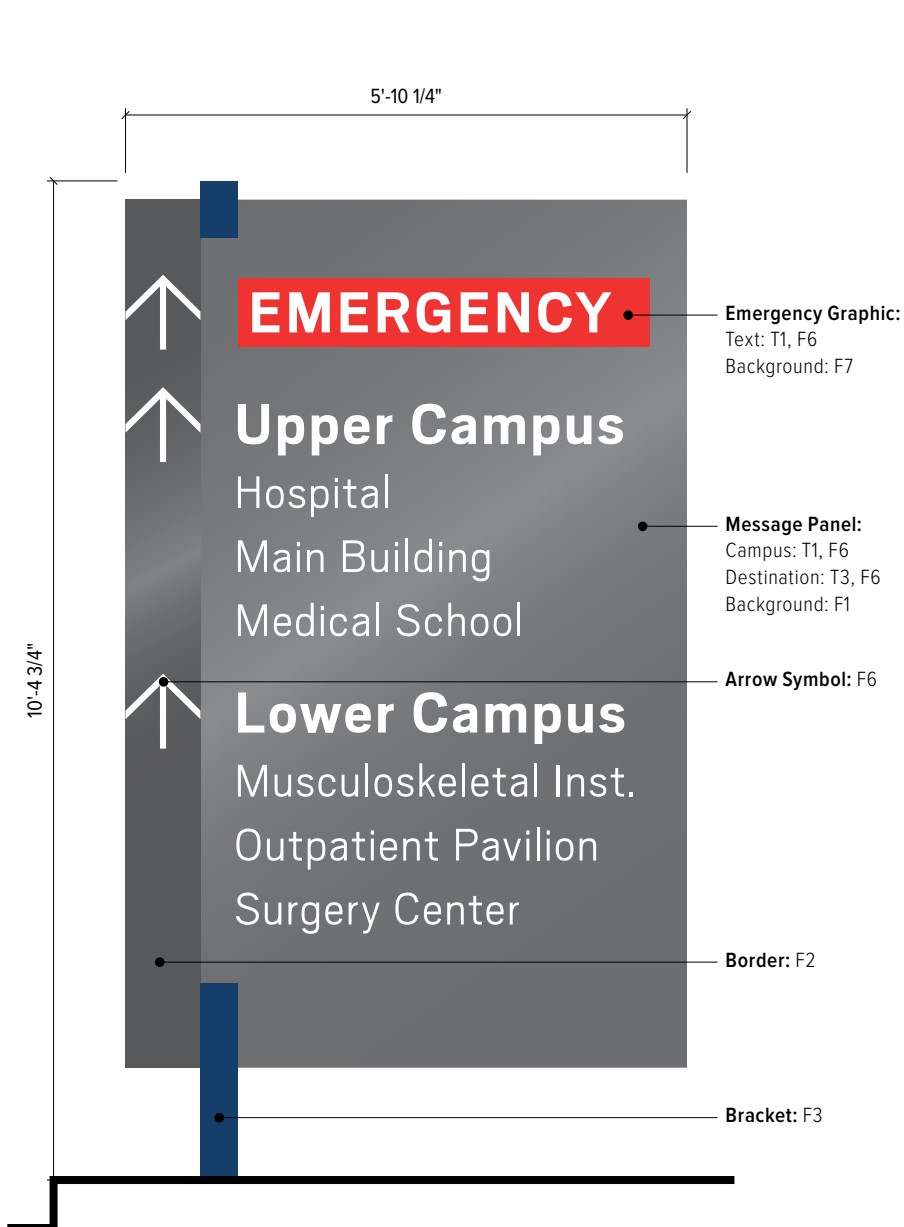

TWO TWELVE

902 BROADWAY
FLOOR 20
NEW YORK, NY
10010/6002
212 254/6670 T
212 254/6614 F

For Planning & Coordination Only –
Not for Construction

This document and the entirety of its contents are property of 212/Harakawa Inc. and/or Two Twelve Associates, Inc. No part of this document shall be duplicated, disseminated, distributed or used for any purpose without express written permission.

Do not use for final construction. Sign fabricator to verify and be responsible for all dimensions and work conditions and inform this office of variations prior to performing work. Written dimensions govern over scaled dimensions.

No. Revisions

Date 15 May 2017

Project No. UCONN-046

Phase CID

Project Title
University of Connecticut
Campus Wayfinding

Sign Type B1
Primary Vehicular
Directional

CID.08

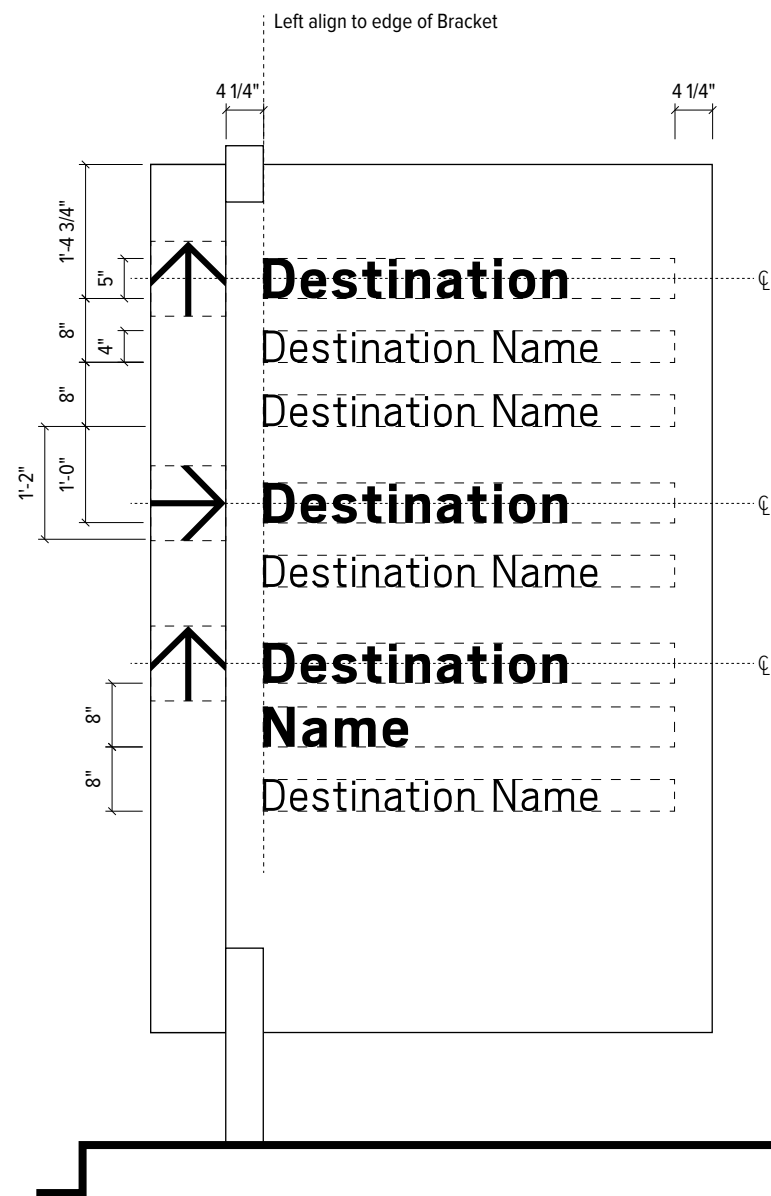

1 Alternate Graphic Layout - Sign Type B1
1/2" = 1'-0"

TWO TWELVE

902 BROADWAY
FLOOR 20
NEW YORK, NY
10010/6002
212 254/6670 T
212 254/6614 F

For Planning & Coordination Only –
Not for Construction

This document and the entirety of its contents are property of 212/Harakawa Inc. and/or Two Twelve Associates, Inc. No part of this document shall be duplicated, disseminated, distributed or used for any purpose without express written permission.

Do not use for final construction. Sign fabricator to verify and be responsible for all dimensions and work conditions and inform this office of variations prior to performing work. Written dimensions govern over scaled dimensions.

No.	Revisions

Date 15 May 2017

Project No. UCONN-046

Phase CID

Project Title

University of Connecticut
Campus Wayfinding

Sign Type B1
Primary Vehicular
Directional

CID.09

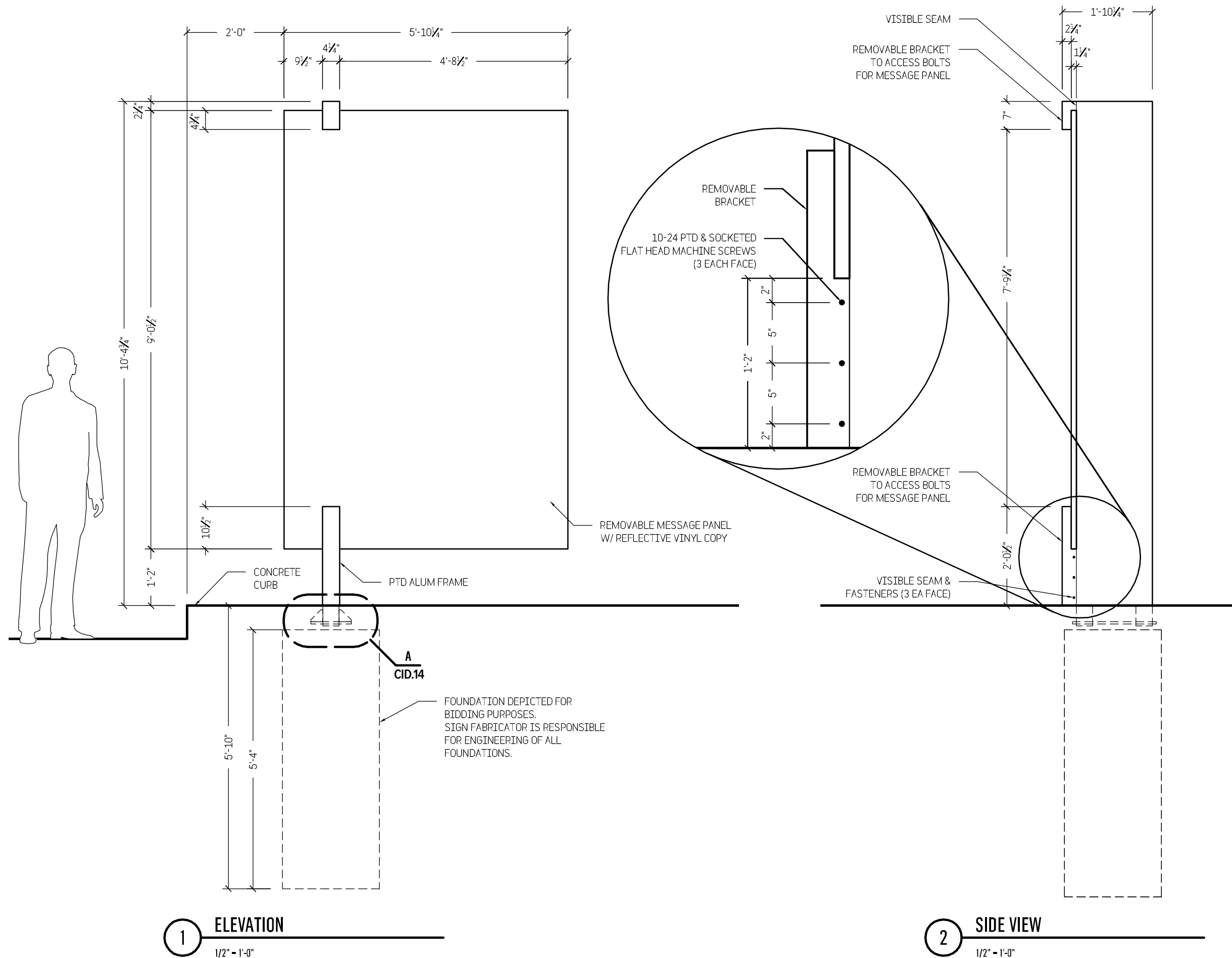

TWO TWELVE

902 BROADWAY
 FLOOR 20
 NEW YORK, NY
 10010/6002
 212 254/6670 T
 212 254/6614 F

For Planning & Coordination Only –
 Not for Construction

This document and the entirety of its contents are property of 212/Harakawa Inc. and/or Two Twelve Associates, Inc. No part of this document shall be duplicated, disseminated, distributed or used for any purpose without express written permission.

Do not use for final construction. Sign fabricator to verify and be responsible for all dimensions and work conditions and inform this office of variations prior to performing work. Written dimensions govern over scaled dimensions.

No.	Revisions

Date 15 May 2017

Project No. UCONN-046

Phase CID

Project Title

University of Connecticut
 Campus Wayfinding

Sign Type B1
Primary Vehicular
Directional

CID.10

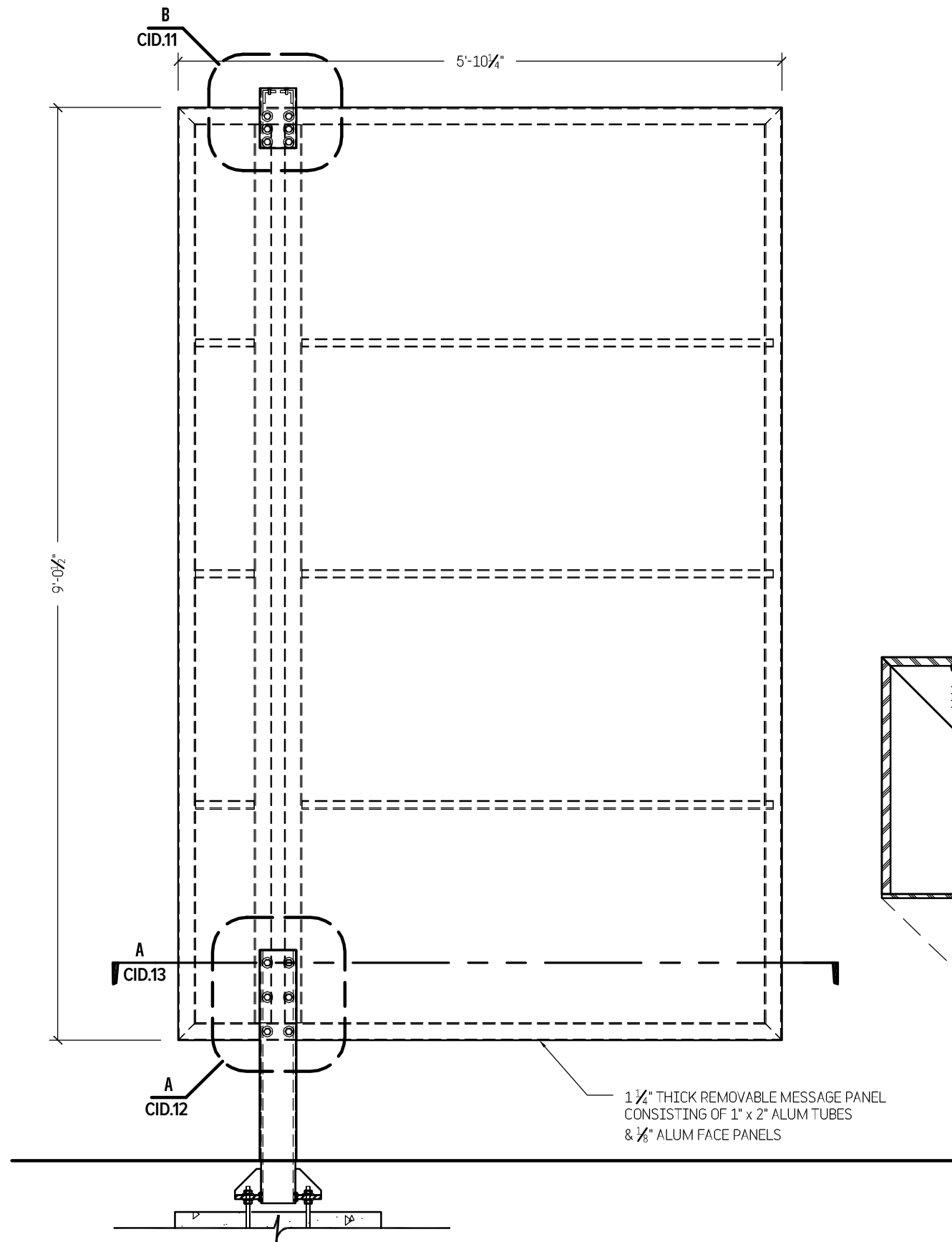

A SECTION
3/4" = 1'-0"

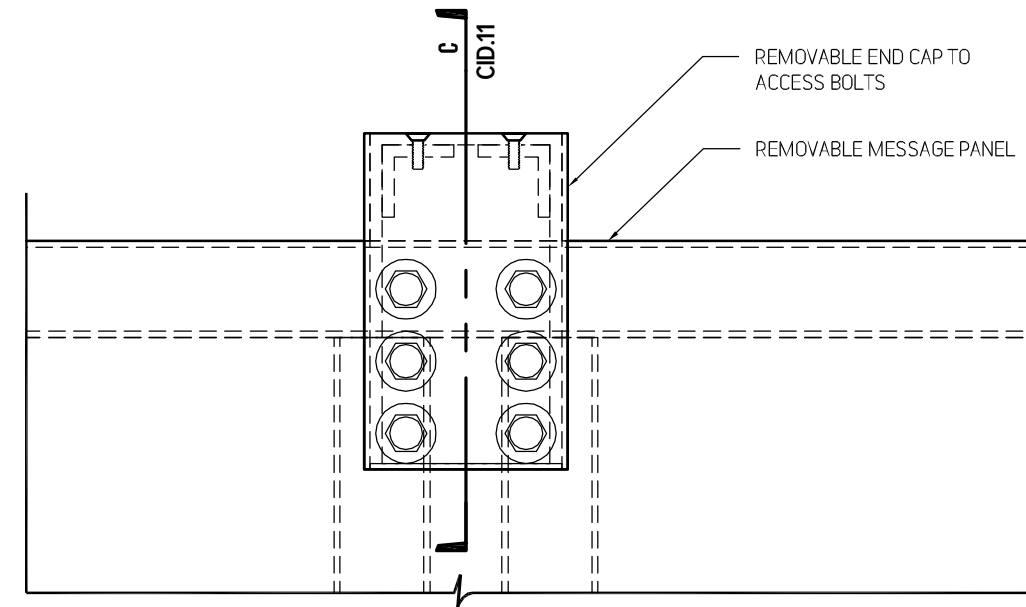

B SECTION
3" = 1'-0"

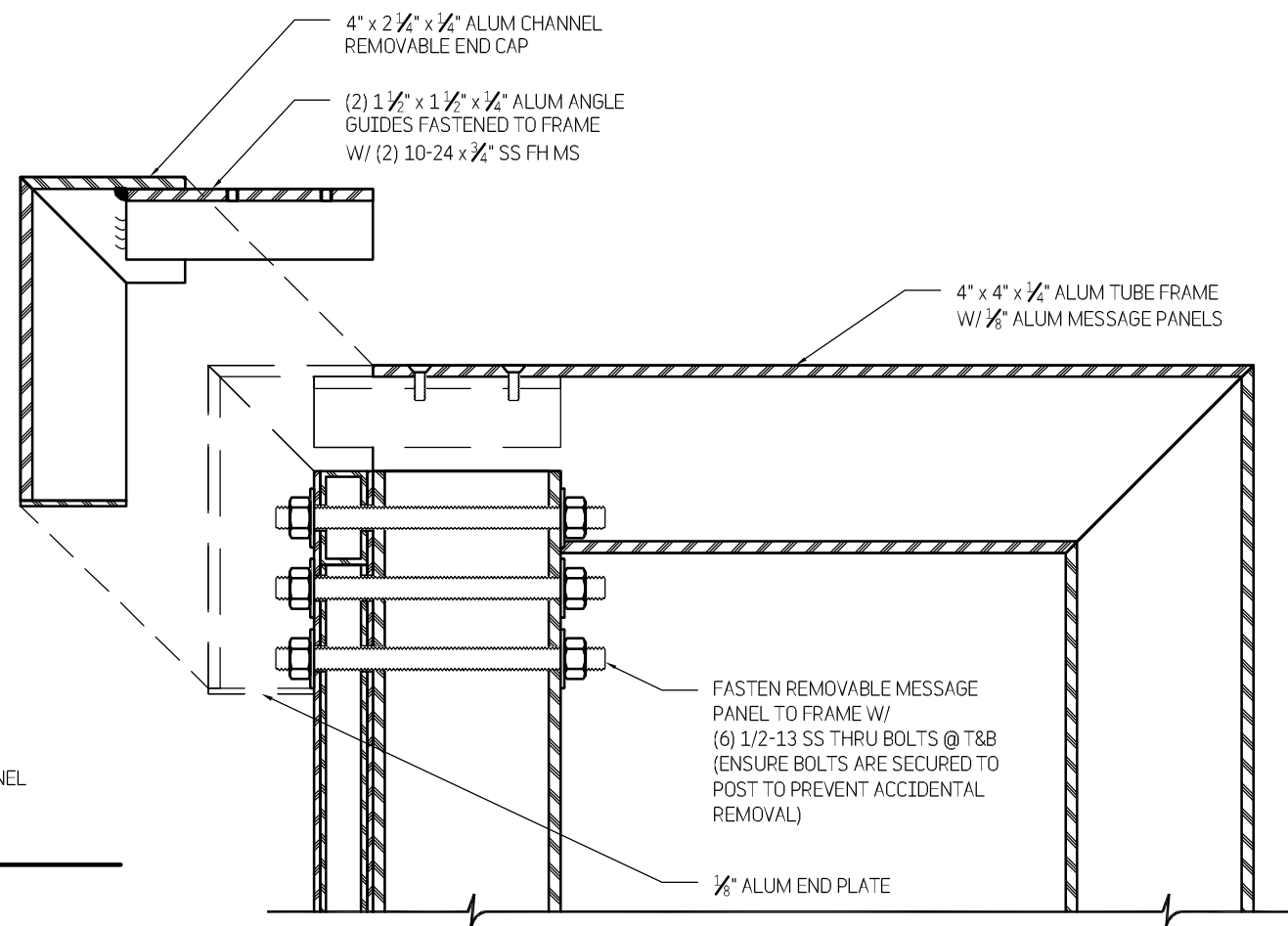

C SECTION
3" = 1'-0"

TWO TWELVE

902 BROADWAY
 FLOOR 20
 NEW YORK, NY
 10010/6002
 212 254/6670 T
 212 254/6614 F

For Planning & Coordination Only –
Not for Construction

This document and the entirety of its contents are property of 212/Harakawa Inc. and/or Two Twelve Associates, Inc. No part of this document shall be duplicated, disseminated, distributed or used for any purpose without express written permission.

Do not use for final construction. Sign fabricator to verify and be responsible for all dimensions and work conditions and inform this office of variations prior to performing work. Written dimensions govern over scaled dimensions.

No.	Revisions

Date 15 May 2017

Project No. UCONN-046

Phase CID

Project Title
University of Connecticut
Campus Wayfinding

Sign Type B1
Primary Vehicular
Directional

CID.11

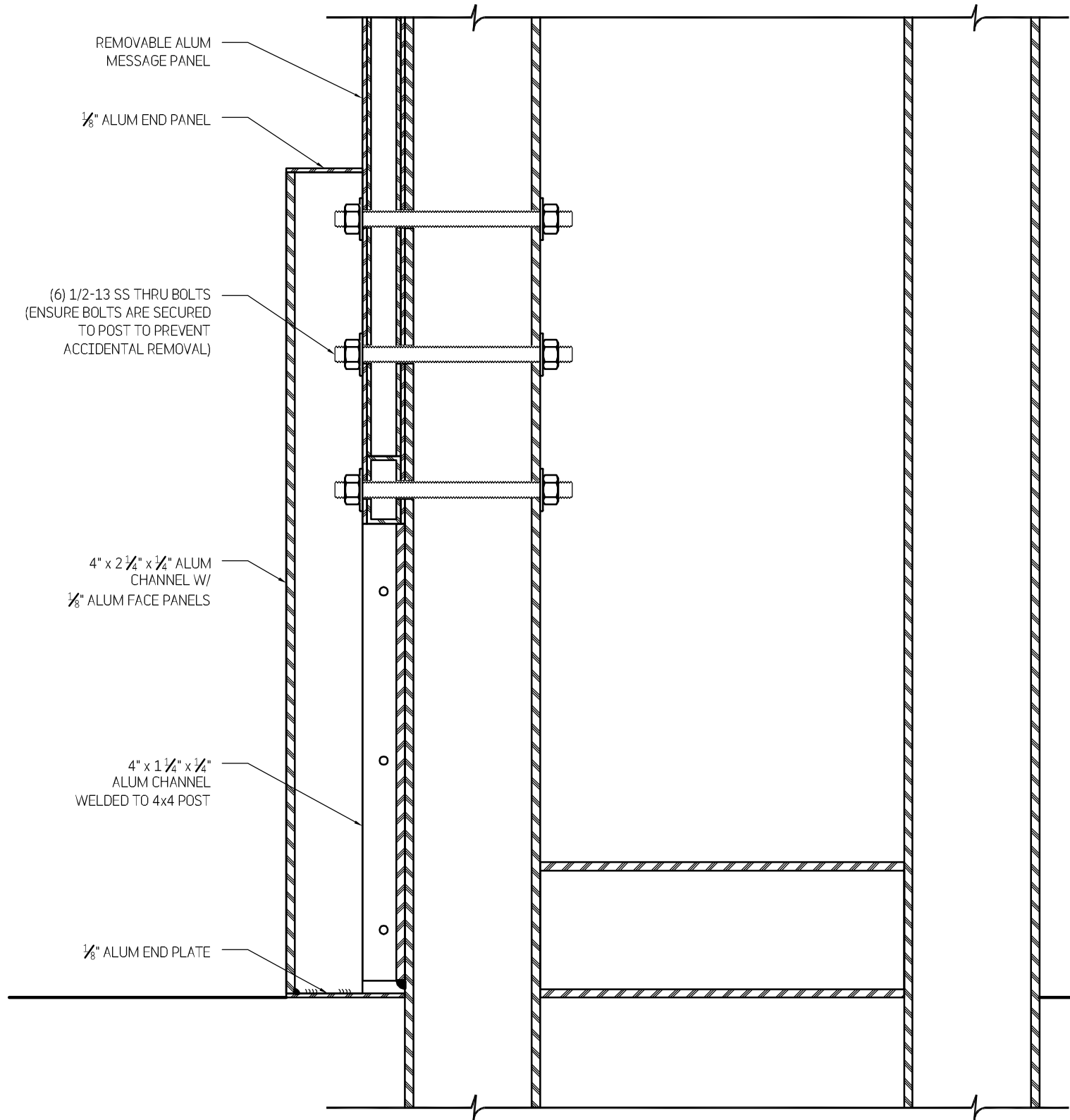
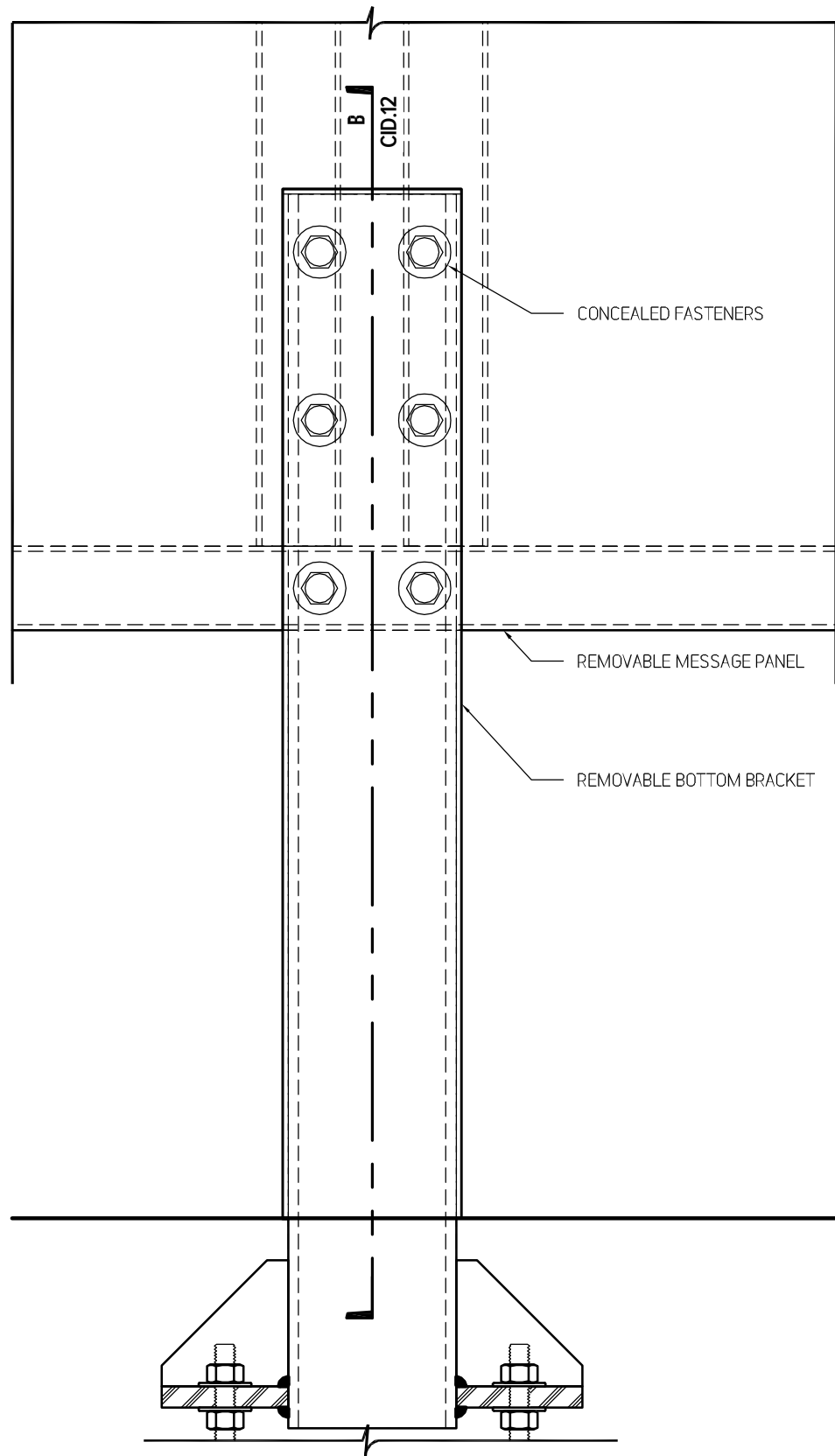

TWO TWELVE

902 BROADWAY
 FLOOR 20
 NEW YORK, NY
 10010/6002
 212 254/6670 T
 212 254/6614 F

For Planning & Coordination Only –
 Not for Construction

This document and the entirety of its contents are property of 212/Harakawa Inc. and/or Two Twelve Associates, Inc. No part of this document shall be duplicated, disseminated, distributed or used for any purpose without express written permission.

Do not use for final construction. Sign fabricator to verify and be responsible for all dimensions and work conditions and inform this office of variations prior to performing work. Written dimensions govern over scaled dimensions.

No.	Revisions

Date 15 May 2017

Project No. UCONN-046

Phase CID

Project Title
 University of Connecticut
 Campus Wayfinding

Sign Type B1
Primary Vehicular
Directional

CID.12

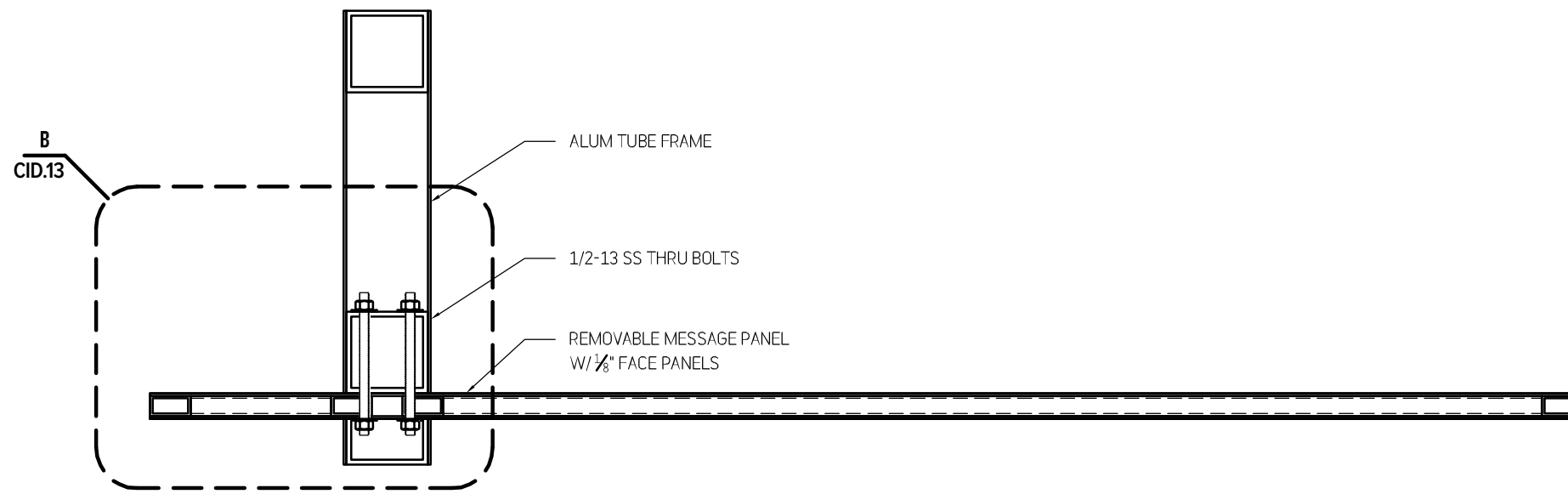

A SECTION
1 1/2" - 1'-0"

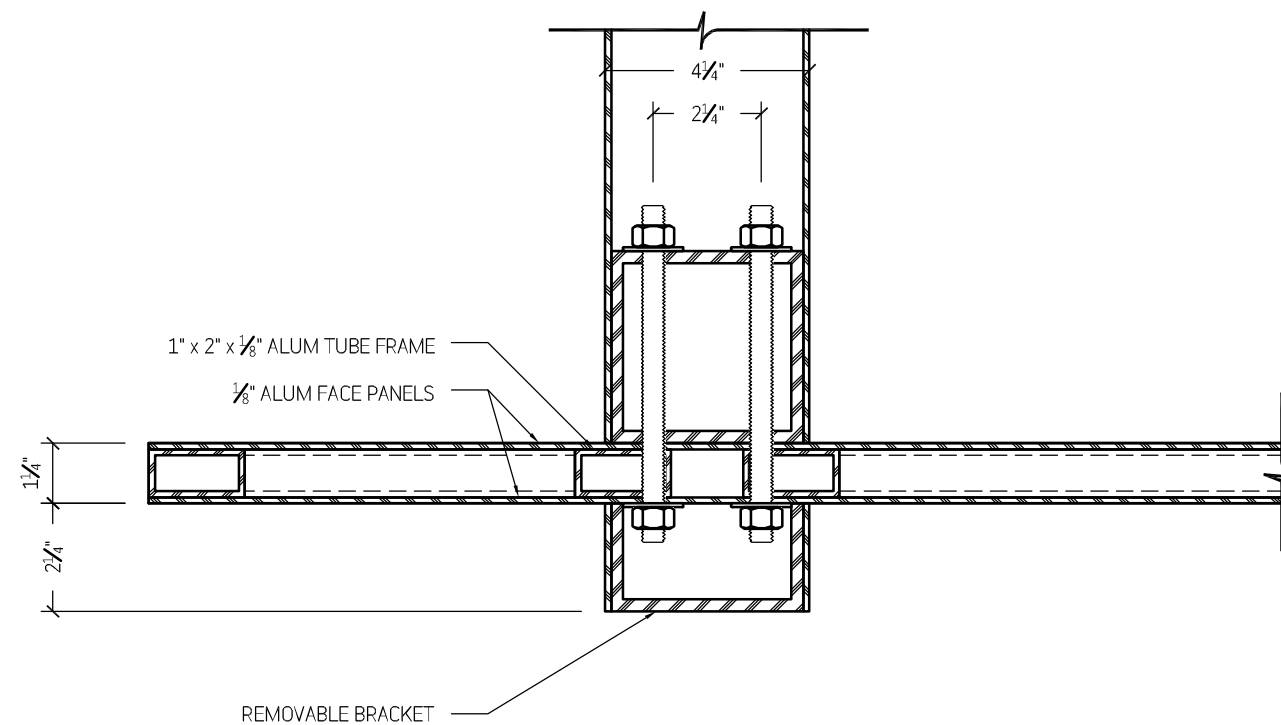

B SECTION
3" - 1'-0"

TWO TWELVE

902 BROADWAY
FLOOR 20
NEW YORK, NY
10010/6002
212 254/6670 T
212 254/6614 F

For Planning & Coordination Only –
Not for Construction

This document and the entirety of its contents are property of 212/Harakawa Inc. and/or Two Twelve Associates, Inc. No part of this document shall be duplicated, disseminated, distributed or used for any purpose without express written permission.

Do not use for final construction. Sign fabricator to verify and be responsible for all dimensions and work conditions and inform this office of variations prior to performing work. Written dimensions govern over scaled dimensions.

No.	Revisions
-----	-----------

Date 15 May 2017

Project No. UCONN-046

Phase CID

Project Title
University of Connecticut
Campus Wayfinding

Sign Type B1
Primary Vehicular
Directional

CID.13

TWO TWELVE

902 BROADWAY
 FLOOR 20
 NEW YORK, NY
 10010/6002
 212 254/6670 T
 212 254/6614 F

For Planning & Coordination Only –
 Not for Construction

This document and the entirety of its
 contents are property of 212/Harakawa
 Inc. and/or Two Twelve Associates, Inc.
 No part of this document shall be
 duplicated, disseminated, distributed
 or used for any purpose without
 express written permission.

Do not use for final construction. Sign
 fabricator to verify and be responsible
 for all dimensions and work conditions
 and inform this office of variations prior
 to performing work. Written dimensions
 govern over scaled dimensions.

No.	Revisions

Date 15 May 2017

Project No. UCONN-046

Phase CID

Project Title
 University of Connecticut
 Campus Wayfinding

Sign Type B1
Primary Vehicular
Directional

CID.14

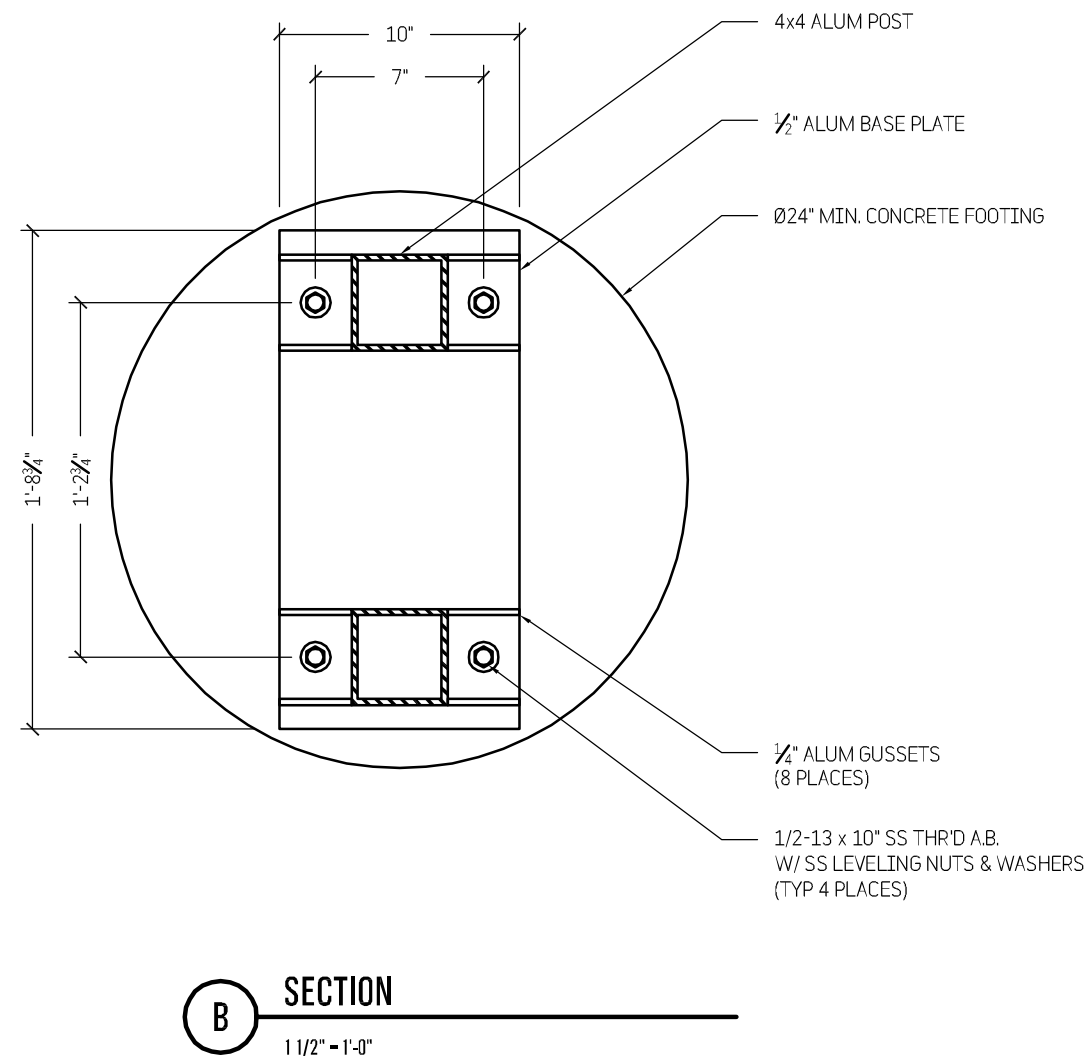
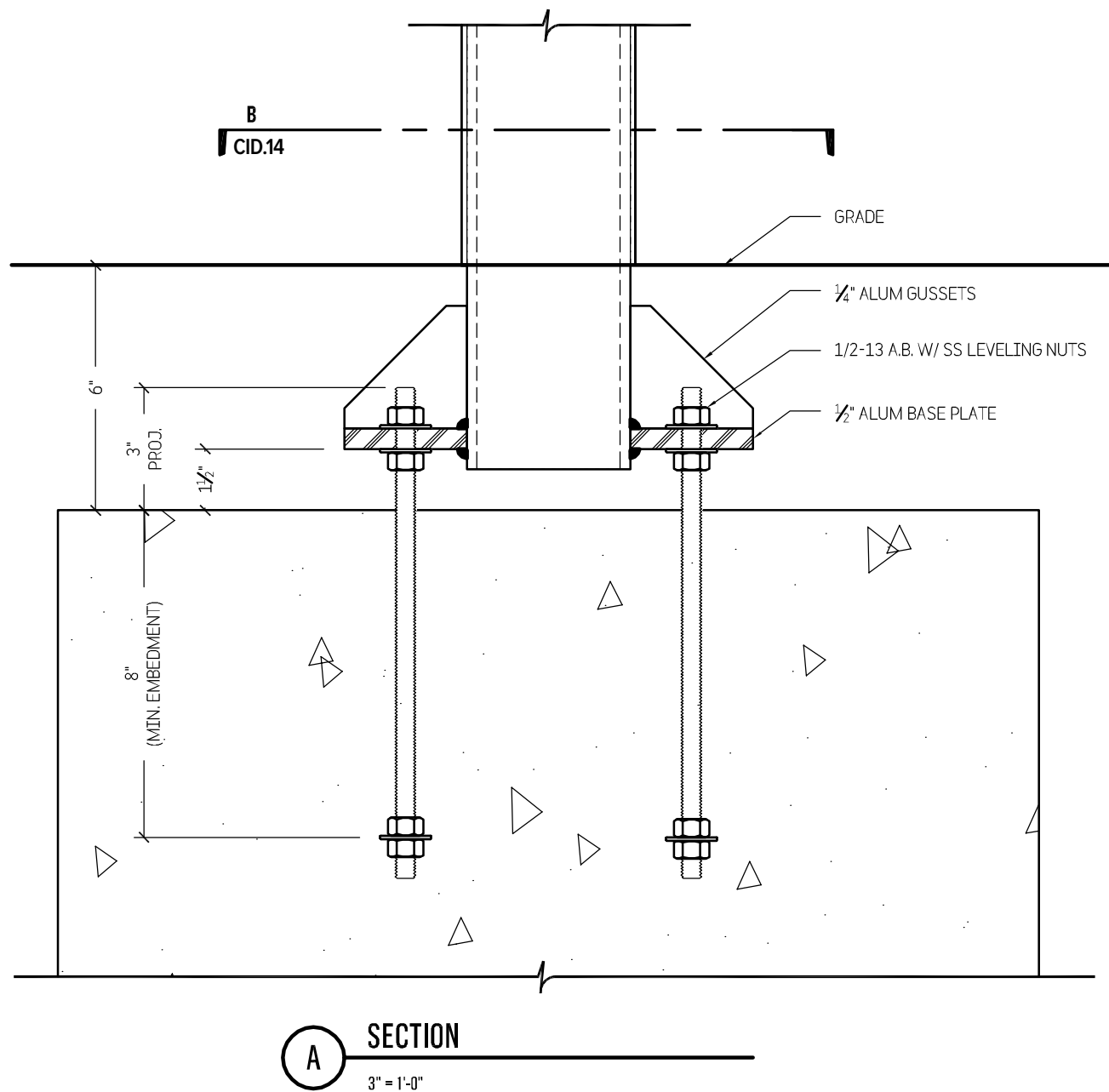

B SECTION
 1 1/2" = 1'-0"

A SECTION
 3" = 1'-0"

Double-sided variation is permissible on a case-by-case basis upon request to the University's Representative.

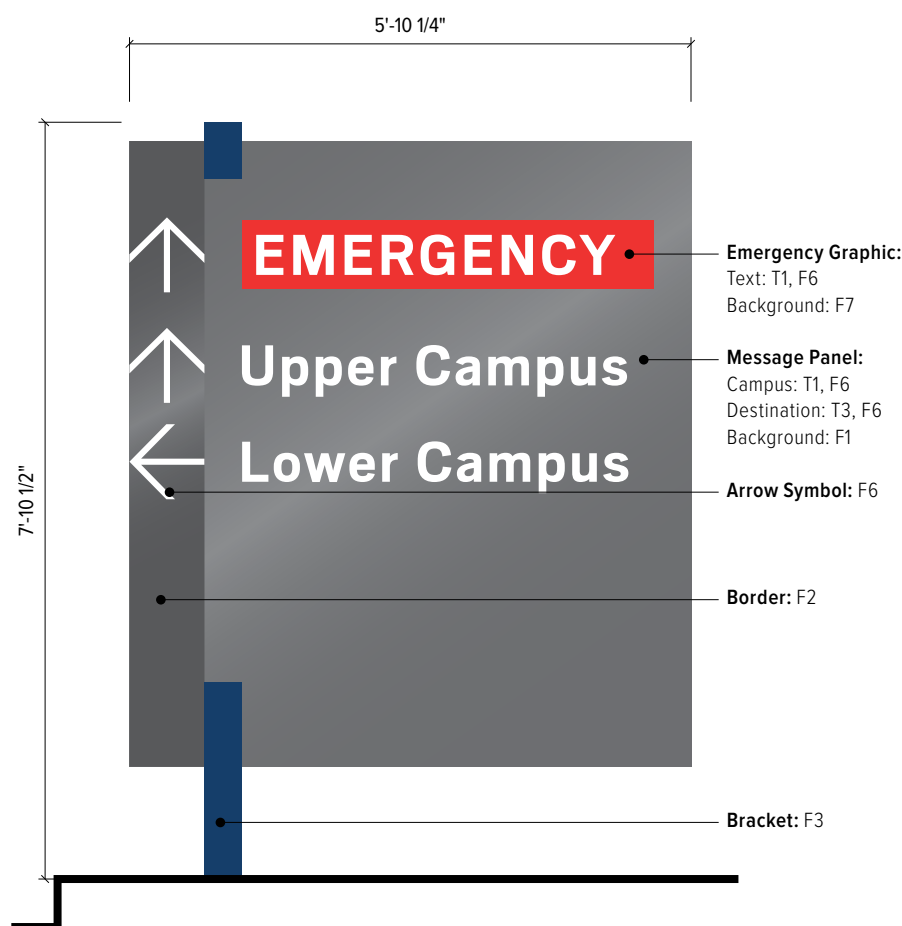

1 Elevation - Sign Type B2
1/2" = 1'-0"

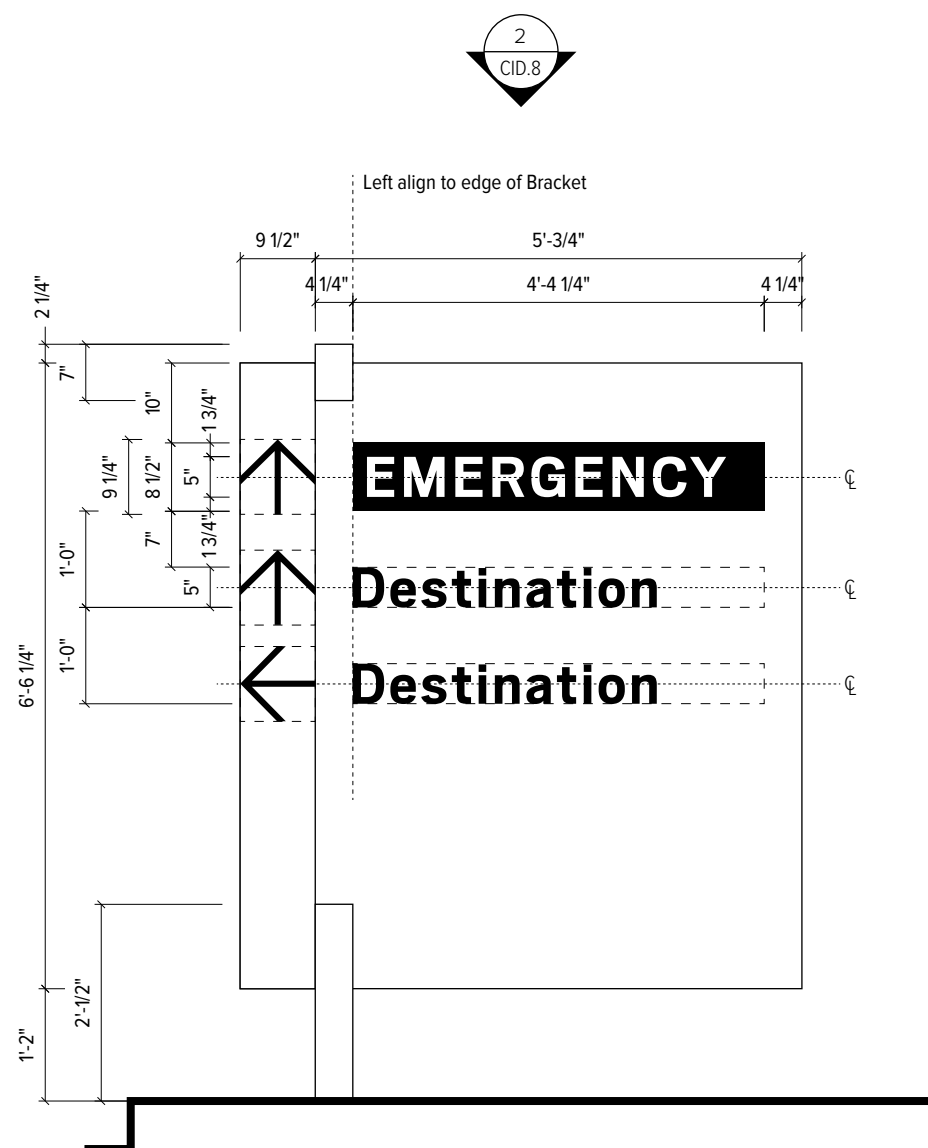

2 Graphic Layout - Sign Type B2
1/2" = 1'-0"

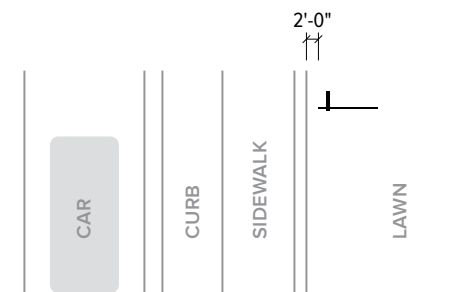

3 Installation Plan - Sign Type B2 (Typical)
NTS

NOTE: Sign orientation to be determined by University Representative

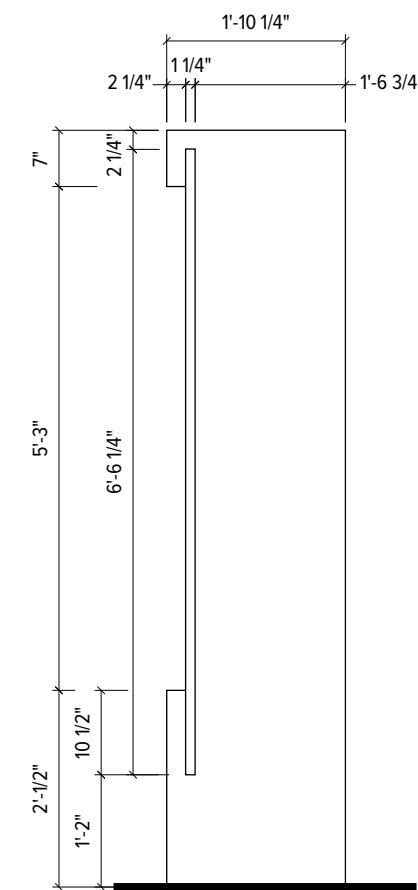

4 Side View - Sign Type B2
1/2" = 1'-0"

TWO TWELVE

902 BROADWAY
FLOOR 20
NEW YORK, NY
10010/6002
212 254/6670 T
212 254/6614 F

For Planning & Coordination Only –
Not for Construction

This document and the entirety of its contents are property of 212/Harakawa Inc. and/or Two Twelve Associates, Inc. No part of this document shall be duplicated, disseminated, distributed or used for any purpose without express written permission.

Do not use for final construction. Sign fabricator to verify and be responsible for all dimensions and work conditions and inform this office of variations prior to performing work. Written dimensions govern over scaled dimensions.

No. Revisions

Date 15 May 2017
Project No. UCONN-046
Phase CID
Project Title
University of Connecticut
Campus Wayfinding

Sign Type B2
Secondary Vehicular
Directional

CID.15

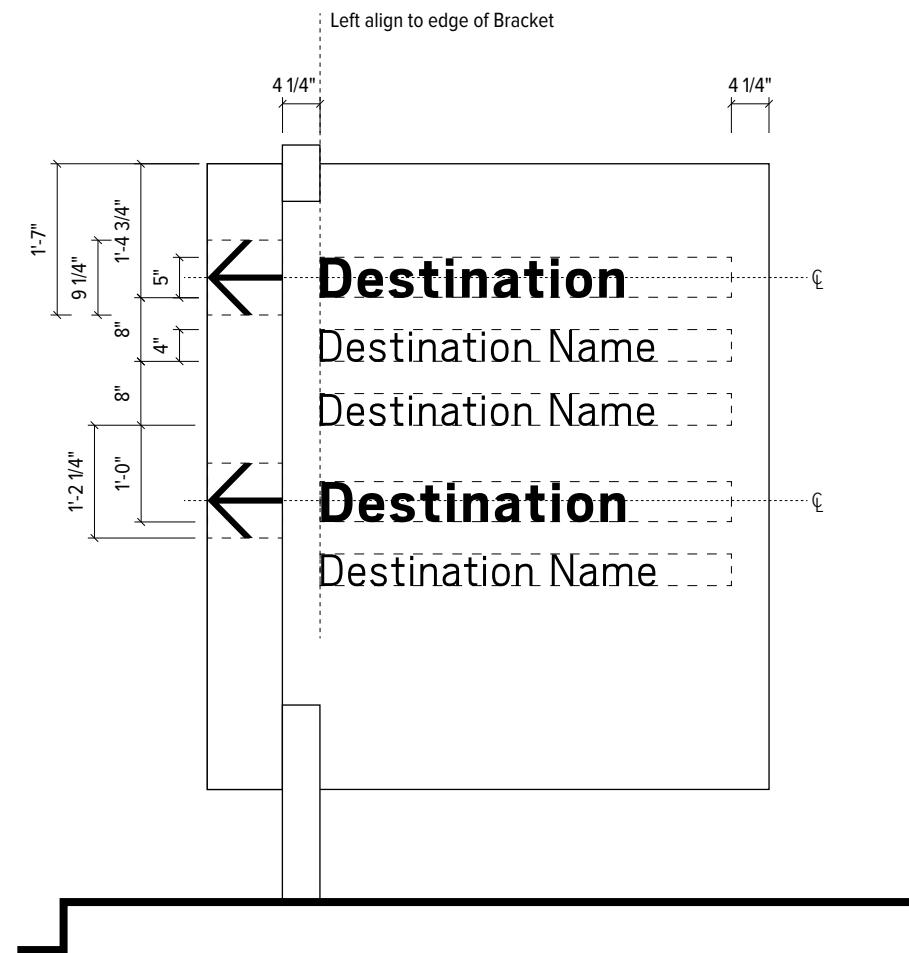

1 Alternate Graphic Layout - Sign Type B2
1/2" = 1'-0"

TWO TWELVE

902 BROADWAY
FLOOR 20
NEW YORK, NY
10010/6002
212 254/6670 T
212 254/6614 F

For Planning & Coordination Only –
Not for Construction

This document and the entirety of its contents are property of 212/Harakawa Inc. and/or Two Twelve Associates, Inc. No part of this document shall be duplicated, disseminated, distributed or used for any purpose without express written permission.

Do not use for final construction. Sign fabricator to verify and be responsible for all dimensions and work conditions and inform this office of variations prior to performing work. Written dimensions govern over scaled dimensions.

No.	Revisions

Date 15 May 2017

Project No. UCONN-046

Phase CID

Project Title

University of Connecticut
Campus Wayfinding

Sign Type B2
Secondary Vehicular
Directional

CID.16

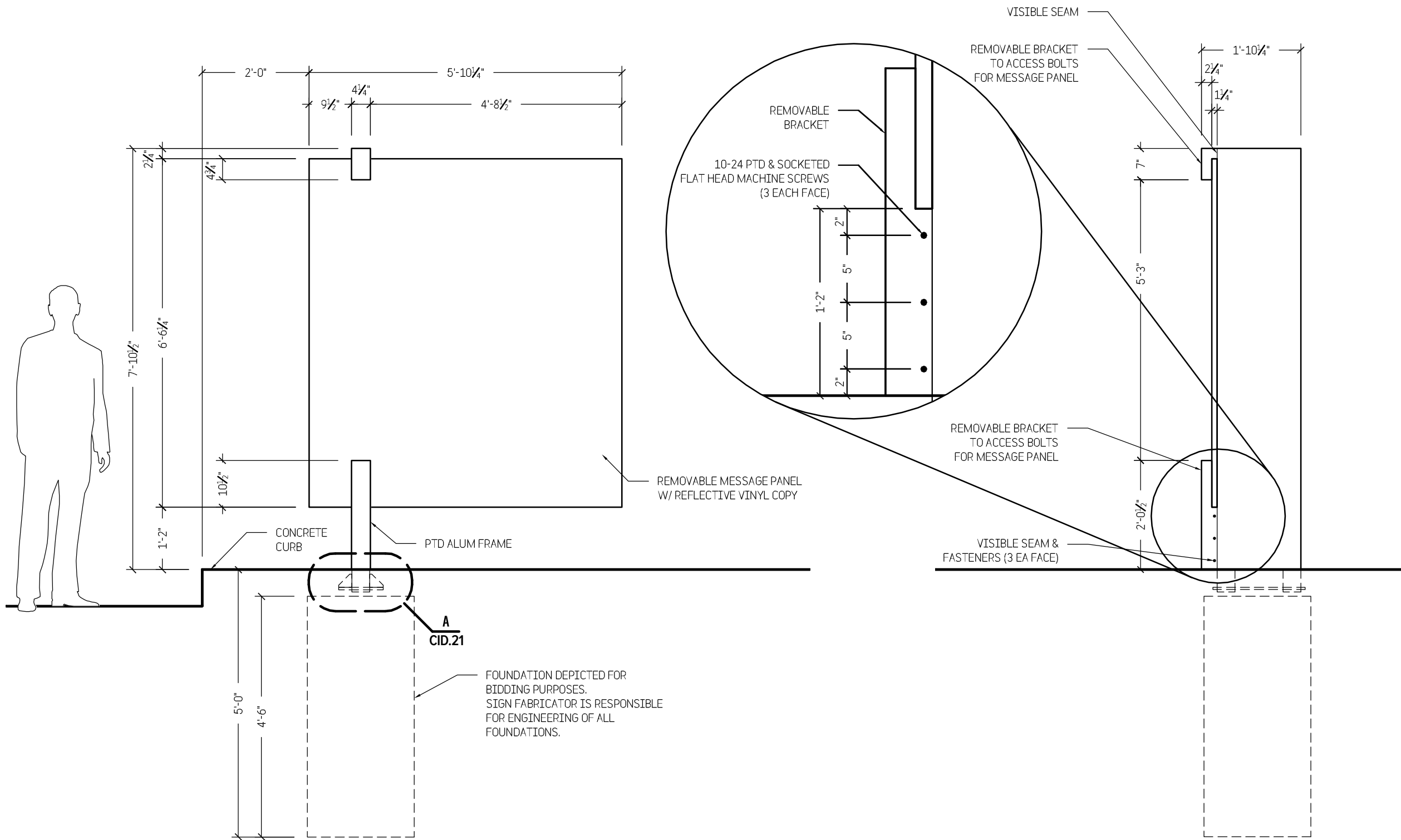

1 ELEVATION
1/2" = 1'-0"

2 SIDE VIEW
1/2" = 1'-0"

TWO TWELVE

902 BROADWAY
FLOOR 20
NEW YORK, NY
10010/6002
212 254/6670 T
212 254/6614 F

For Planning & Coordination Only –
Not for Construction

This document and the entirety of its
contents are property of 212/Harakawa
Inc. and/or Two Twelve Associates, Inc.
No part of this document shall be
duplicated, disseminated, distributed
or used for any purpose without
express written permission.

Do not use for final construction. Sign
fabricator to verify and be responsible
for all dimensions and work conditions
and inform this office of variations prior
to performing work. Written dimensions
govern over scaled dimensions.

No.	Revisions
-----	-----------

Date 15 May 2017

Project No. UCONN-046

Phase CID

Project Title
University of Connecticut
Campus Wayfinding

Sign Type B2
Secondary Vehicular
Directional

CID.17

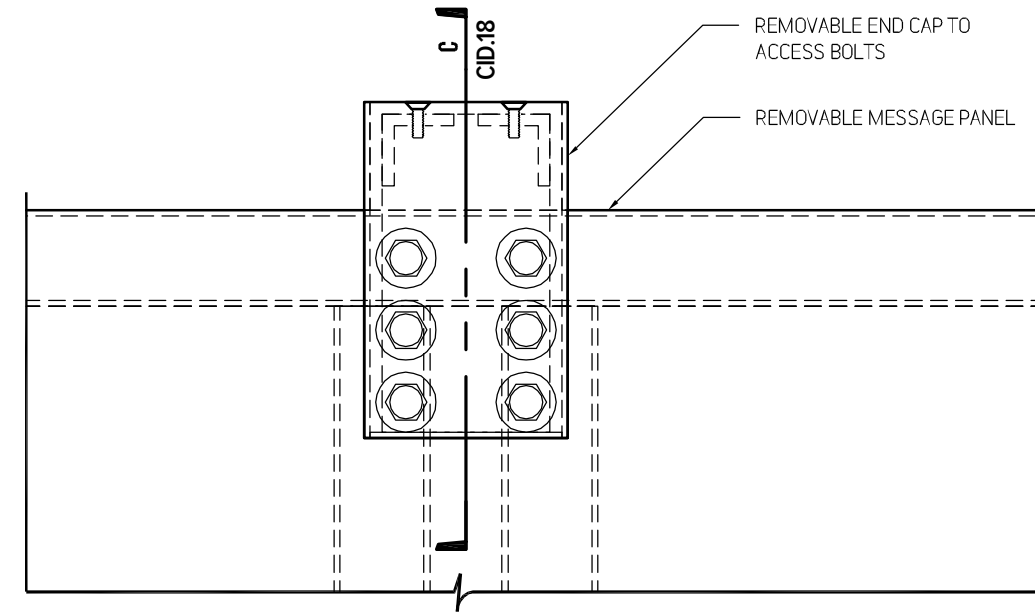
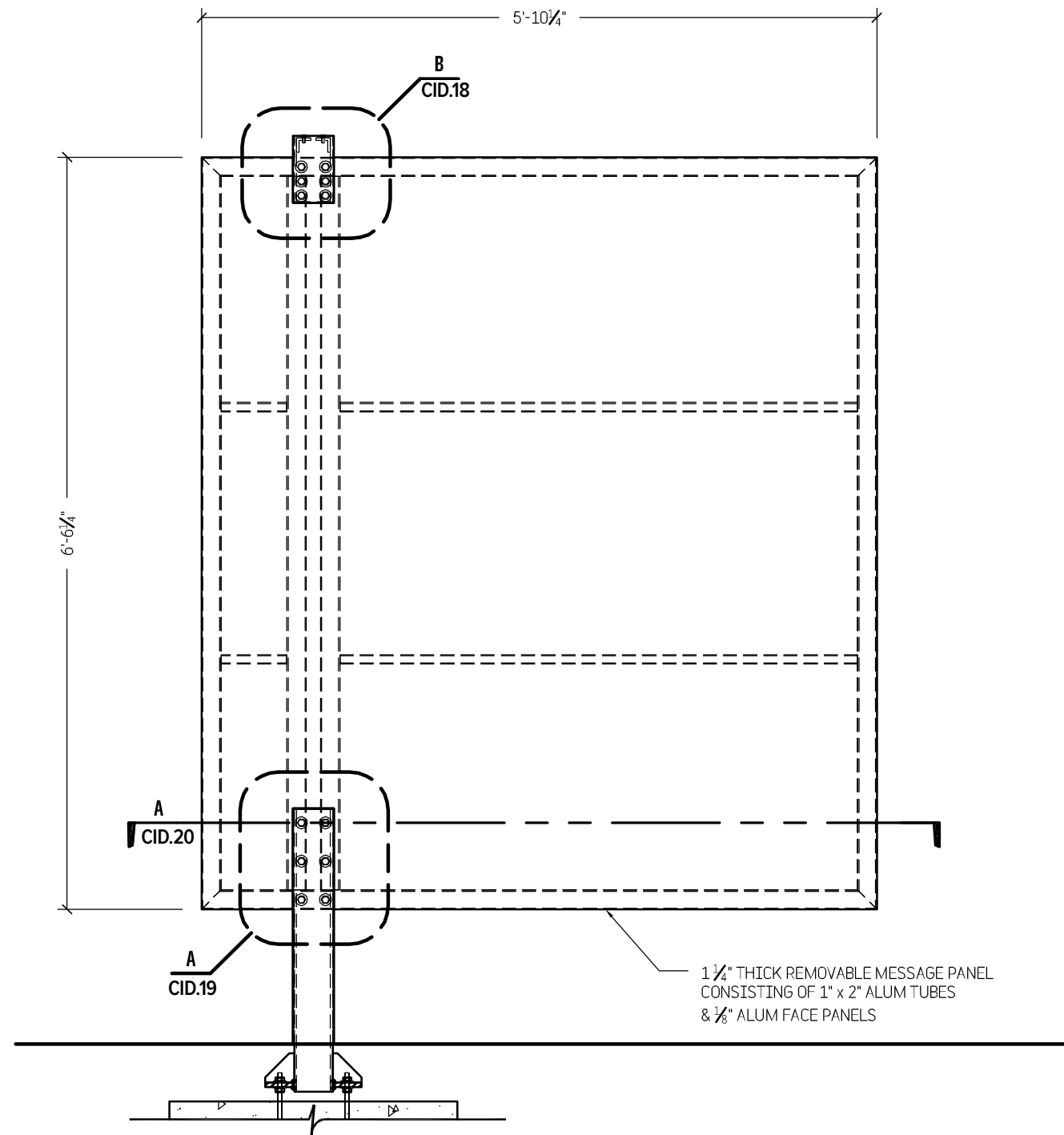

B SECTION
3" = 1'-0"

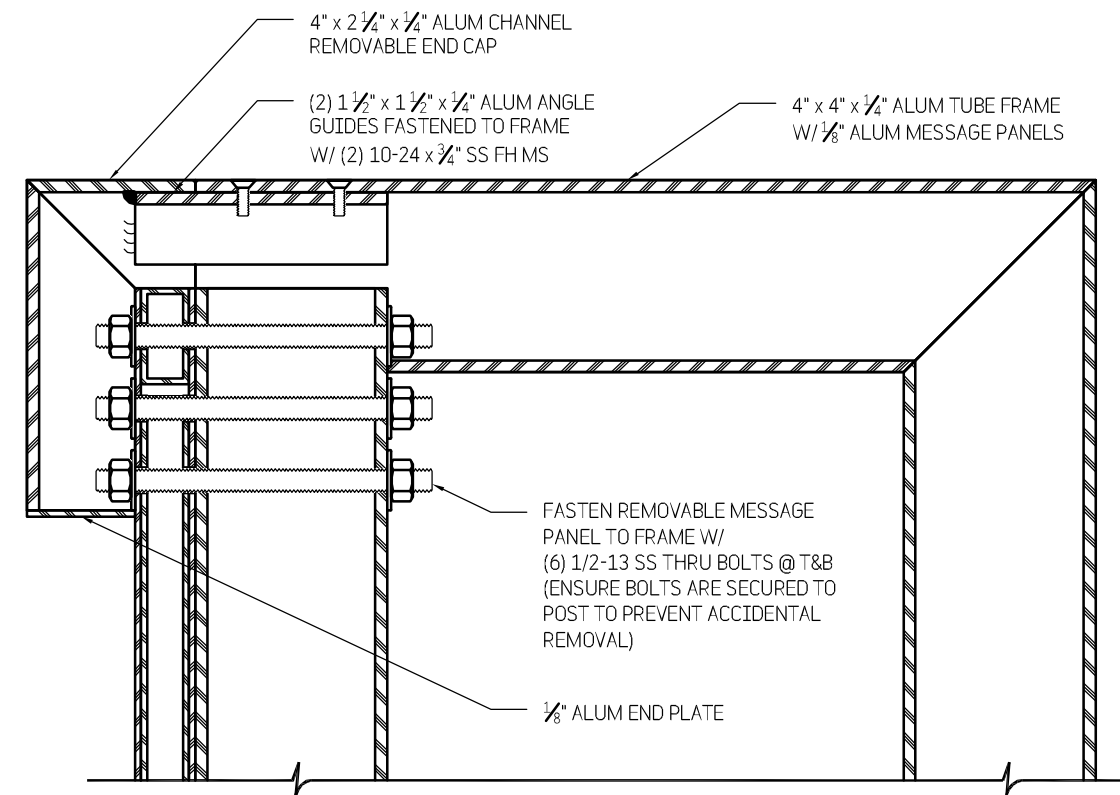

C SECTION
3" = 1'-0"

TWO TWELVE

902 BROADWAY
FLOOR 20
NEW YORK, NY
10010/6002
212 254/6670 T
212 254/6614 F

For Planning & Coordination Only –
Not for Construction

This document and the entirety of its
contents are property of 212/Harakawa
Inc. and/or Two Twelve Associates, Inc.
No part of this document shall be
duplicated, disseminated, distributed
or used for any purpose without
express written permission.

Do not use for final construction. Sign
fabricator to verify and be responsible
for all dimensions and work conditions
and inform this office of variations prior
to performing work. Written dimensions
govern over scaled dimensions.

No.	Revisions

Date 15 May 2017

Project No. UCONN-046

Phase CID

Project Title

University of Connecticut
Campus Wayfinding

Sign Type B2
Secondary Vehicular
Directional

CID.18

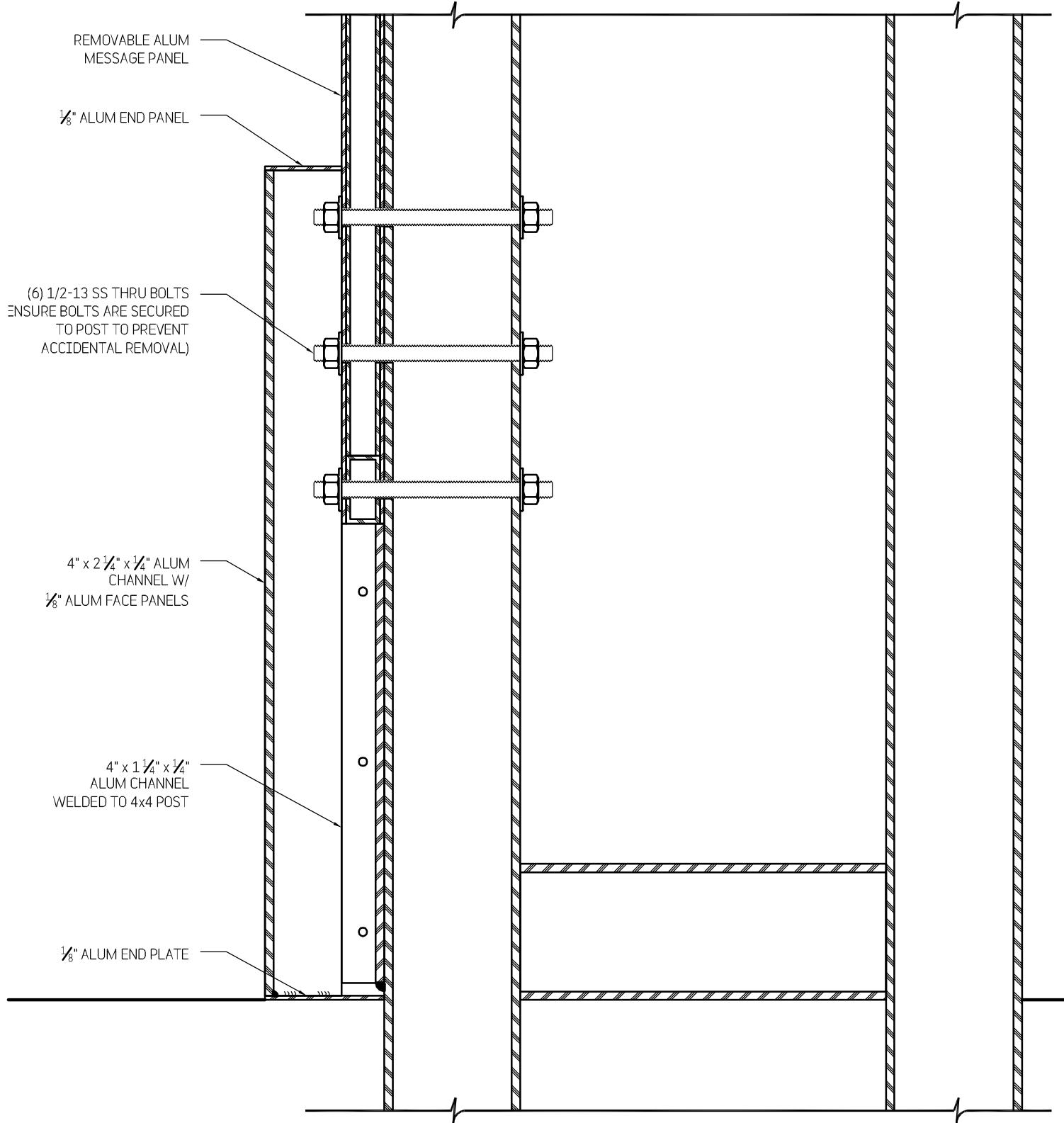
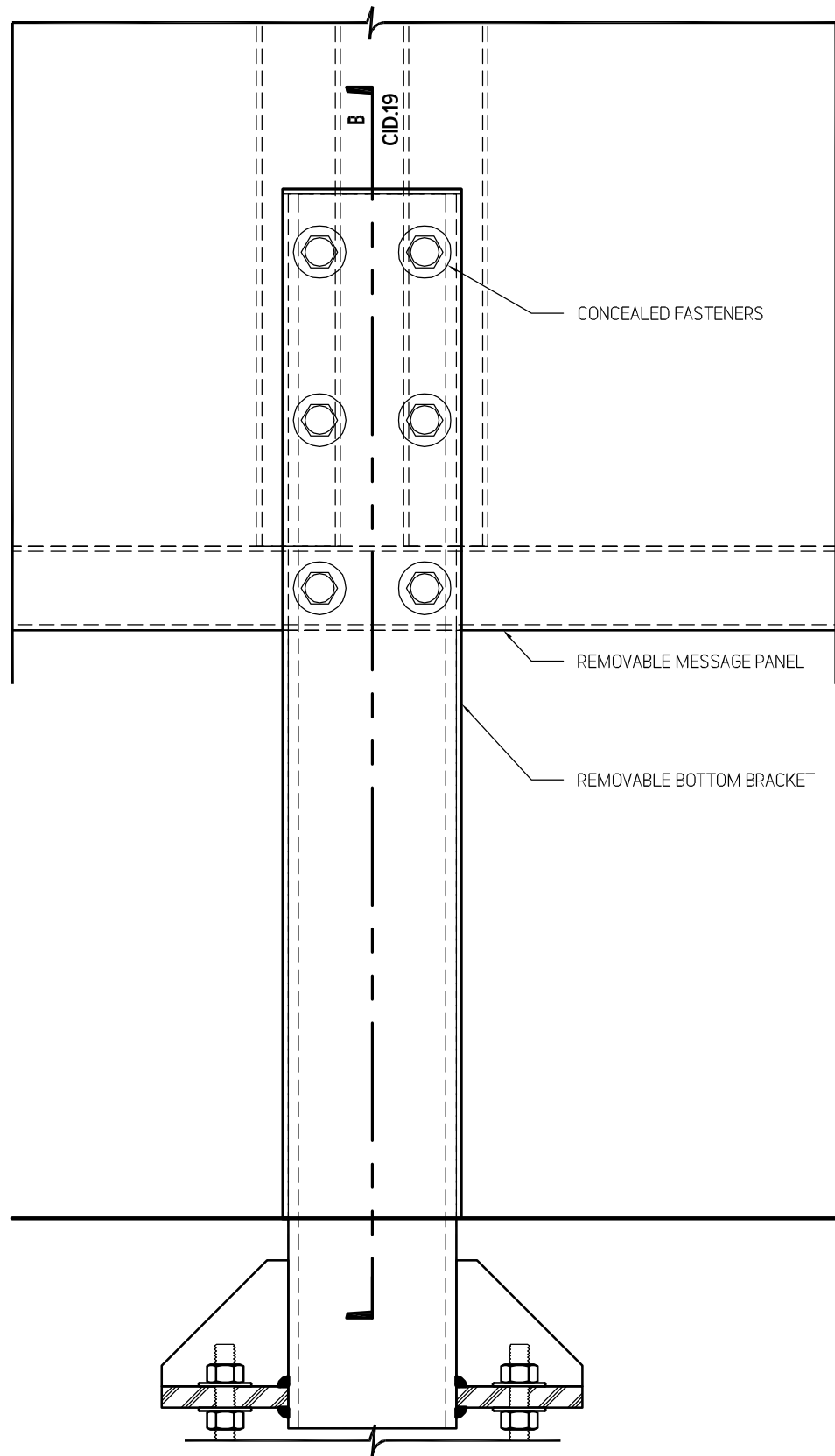

TWO TWELVE

902 BROADWAY
 FLOOR 20
 NEW YORK, NY
 10010/6002
 212 254/6670 T
 212 254/6614 F

For Planning & Coordination Only –
 Not for Construction

This document and the entirety of its contents are property of 212/Harakawa Inc. and/or Two Twelve Associates, Inc. No part of this document shall be duplicated, disseminated, distributed or used for any purpose without express written permission.

Do not use for final construction. Sign fabricator to verify and be responsible for all dimensions and work conditions and inform this office of variations prior to performing work. Written dimensions govern over scaled dimensions.

No.	Revisions

Date 15 May 2017

Project No. UCONN-046

Phase CID

Project Title
 University of Connecticut
 Campus Wayfinding

Sign Type B2
Secondary Vehicular
Directional

CID.19

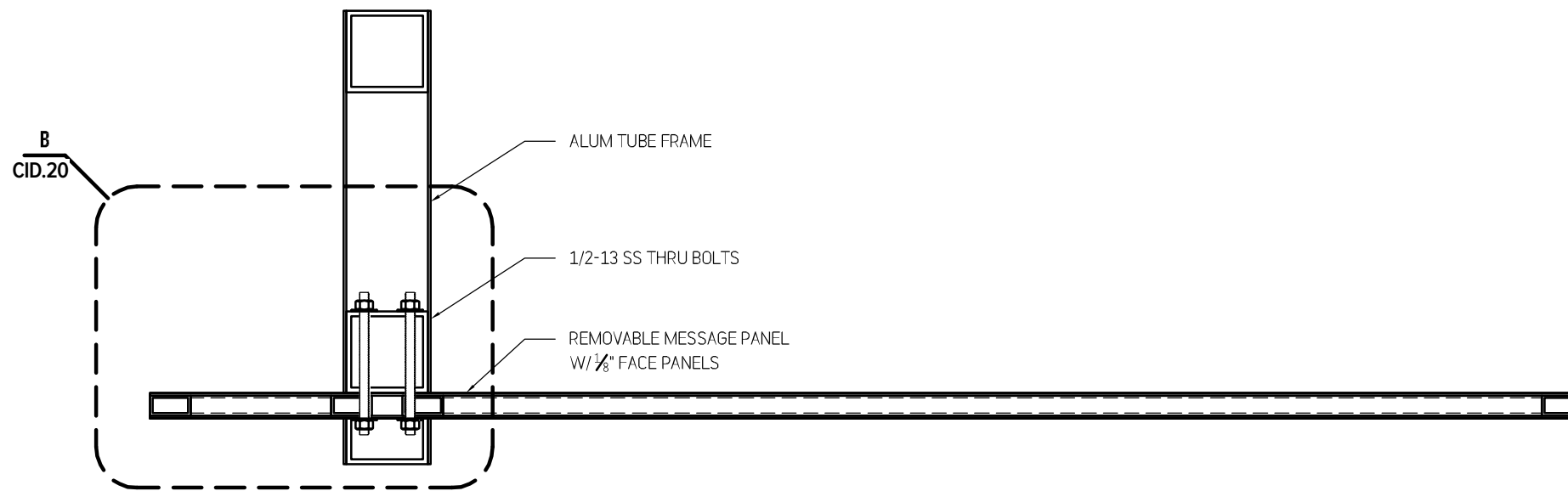

A SECTION
1 1/2" - 1'-0"

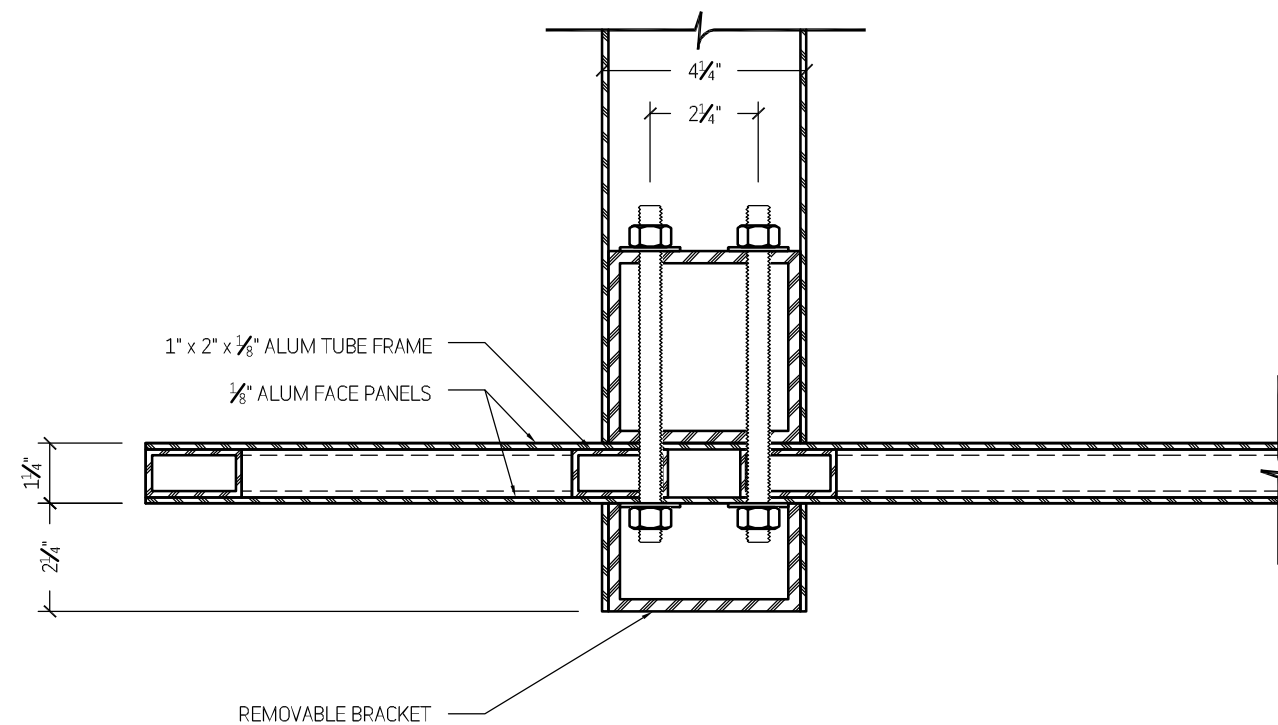

B SECTION
3" - 1'-0"

TWO TWELVE

902 BROADWAY
FLOOR 20
NEW YORK, NY
10010/6002
212 254/6670 T
212 254/6614 F

For Planning & Coordination Only –
Not for Construction

This document and the entirety of its contents are property of 212/Harakawa Inc. and/or Two Twelve Associates, Inc. No part of this document shall be duplicated, disseminated, distributed or used for any purpose without express written permission.

Do not use for final construction. Sign fabricator to verify and be responsible for all dimensions and work conditions and inform this office of variations prior to performing work. Written dimensions govern over scaled dimensions.

No.	Revisions
-----	-----------

Date 15 May 2017

Project No. UCONN-046

Phase CID

Project Title
University of Connecticut
Campus Wayfinding

Sign Type B2
Secondary Vehicular
Directional

CID.20

TWO TWELVE

902 BROADWAY
 FLOOR 20
 NEW YORK, NY
 10010/6002
 212 254/6670 T
 212 254/6614 F

For Planning & Coordination Only –
 Not for Construction

This document and the entirety of its contents are property of 212/Harakawa Inc. and/or Two Twelve Associates, Inc. No part of this document shall be duplicated, disseminated, distributed or used for any purpose without express written permission.

Do not use for final construction. Sign fabricator to verify and be responsible for all dimensions and work conditions and inform this office of variations prior to performing work. Written dimensions govern over scaled dimensions.

No.	Revisions

Date 15 May 2017

Project No. UCONN-046

Phase CID

Project Title
 University of Connecticut
 Campus Wayfinding

Sign Type B2
 Secondary Vehicular
 Directional

CID.21

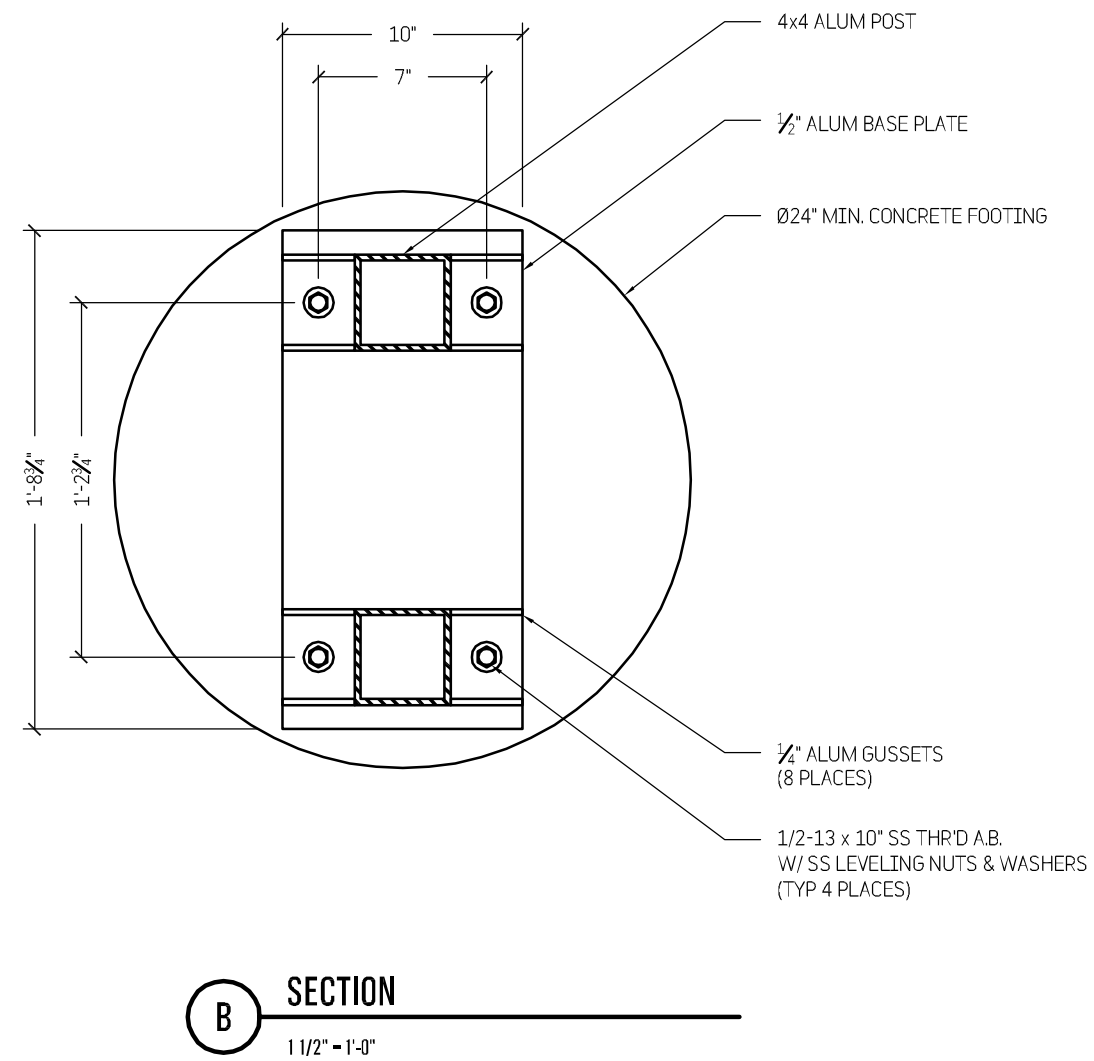
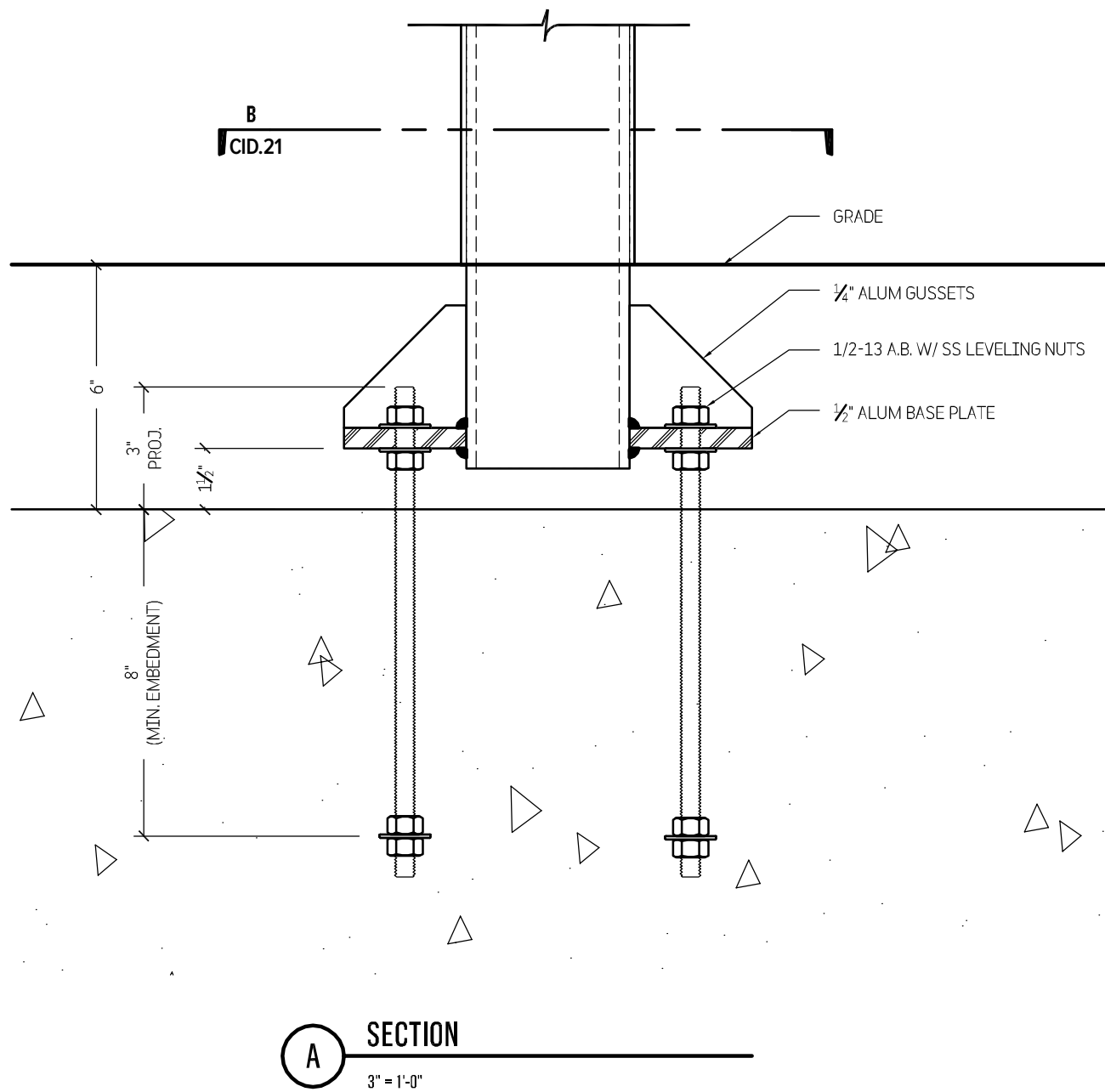

Double-sided variation is permissible on a case-by-case basis upon request to the University's Representative.

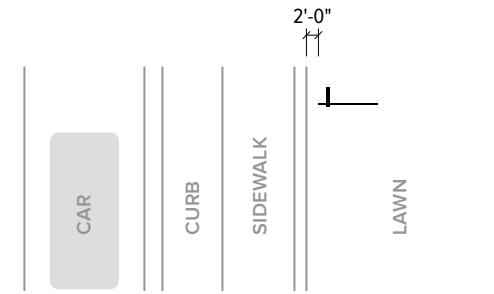

3 Installation Plan - Sign Type B3 (Typical)
NTS

NOTE: Sign orientation to be determined by University Representative

TWO TWELVE

902 BROADWAY
FLOOR 20
NEW YORK, NY
10010/6002
212 254/6670 T
212 254/6614 F

For Planning & Coordination Only –
Not for Construction

This document and the entirety of its contents are property of 212/Harakawa Inc. and/or Two Twelve Associates, Inc. No part of this document shall be duplicated, disseminated, distributed or used for any purpose without express written permission.

Do not use for final construction. Sign fabricator to verify and be responsible for all dimensions and work conditions and inform this office of variations prior to performing work. Written dimensions govern over scaled dimensions.

No.	Revisions

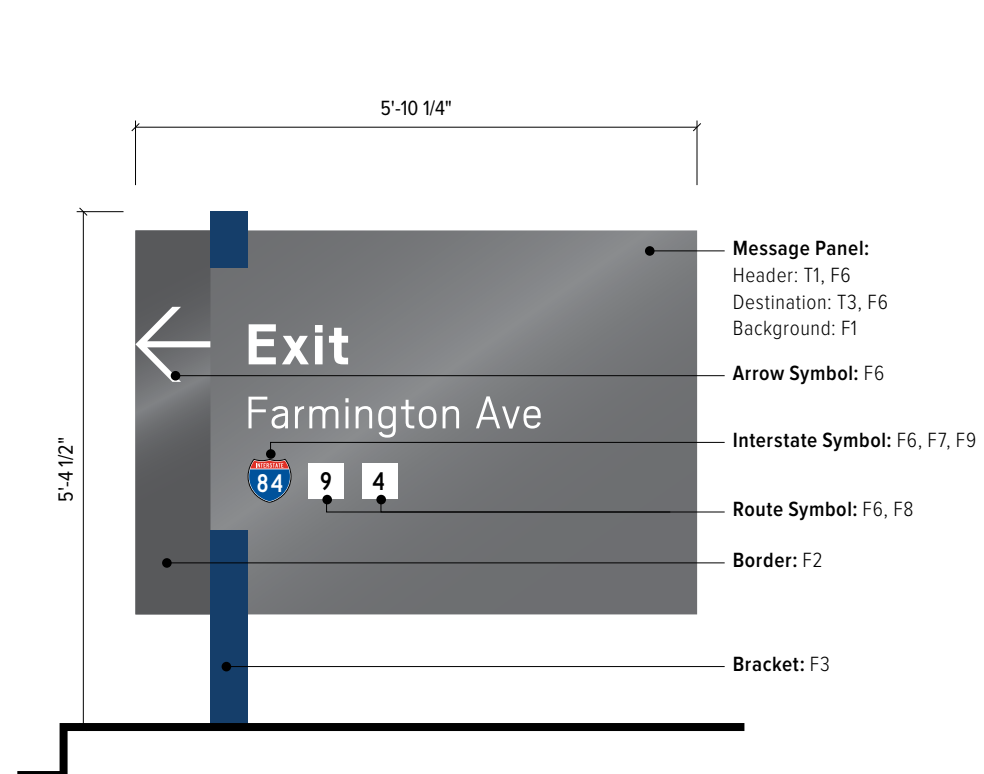

1 Elevation - Sign Type B3
1/2" = 1'-0"

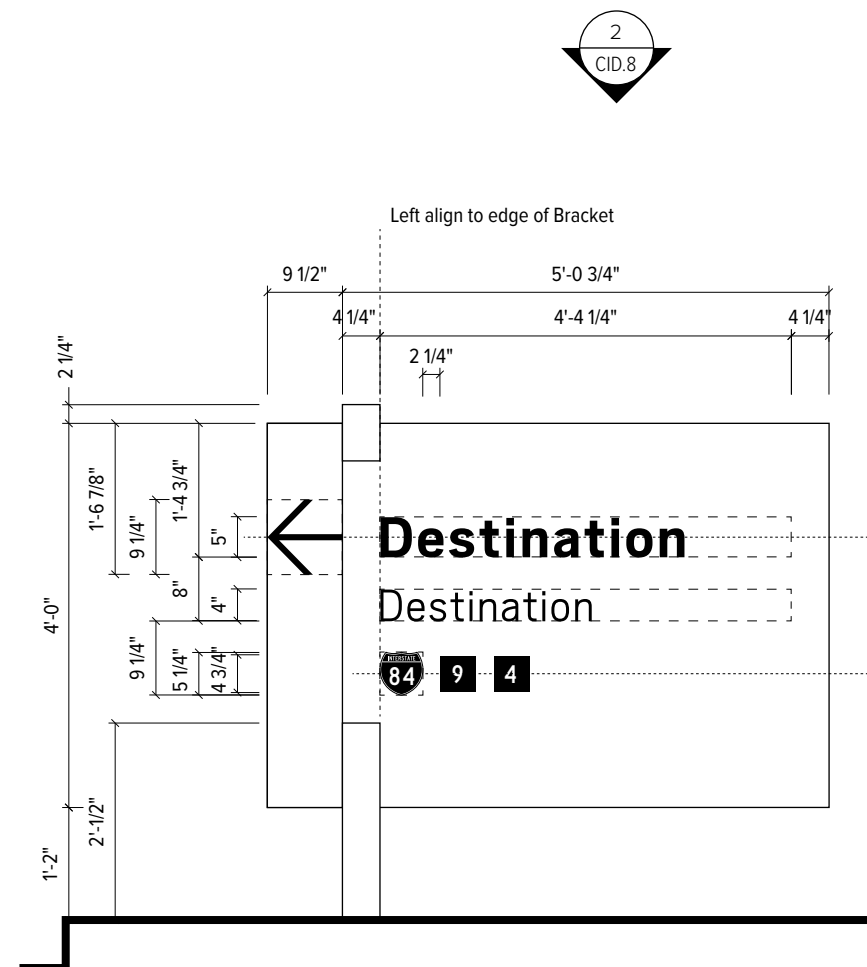

2 Graphic Layout - Sign Type B3
1/2" = 1'-0"

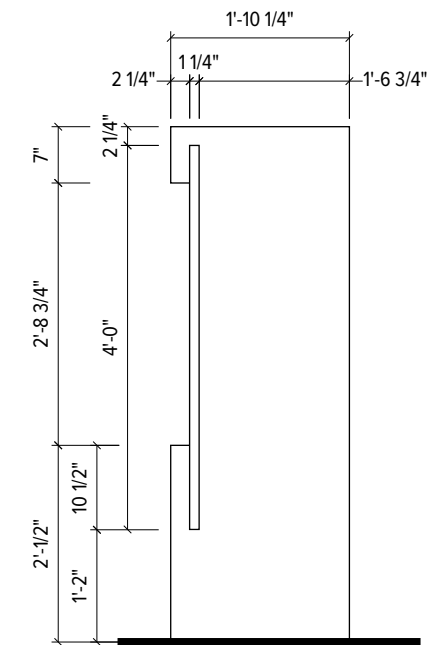

4 Side View - Sign Type B3
1/2" = 1'-0"

Date	15 May 2017
Project No.	UCONN-046
Phase	CID
Project Title	University of Connecticut Campus Wayfinding

Sign Type B3
Tertiary Vehicular
Directional

CID.22

TWO TWELVE

902 BROADWAY
 FLOOR 20
 NEW YORK, NY
 10010/6002
 212 254/6670 T
 212 254/6614 F

For Planning & Coordination Only –
 Not for Construction

This document and the entirety of its contents are property of 212/Harakawa Inc. and/or Two Twelve Associates, Inc. No part of this document shall be duplicated, disseminated, distributed or used for any purpose without express written permission.

Do not use for final construction. Sign fabricator to verify and be responsible for all dimensions and work conditions and inform this office of variations prior to performing work. Written dimensions govern over scaled dimensions.

No.	Revisions

Date 15 May 2017

Project No. UCONN-046

Phase CID

Project Title

University of Connecticut
 Campus Wayfinding

Sign Type B3
Tertiary Vehicular
Directional

CID.23

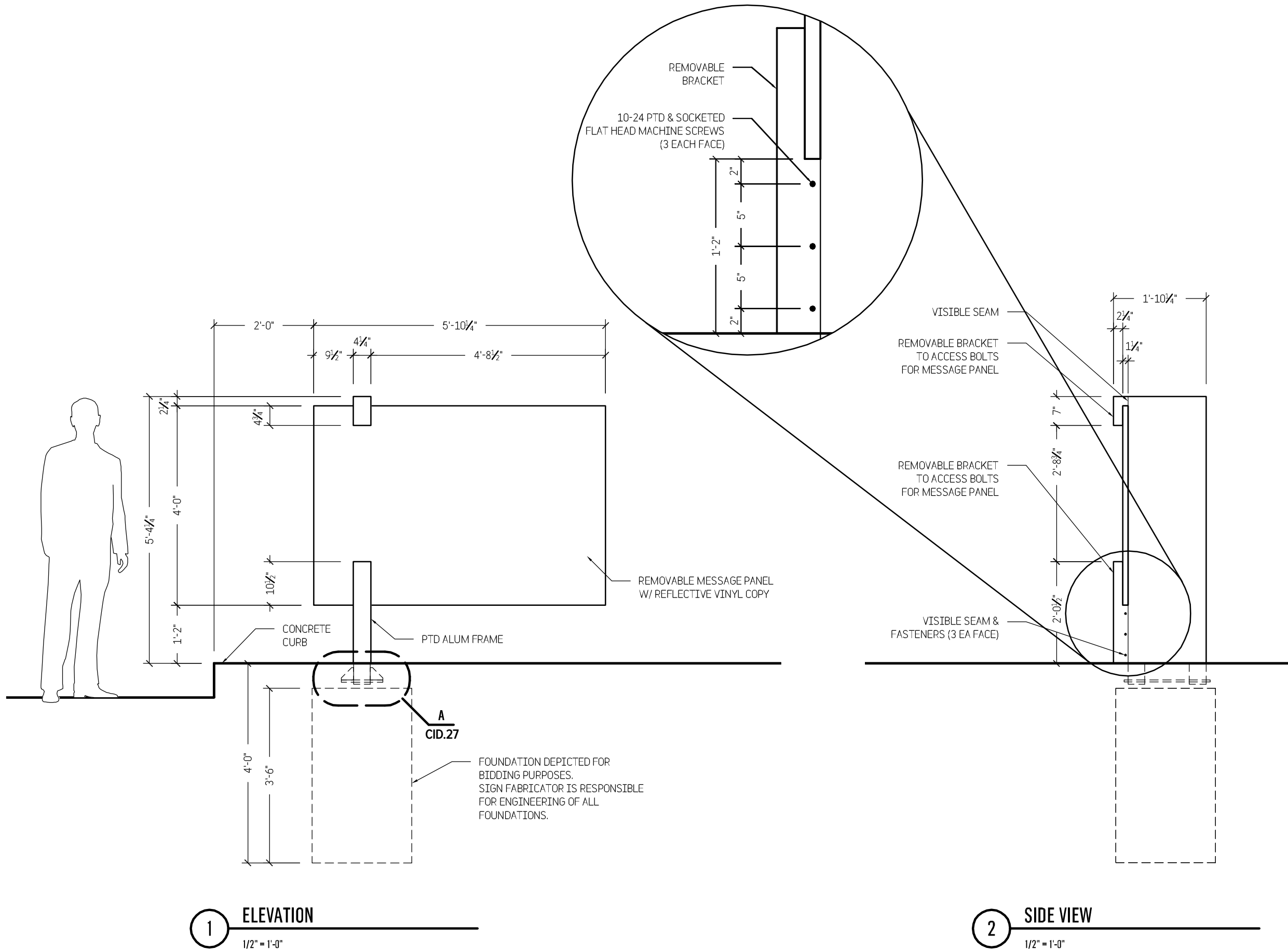

1 ELEVATION
 1/2" = 1'-0"

2 SIDE VIEW
 1/2" = 1'-0"

TWO TWELVE

902 BROADWAY
 FLOOR 20
 NEW YORK, NY
 10010/6002
 212 254/6670 T
 212 254/6614 F

For Planning & Coordination Only –
 Not for Construction

This document and the entirety of its
 contents are property of 212/Harakawa
 Inc. and/or Two Twelve Associates, Inc.
 No part of this document shall be
 duplicated, disseminated, distributed
 or used for any purpose without
 express written permission.

Do not use for final construction. Sign
 fabricator to verify and be responsible
 for all dimensions and work conditions
 and inform this office of variations prior
 to performing work. Written dimensions
 govern over scaled dimensions.

No.	Revisions

Date 15 May 2017

Project No. UCONN-046

Phase CID

Project Title
 University of Connecticut
 Campus Wayfinding

Sign Type B3
Tertiary Vehicular
Directional

CID.24

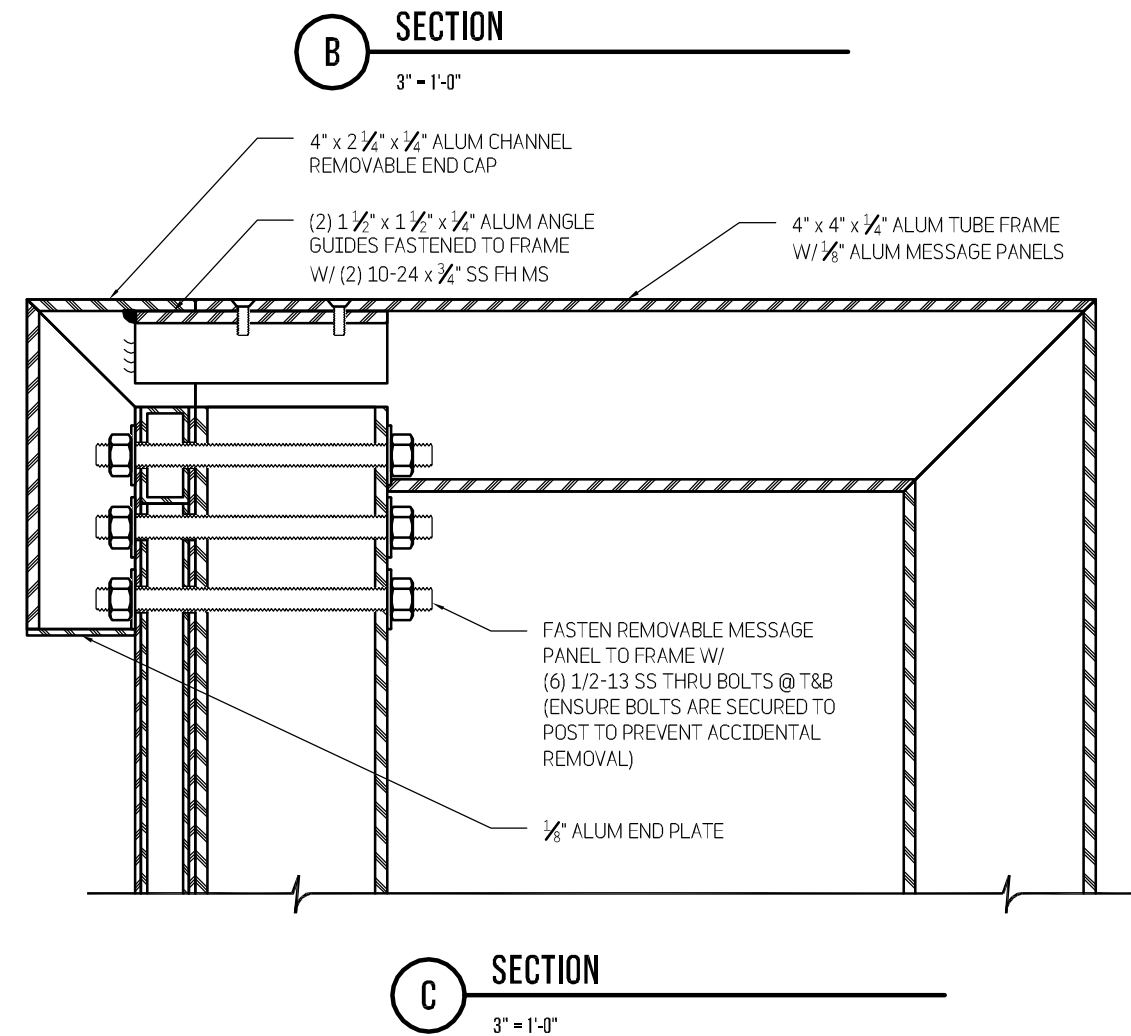
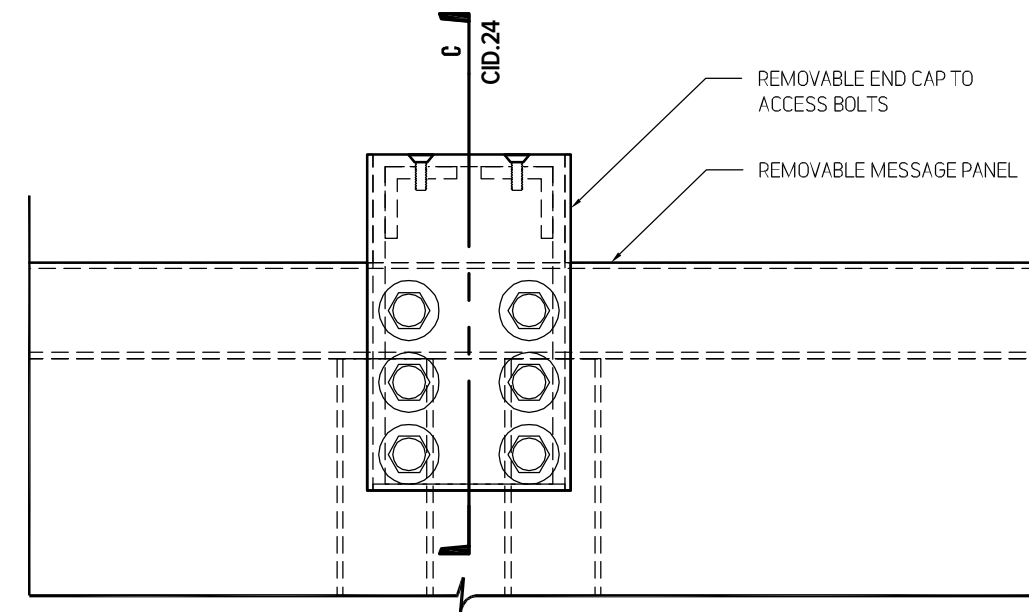
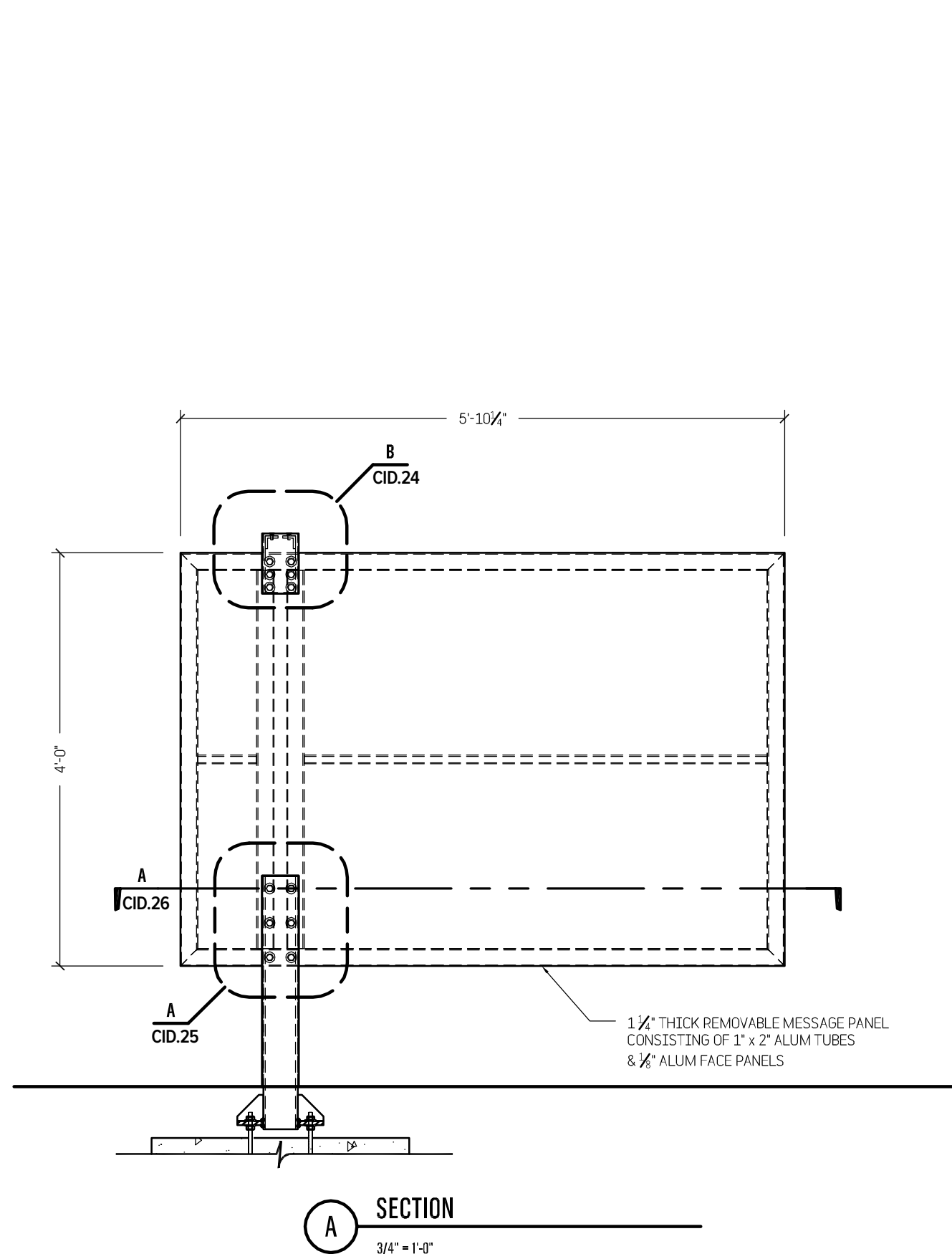

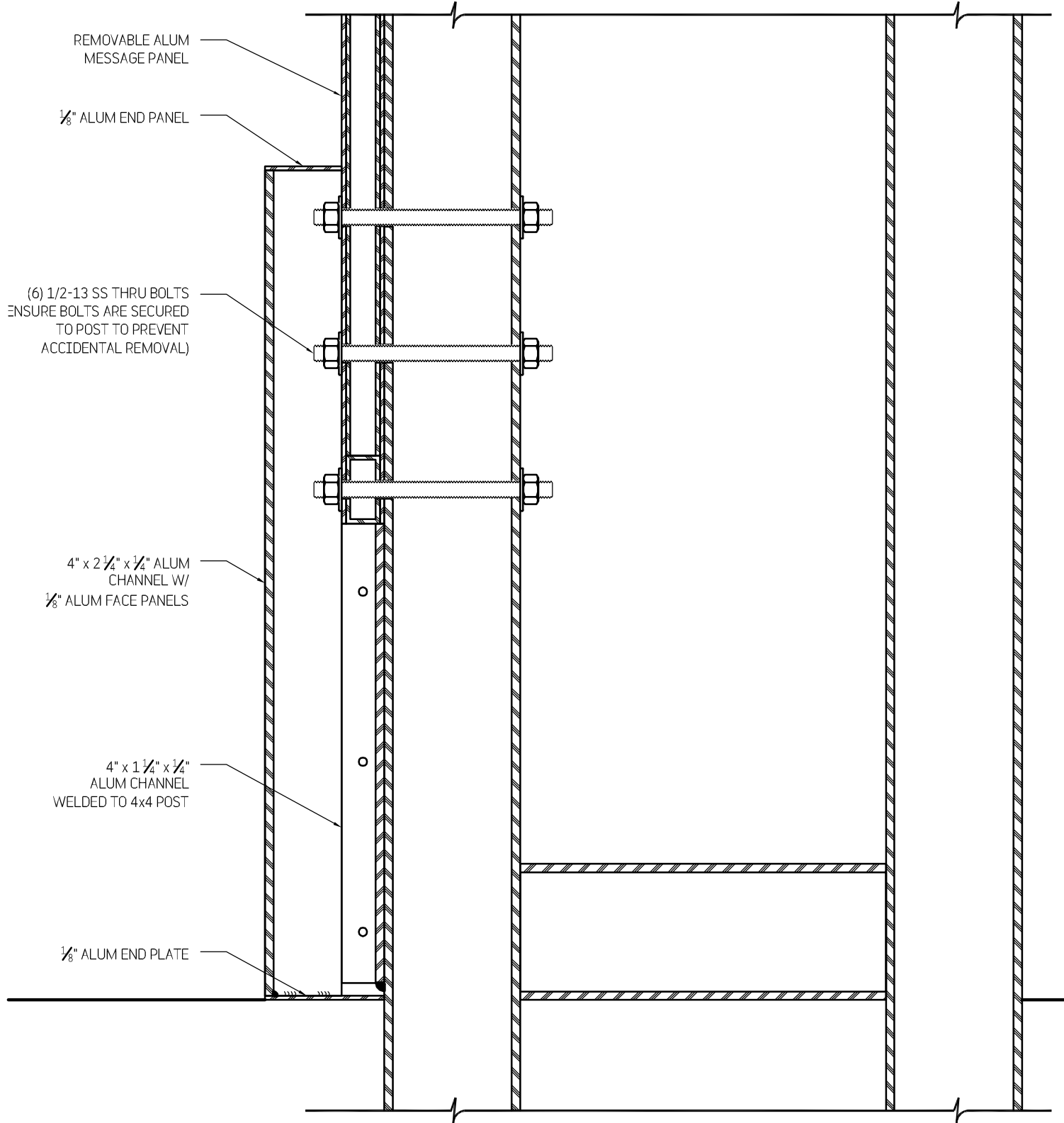
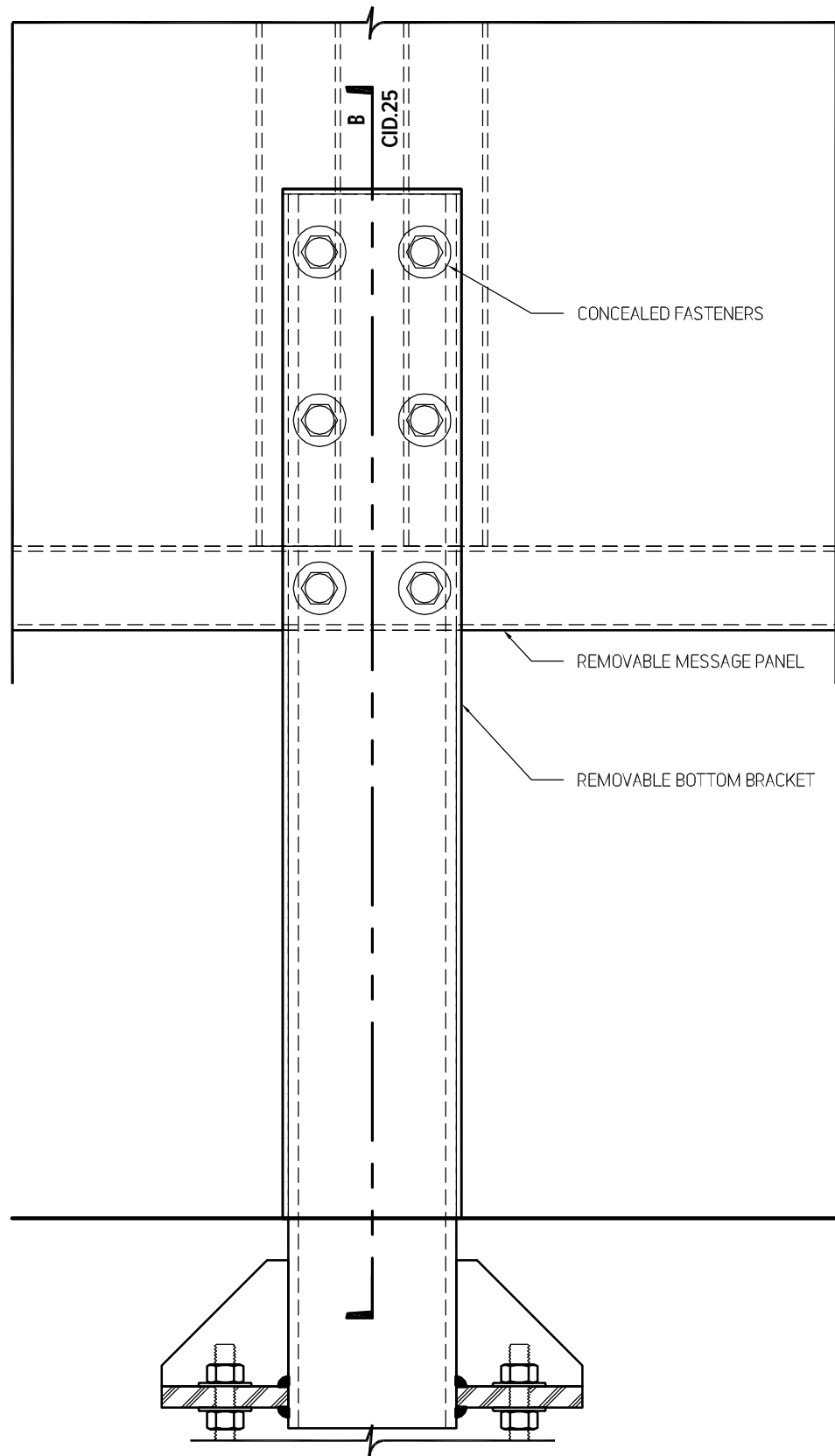

TWO TWELVE

902 BROADWAY
 FLOOR 20
 NEW YORK, NY
 10010/6002
 212 254/6670 T
 212 254/6614 F

For Planning & Coordination Only –
 Not for Construction

This document and the entirety of its contents are property of 212/Harakawa Inc. and/or Two Twelve Associates, Inc. No part of this document shall be duplicated, disseminated, distributed or used for any purpose without express written permission.

Do not use for final construction. Sign fabricator to verify and be responsible for all dimensions and work conditions and inform this office of variations prior to performing work. Written dimensions govern over scaled dimensions.

No.	Revisions

Date 15 May 2017

Project No. UCONN-046

Phase CID

Project Title
 University of Connecticut
 Campus Wayfinding

Sign Type B3
Tertiary Vehicular
Directional

CID.25

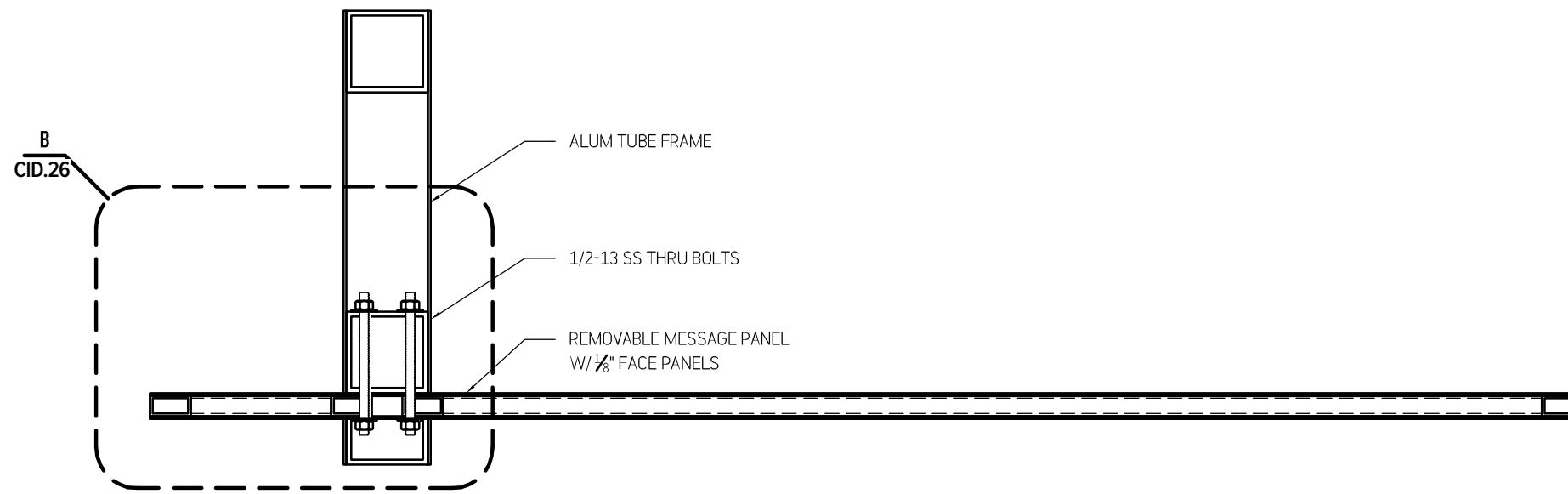

A SECTION
1 1/2" - 1'-0"

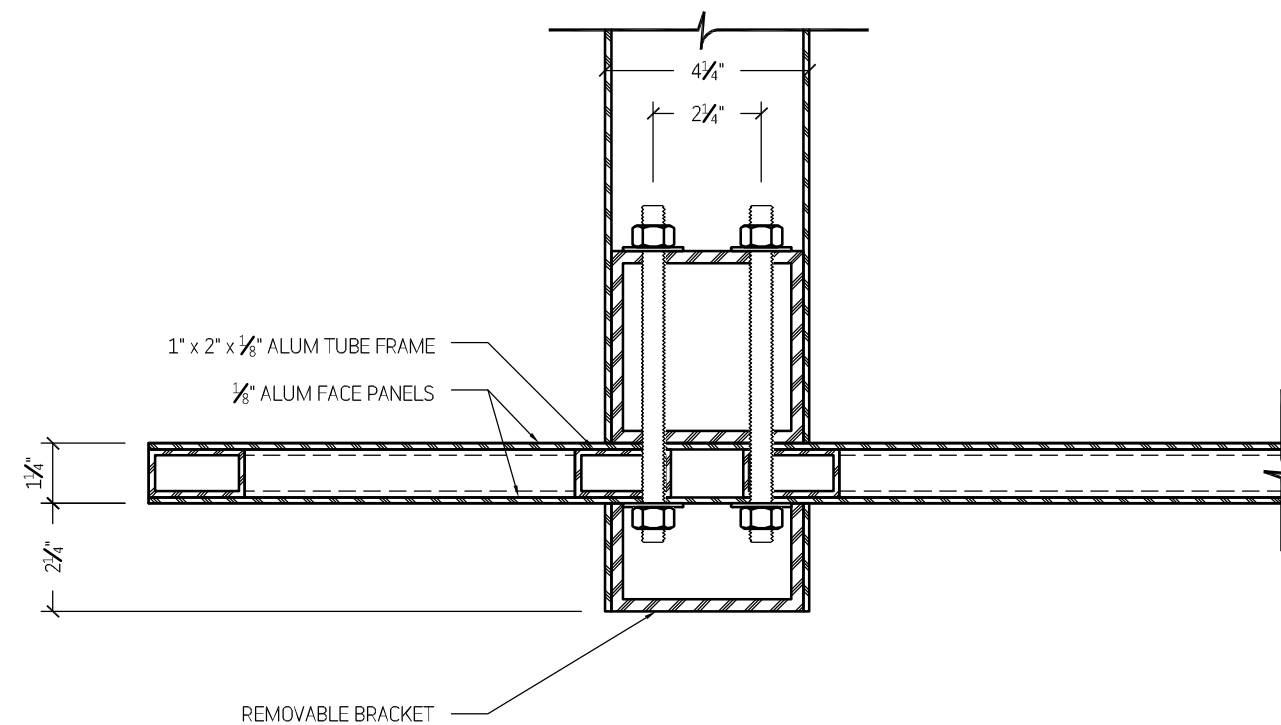

B SECTION
3" - 1'-0"

TWO TWELVE

902 BROADWAY
FLOOR 20
NEW YORK, NY
10010/6002
212 254/6670 T
212 254/6614 F

For Planning & Coordination Only –
Not for Construction

This document and the entirety of its contents are property of 212/Harakawa Inc. and/or Two Twelve Associates, Inc. No part of this document shall be duplicated, disseminated, distributed or used for any purpose without express written permission.

Do not use for final construction. Sign fabricator to verify and be responsible for all dimensions and work conditions and inform this office of variations prior to performing work. Written dimensions govern over scaled dimensions.

No.	Revisions
-----	-----------

Date 15 May 2017

Project No. UCONN-046

Phase CID

Project Title
University of Connecticut
Campus Wayfinding

Sign Type B3
Tertiary Vehicular
Directional

CID.26

TWO TWELVE

902 BROADWAY
 FLOOR 20
 NEW YORK, NY
 10010/6002
 212 254/6670 T
 212 254/6614 F

For Planning & Coordination Only –
 Not for Construction

This document and the entirety of its contents are property of 212/Harakawa Inc. and/or Two Twelve Associates, Inc. No part of this document shall be duplicated, disseminated, distributed or used for any purpose without express written permission.

Do not use for final construction. Sign fabricator to verify and be responsible for all dimensions and work conditions and inform this office of variations prior to performing work. Written dimensions govern over scaled dimensions.

No.	Revisions

Date 15 May 2017

Project No. UCONN-046

Phase CID

Project Title
 University of Connecticut
 Campus Wayfinding

Sign Type B3
 Tertiary Vehicular
 Directional

CID.27

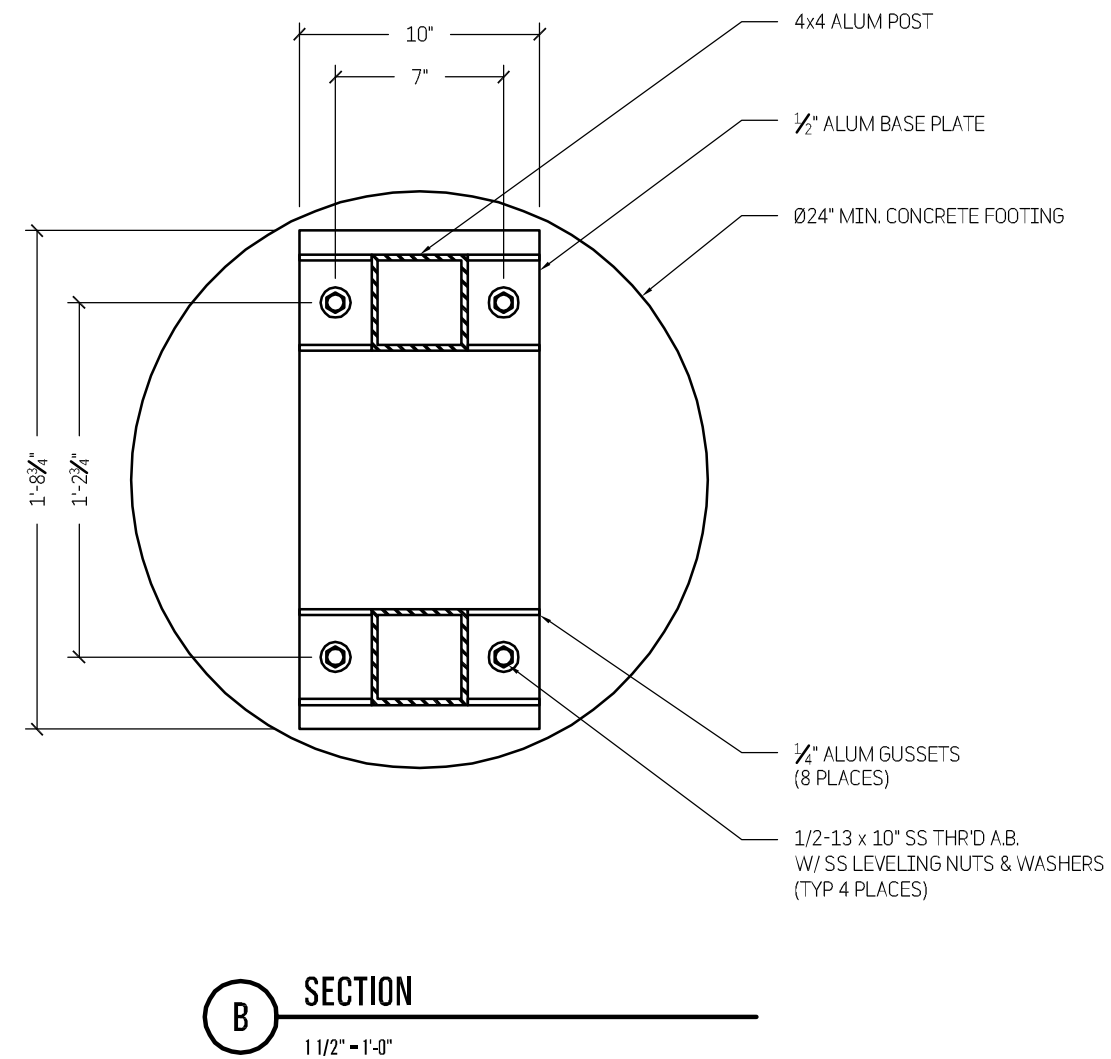
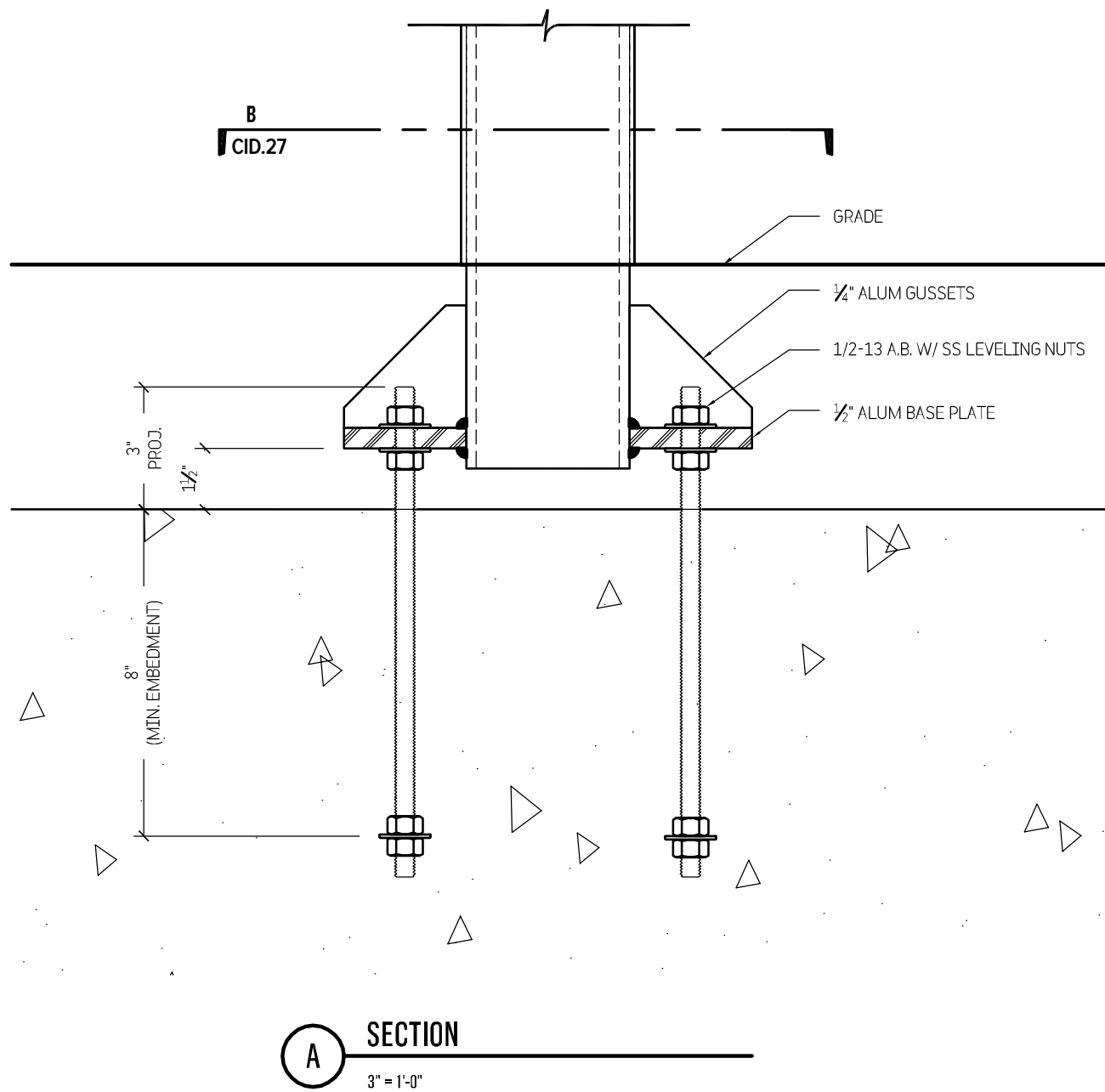

Double-sided variation is permissible on a case-by-case basis upon request to the University's Representative.

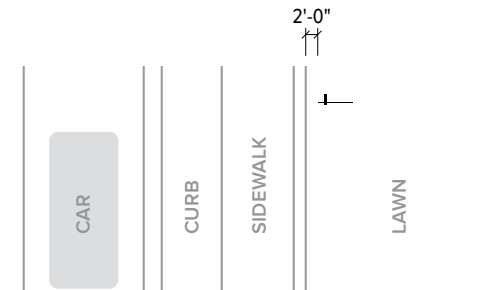
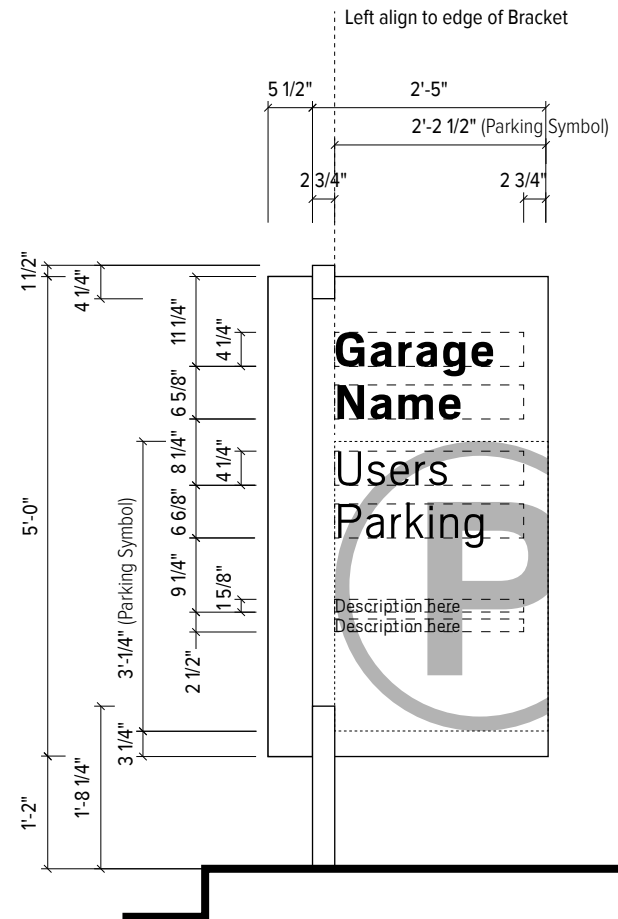
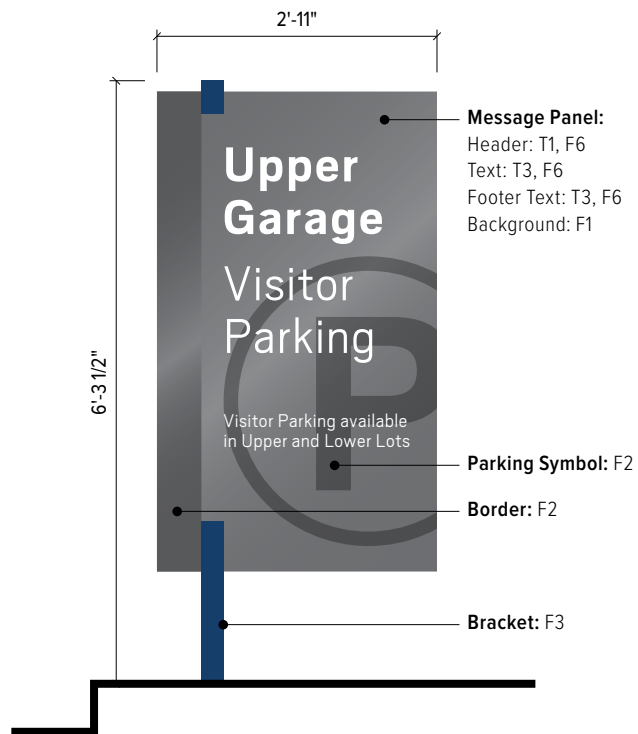

NOTE: Sign orientation to be determined by University Representative

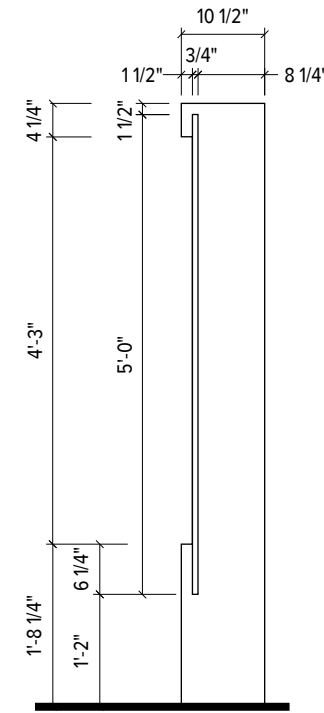

TWO TWELVE

902 BROADWAY
FLOOR 20
NEW YORK, NY
10010/6002
212 254/6670 T
212 254/6614 F

For Planning & Coordination Only –
Not for Construction

This document and the entirety of its contents are property of 212/Harakawa Inc. and/or Two Twelve Associates, Inc. No part of this document shall be duplicated, disseminated, distributed or used for any purpose without express written permission.

Do not use for final construction. Sign fabricator to verify and be responsible for all dimensions and work conditions and inform this office of variations prior to performing work. Written dimensions govern over scaled dimensions.

No.	Revisions

Date 15 May 2017

Project No. UCONN-046

Phase CID

Project Title

University of Connecticut
Campus Wayfinding

Sign Type D1
Primary Parking ID

CID.28

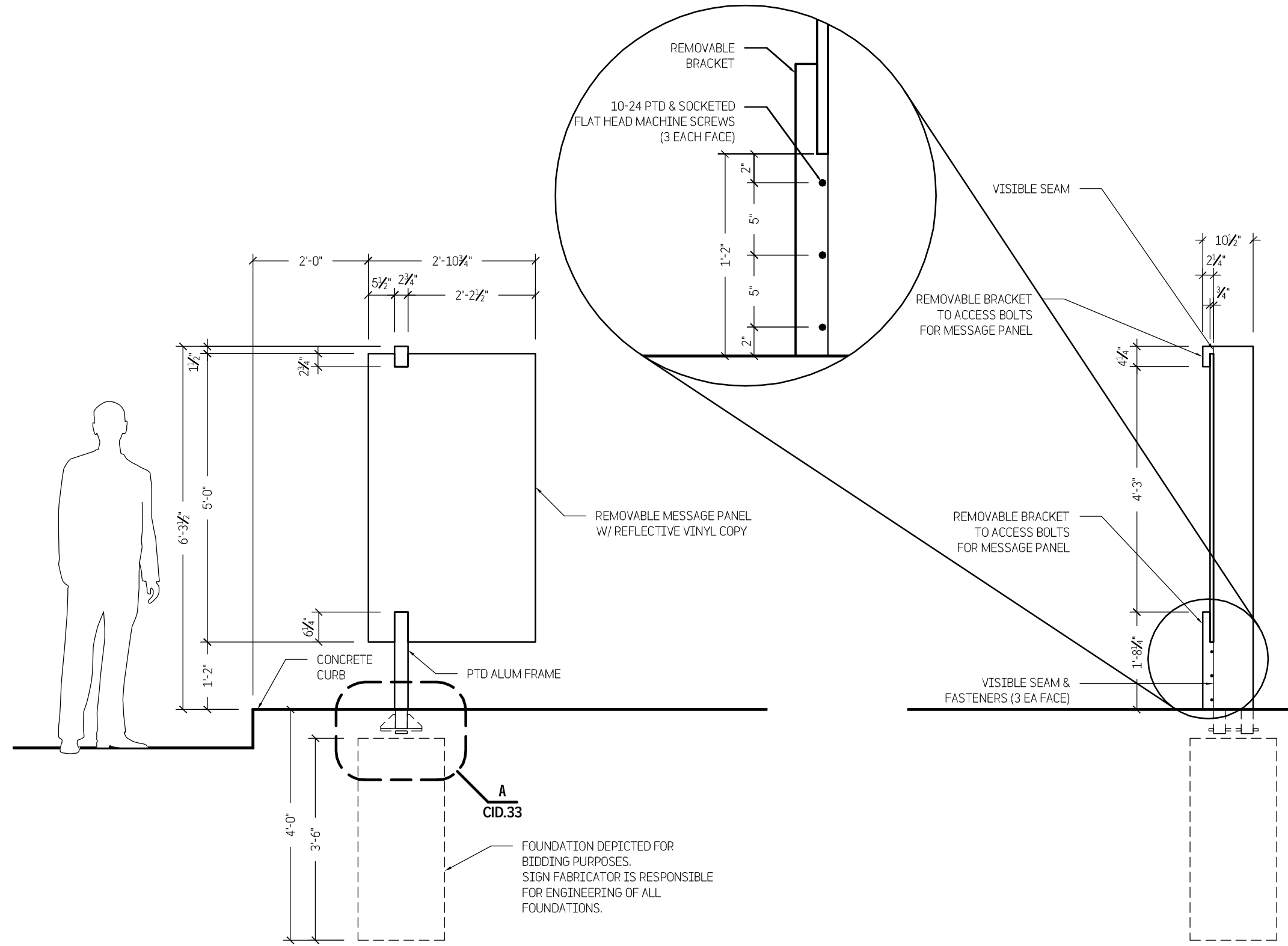

1 ELEVATION
1/2" = 1'-0"

2 SIDE VIEW
1/2" = 1'-0"

TWO TWELVE

902 BROADWAY
FLOOR 20
NEW YORK, NY
10010/6002
212 254/6670 T
212 254/6614 F

For Planning & Coordination Only –
Not for Construction

This document and the entirety of its contents are property of 212/Harakawa Inc. and/or Two Twelve Associates, Inc. No part of this document shall be duplicated, disseminated, distributed or used for any purpose without express written permission.

Do not use for final construction. Sign fabricator to verify and be responsible for all dimensions and work conditions and inform this office of variations prior to performing work. Written dimensions govern over scaled dimensions.

No.	Revisions
-----	-----------

Date 15 May 2017

Project No. UCONN-046

Phase CID

Project Title
University of Connecticut
Campus Wayfinding

Sign Type D1
Primary Parking ID

CID.29

TWO TWELVE

902 BROADWAY
 FLOOR 20
 NEW YORK, NY
 10010/6002
 212 254/6670 T
 212 254/6614 F

For Planning & Coordination Only –
 Not for Construction

This document and the entirety of its
 contents are property of 212/Harakawa
 Inc. and/or Two Twelve Associates, Inc.
 No part of this document shall be
 duplicated, disseminated, distributed
 or used for any purpose without
 express written permission.

Do not use for final construction. Sign
 fabricator to verify and be responsible
 for all dimensions and work conditions
 and inform this office of variations prior
 to performing work. Written dimensions
 govern over scaled dimensions.

No.	Revisions

Date 15 May 2017

Project No. UCONN-046

Phase CID

Project Title
 University of Connecticut
 Campus Wayfinding

**Sign Type D1
 Primary Parking ID**

CID.30

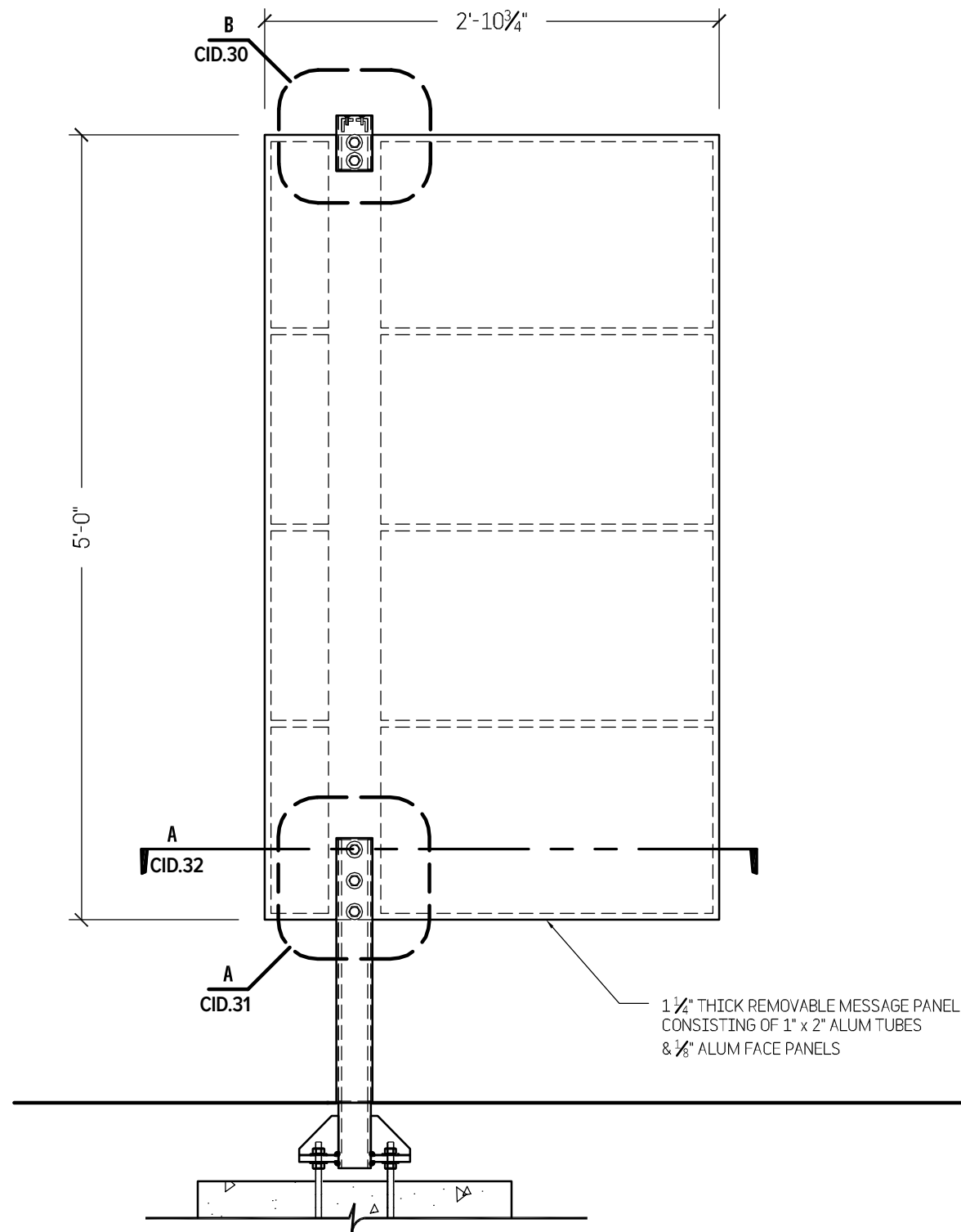

A SECTION
 1" = 1'-0"

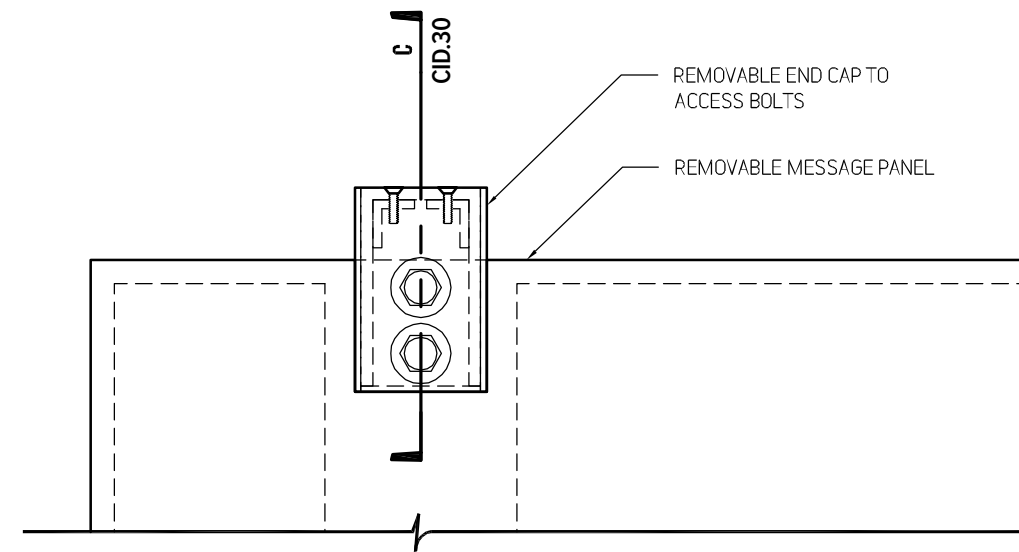

B SECTION
 3" = 1'-0"

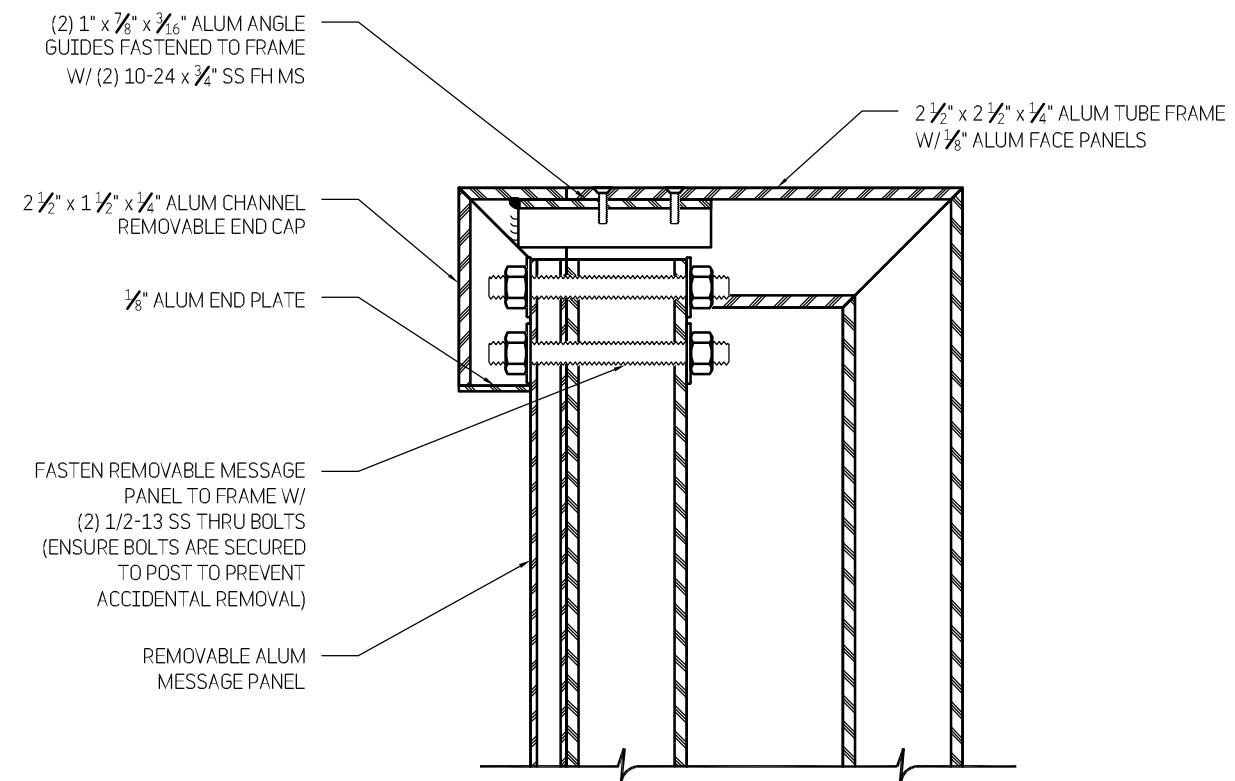

C SECTION
 3" = 1'-0"

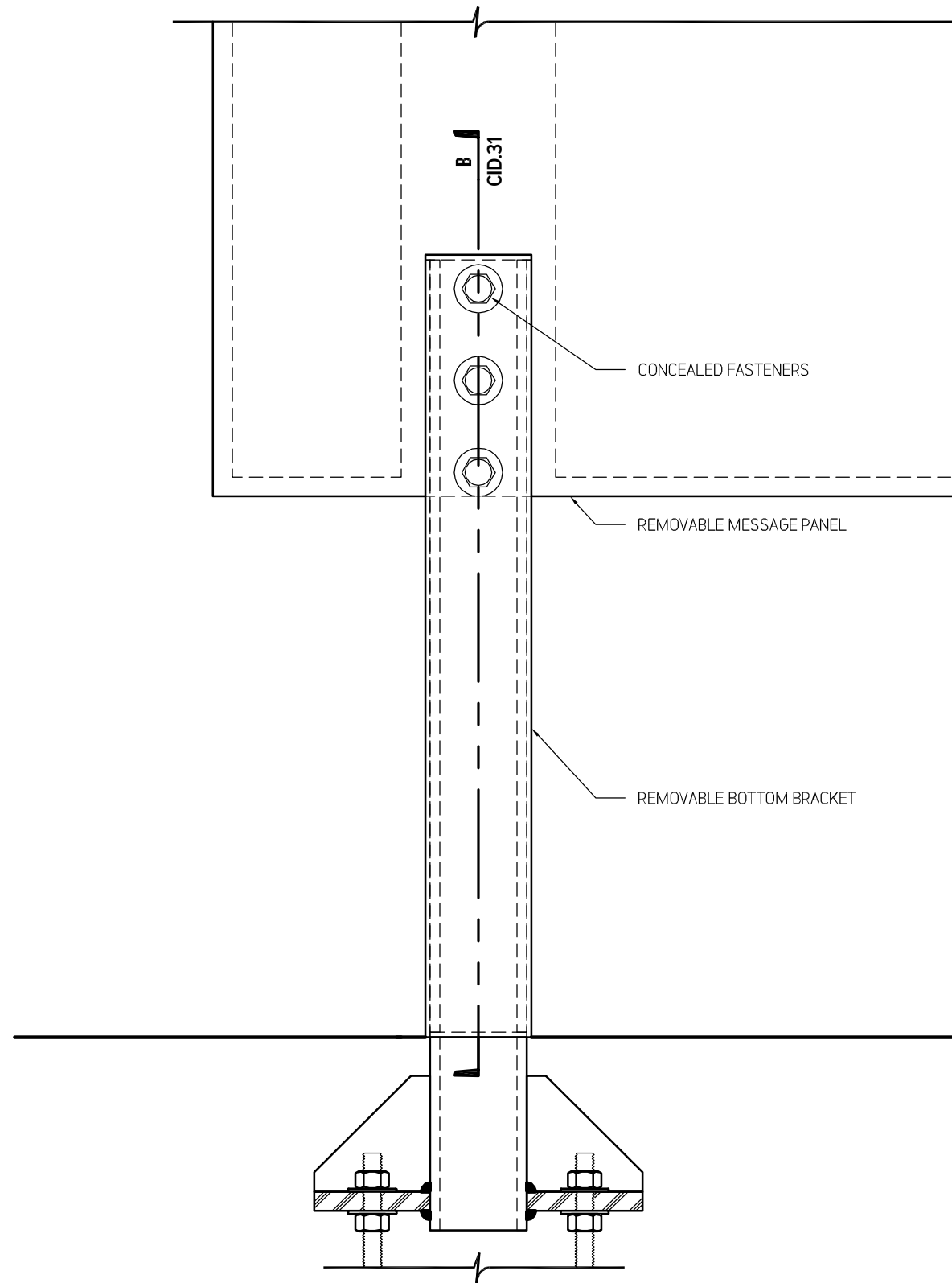

A SECTION
3" = 1'-0"

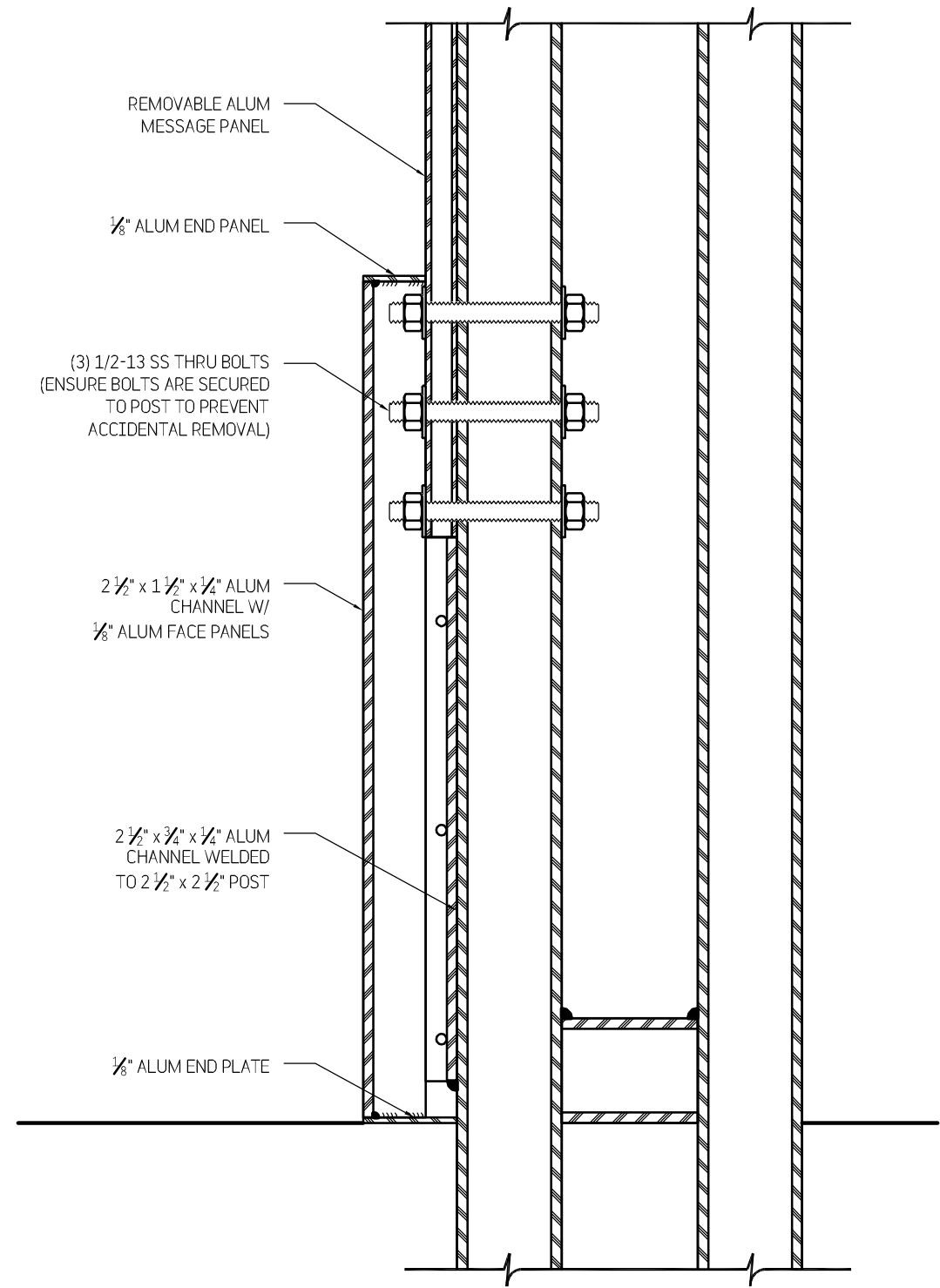

B SECTION
3" = 1'-0"

TWO TWELVE

902 BROADWAY
FLOOR 20
NEW YORK, NY
10010/6002
212 254/6670 T
212 254/6614 F

For Planning & Coordination Only –
Not for Construction

This document and the entirety of its
contents are property of 212/Harakawa
Inc. and/or Two Twelve Associates, Inc.
No part of this document shall be
duplicated, disseminated, distributed
or used for any purpose without
express written permission.

Do not use for final construction. Sign
fabricator to verify and be responsible
for all dimensions and work conditions
and inform this office of variations prior
to performing work. Written dimensions
govern over scaled dimensions.

No.	Revisions

Date 15 May 2017

Project No. UCONN-046

Phase CID

Project Title
University of Connecticut
Campus Wayfinding

Sign Type D1
Primary Parking ID

CID.31

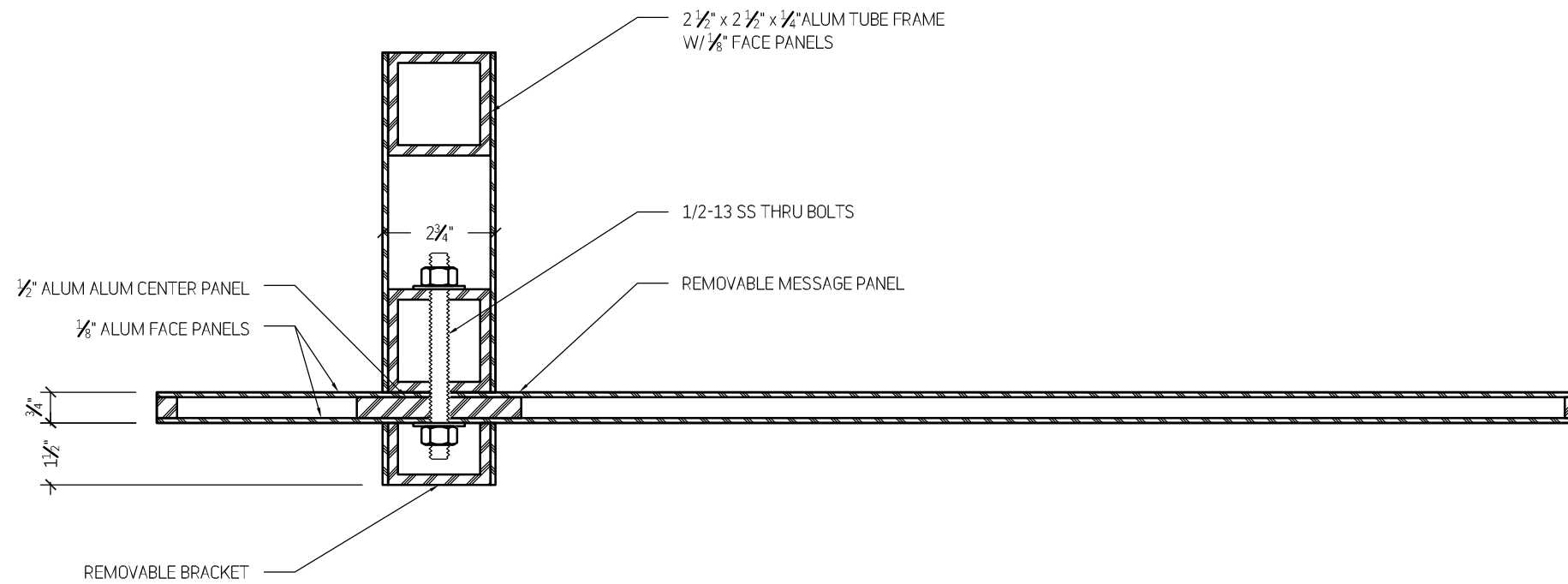

A SECTION
3" - 1'-0"

TWO TWELVE

902 BROADWAY
FLOOR 20
NEW YORK, NY
10010/6002
212 254/6670 T
212 254/6614 F

For Planning & Coordination Only –
Not for Construction

This document and the entirety of its
contents are property of 212/Harakawa
Inc. and/or Two Twelve Associates, Inc.
No part of this document shall be
duplicated, disseminated, distributed
or used for any purpose without
express written permission.

Do not use for final construction. Sign
fabricator to verify and be responsible
for all dimensions and work conditions
and inform this office of variations prior
to performing work. Written dimensions
govern over scaled dimensions.

No.	Revisions

Date 15 May 2017

Project No. UCONN-046

Phase CID

Project Title

University of Connecticut
Campus Wayfinding

Sign Type D1
Primary Parking ID

CID.32

TWO TWELVE

902 BROADWAY
 FLOOR 20
 NEW YORK, NY
 10010/6002
 212 254/6670 T
 212 254/6614 F

For Planning & Coordination Only –
 Not for Construction

This document and the entirety of its
 contents are property of 212/Harakawa
 Inc. and/or Two Twelve Associates, Inc.
 No part of this document shall be
 duplicated, disseminated, distributed
 or used for any purpose without
 express written permission.

Do not use for final construction. Sign
 fabricator to verify and be responsible
 for all dimensions and work conditions
 and inform this office of variations prior
 to performing work. Written dimensions
 govern over scaled dimensions.

No.	Revisions

Date 15 May 2017

Project No. UCONN-046

Phase CID

Project Title
 University of Connecticut
 Campus Wayfinding

Sign Type D1
Primary Parking ID

CID.33

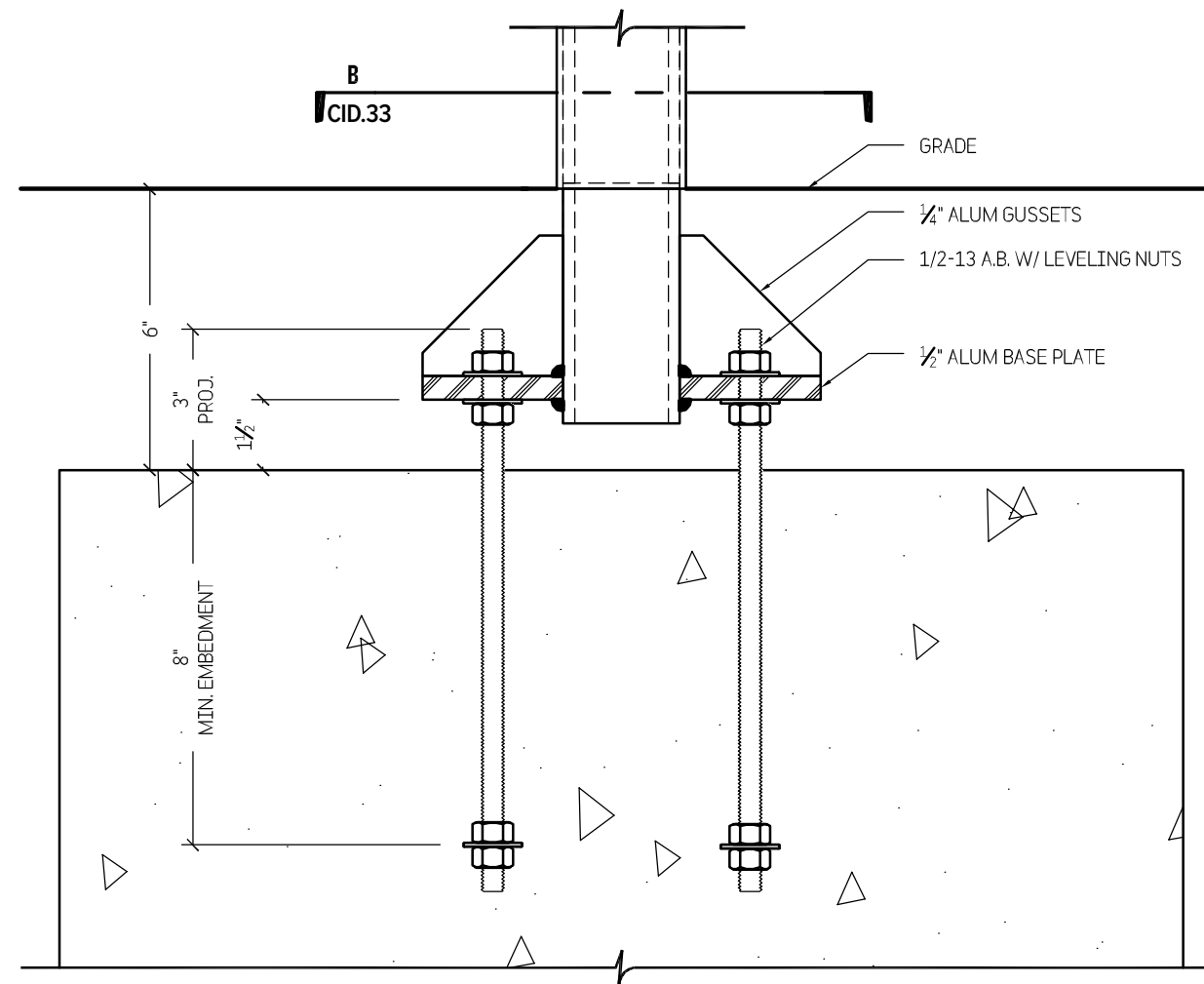

A SECTION
 3" = 1'-0"

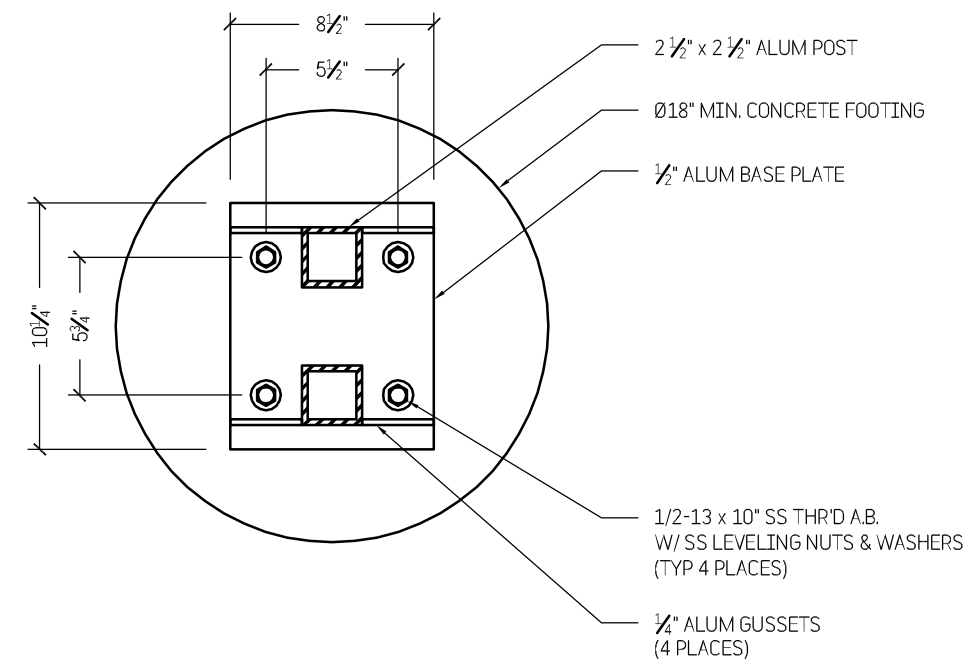

B SECTION
 1 1/2" = 1'-0"

Double-sided variation is permissible on a case-by-case basis upon request to the University's Representative.

TWO TWELVE

902 BROADWAY
FLOOR 20
NEW YORK, NY
10010/6002
212 254/6670 T
212 254/6614 F

For Planning & Coordination Only –
Not for Construction

This document and the entirety of its contents are property of 212/Harakawa Inc. and/or Two Twelve Associates, Inc. No part of this document shall be duplicated, disseminated, distributed or used for any purpose without express written permission.

Do not use for final construction. Sign fabricator to verify and be responsible for all dimensions and work conditions and inform this office of variations prior to performing work. Written dimensions govern over scaled dimensions.

No.	Revisions

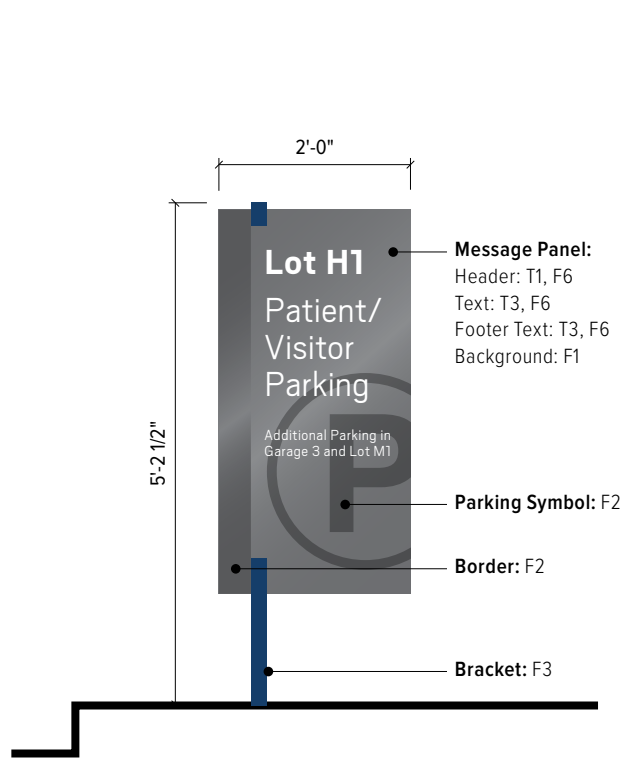

1 Elevation - Sign Type D2
1/2" = 1'-0"

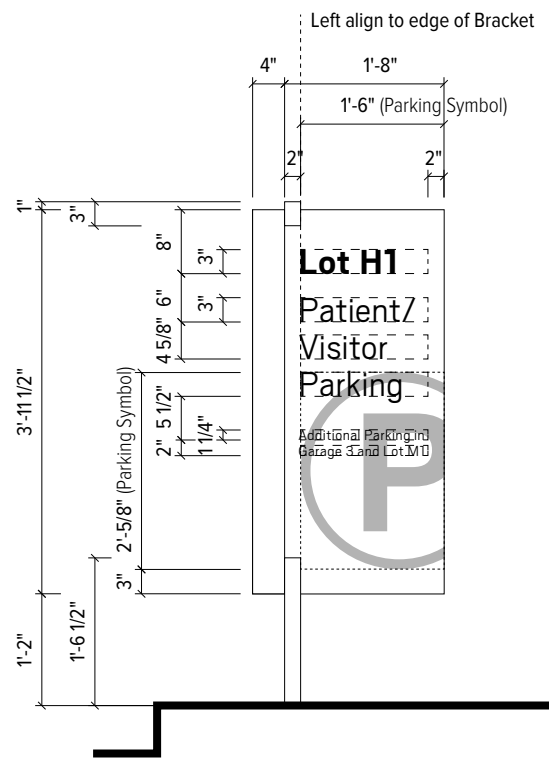

3 Graphic Layout - Sign Type D2
1/2" = 1'-0"



2 Plan - Sign Type D2
1/2" = 1'-0"

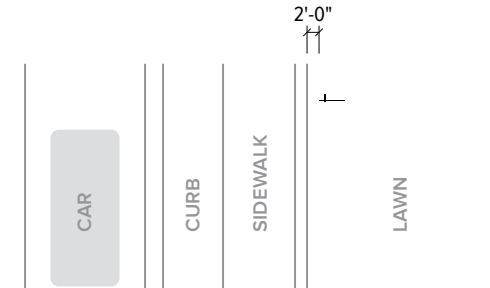

4 Installation Plan - Sign Type D2 (Typical)
NTS

NOTE: Sign orientation to be determined by University Representative

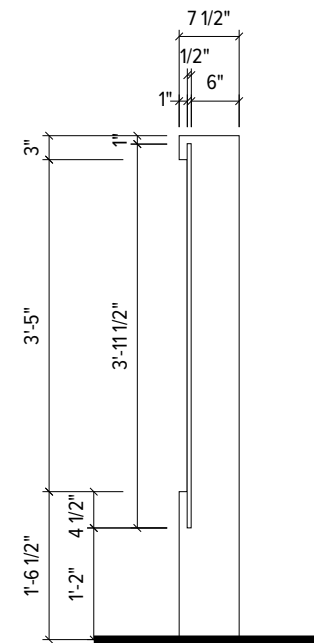

5 Side View - Sign Type D2
1/2" = 1'-0"

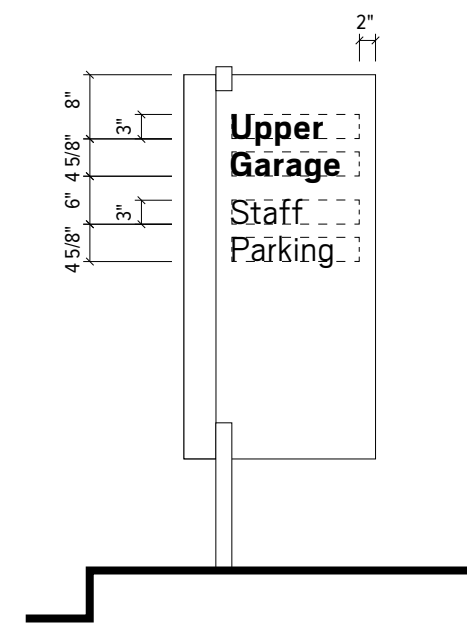

6 Alternate Graphic Layout - Sign Type D2
1/2" = 1'-0"

Date	15 May 2017
Project No.	UCONN-046
Phase	CID
Project Title	University of Connecticut Campus Wayfinding

Sign Type D2
Secondary Parking ID

CID.34

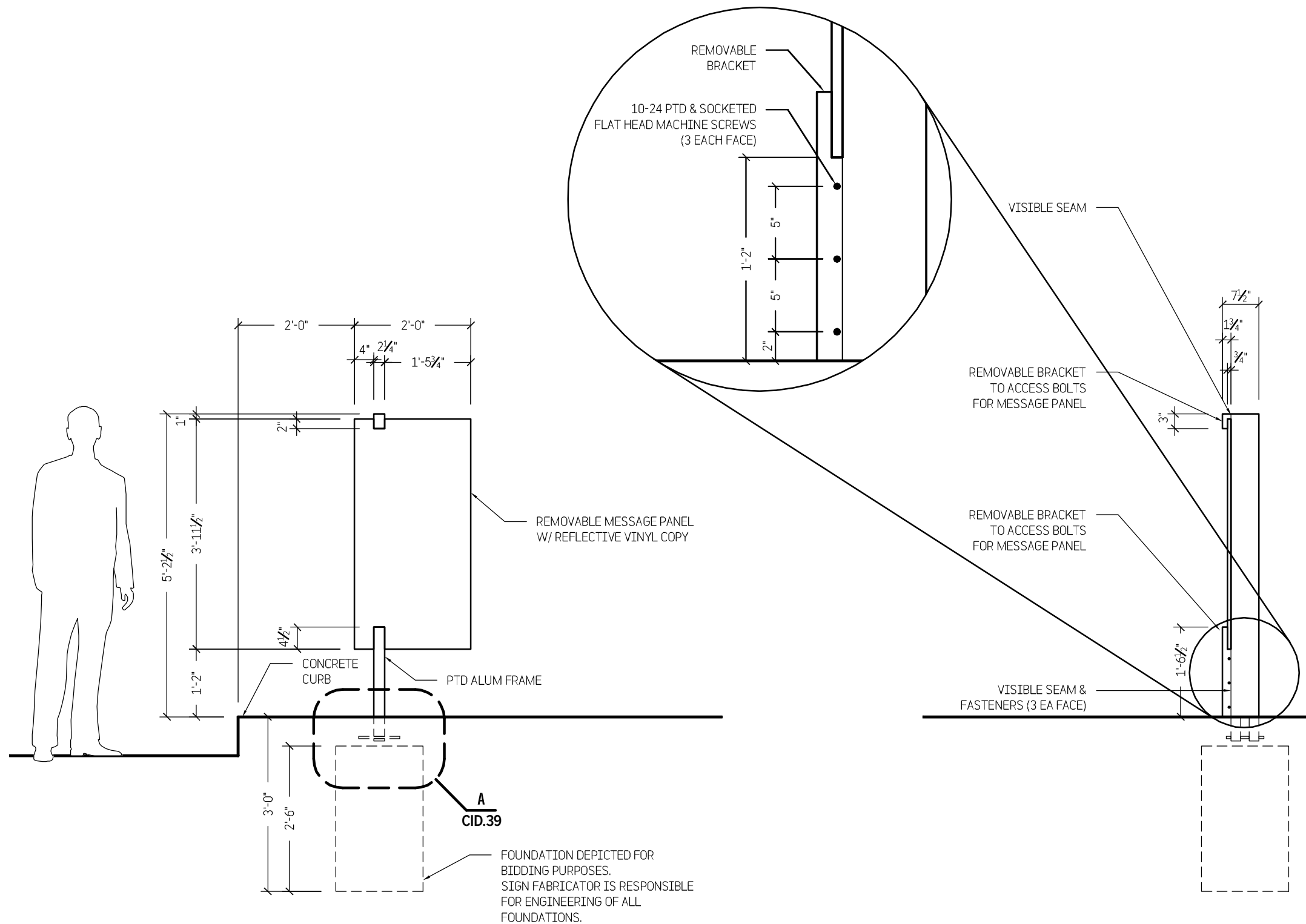

1 ELEVATION
1/2" = 1'-0"

2 SIDE VIEW
1/2" = 1'-0"

TWO TWELVE

902 BROADWAY
FLOOR 20
NEW YORK, NY
10010/6002
212 254/6670 T
212 254/6614 F

For Planning & Coordination Only –
Not for Construction

This document and the entirety of its
contents are property of 212/Harakawa
Inc. and/or Two Twelve Associates, Inc.
No part of this document shall be
duplicated, disseminated, distributed
or used for any purpose without
express written permission.

Do not use for final construction. Sign
fabricator to verify and be responsible
for all dimensions and work conditions
and inform this office of variations prior
to performing work. Written dimensions
govern over scaled dimensions.

No.	Revisions

Date 15 May 2017

Project No. UCONN-046

Phase CID

Project Title
University of Connecticut
Campus Wayfinding

Sign Type D2
Secondary Parking ID

CID.35

TWO TWELVE

902 BROADWAY
 FLOOR 20
 NEW YORK, NY
 10010/6002
 212 254/6670 T
 212 254/6614 F

For Planning & Coordination Only –
 Not for Construction

This document and the entirety of its
 contents are property of 212/Harakawa
 Inc. and/or Two Twelve Associates, Inc.
 No part of this document shall be
 duplicated, disseminated, distributed
 or used for any purpose without
 express written permission.

Do not use for final construction. Sign
 fabricator to verify and be responsible
 for all dimensions and work conditions
 and inform this office of variations prior
 to performing work. Written dimensions
 govern over scaled dimensions.

No.	Revisions

Date 15 May 2017

Project No. UCONN-046

Phase CID

Project Title
 University of Connecticut
 Campus Wayfinding

Sign Type D2
Secondary Parking ID

CID.36

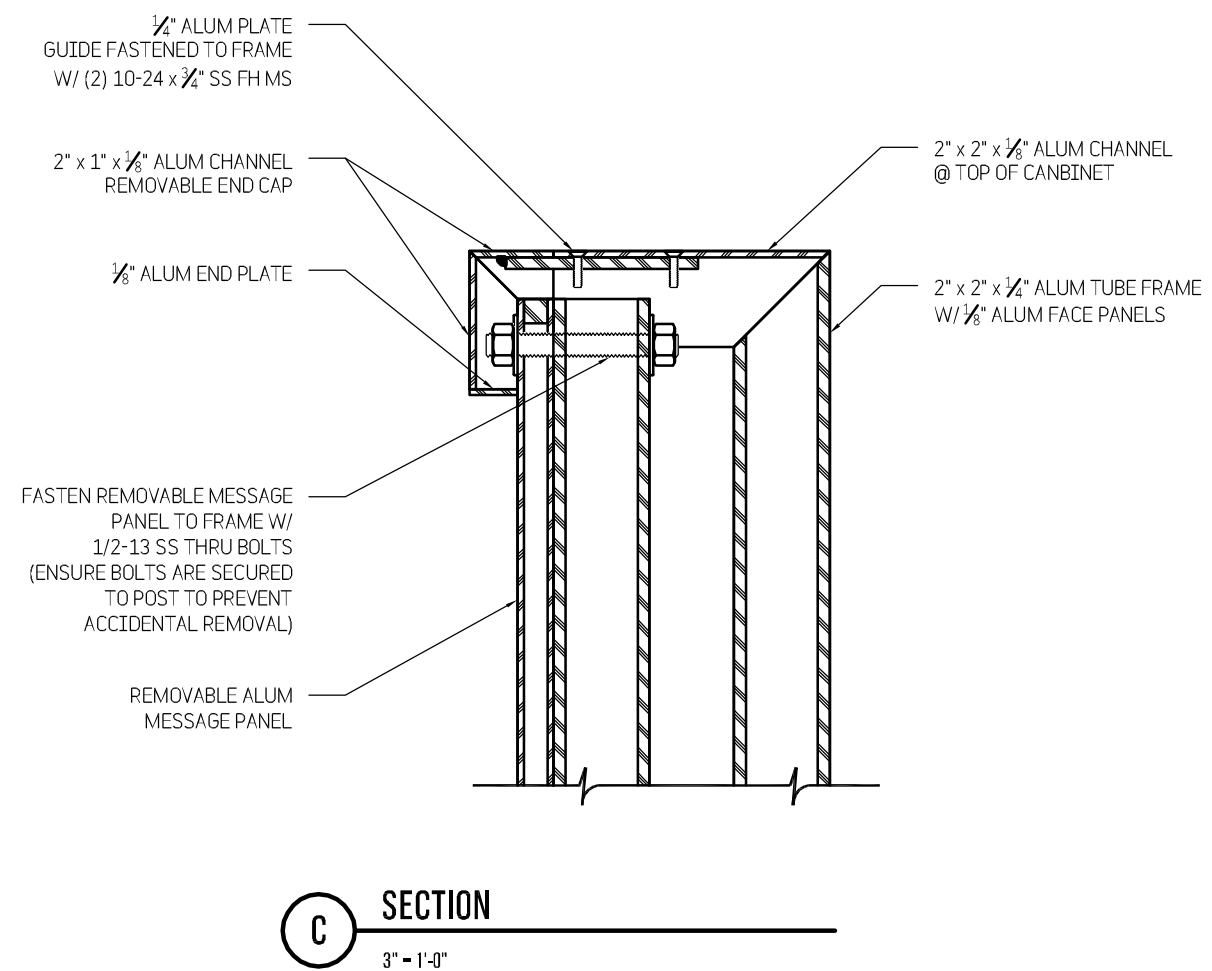
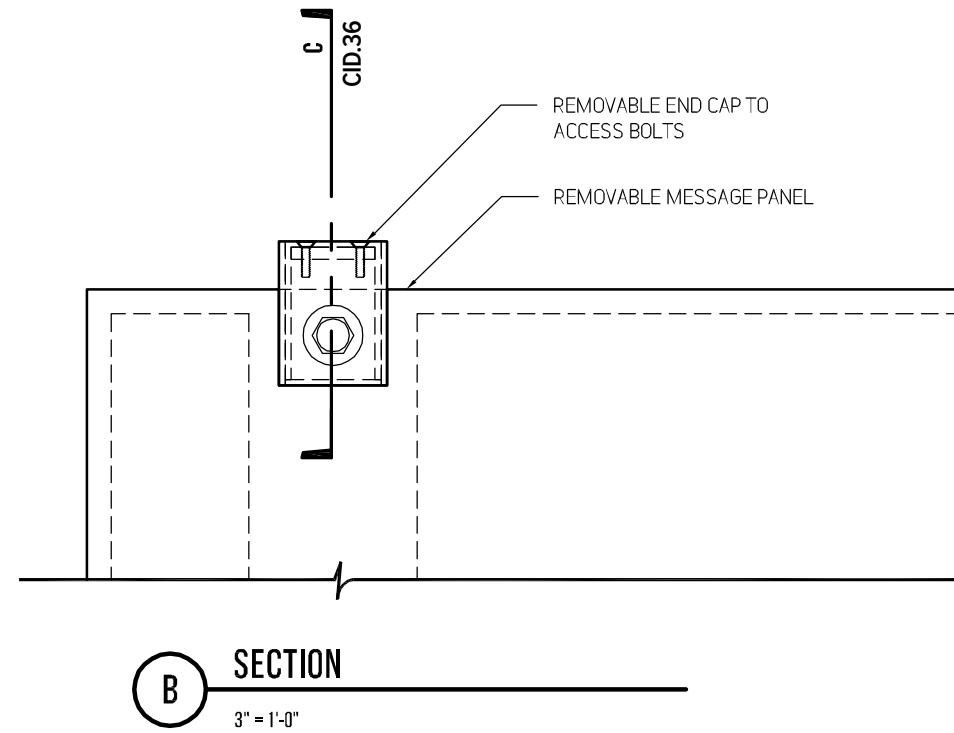
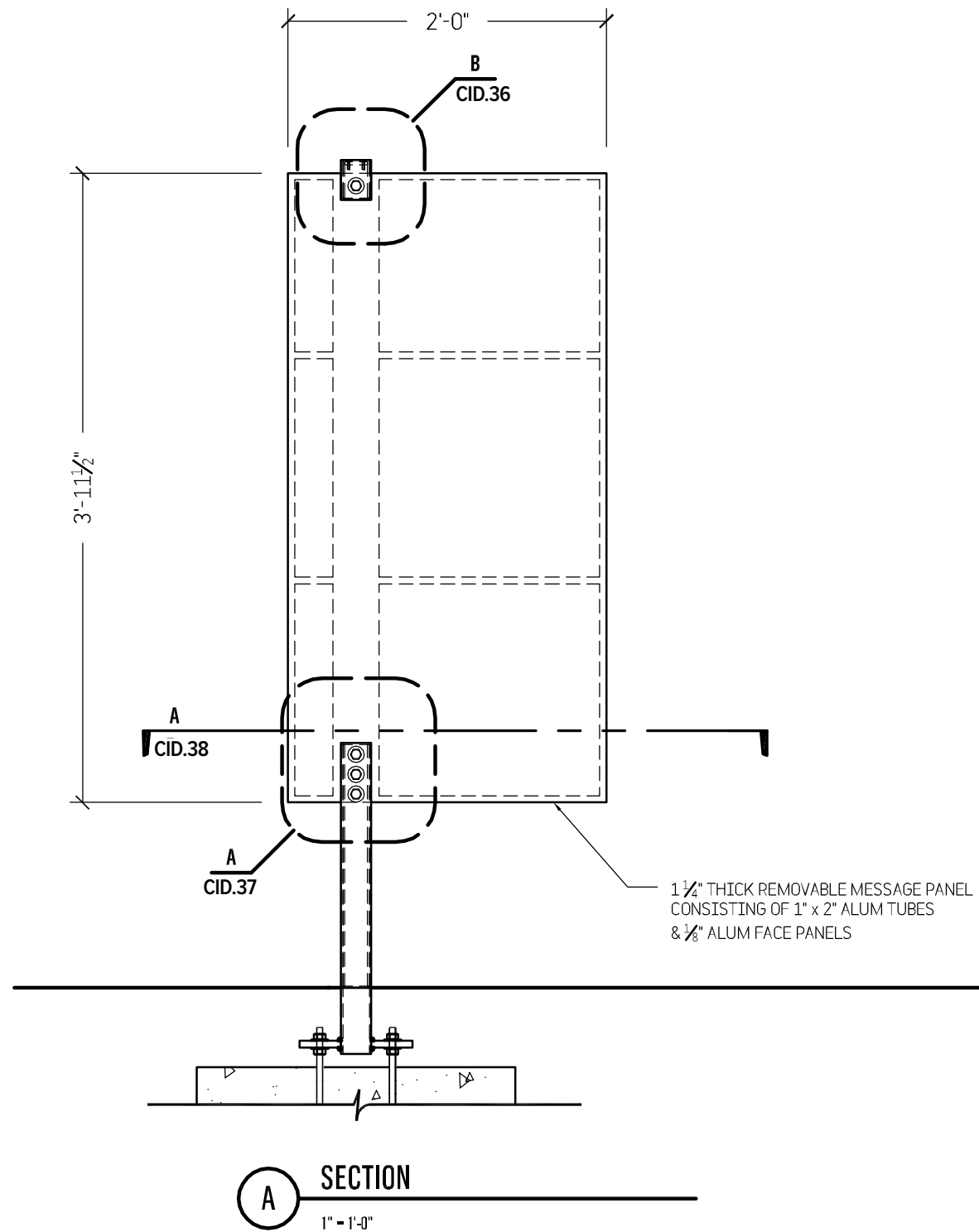

No.	Revisions

Date 15 May 2017

Project No. UCONN-046

Phase CID

Project Title
 University of Connecticut
 Campus Wayfinding

Sign Type D2
Secondary Parking ID

CID.36

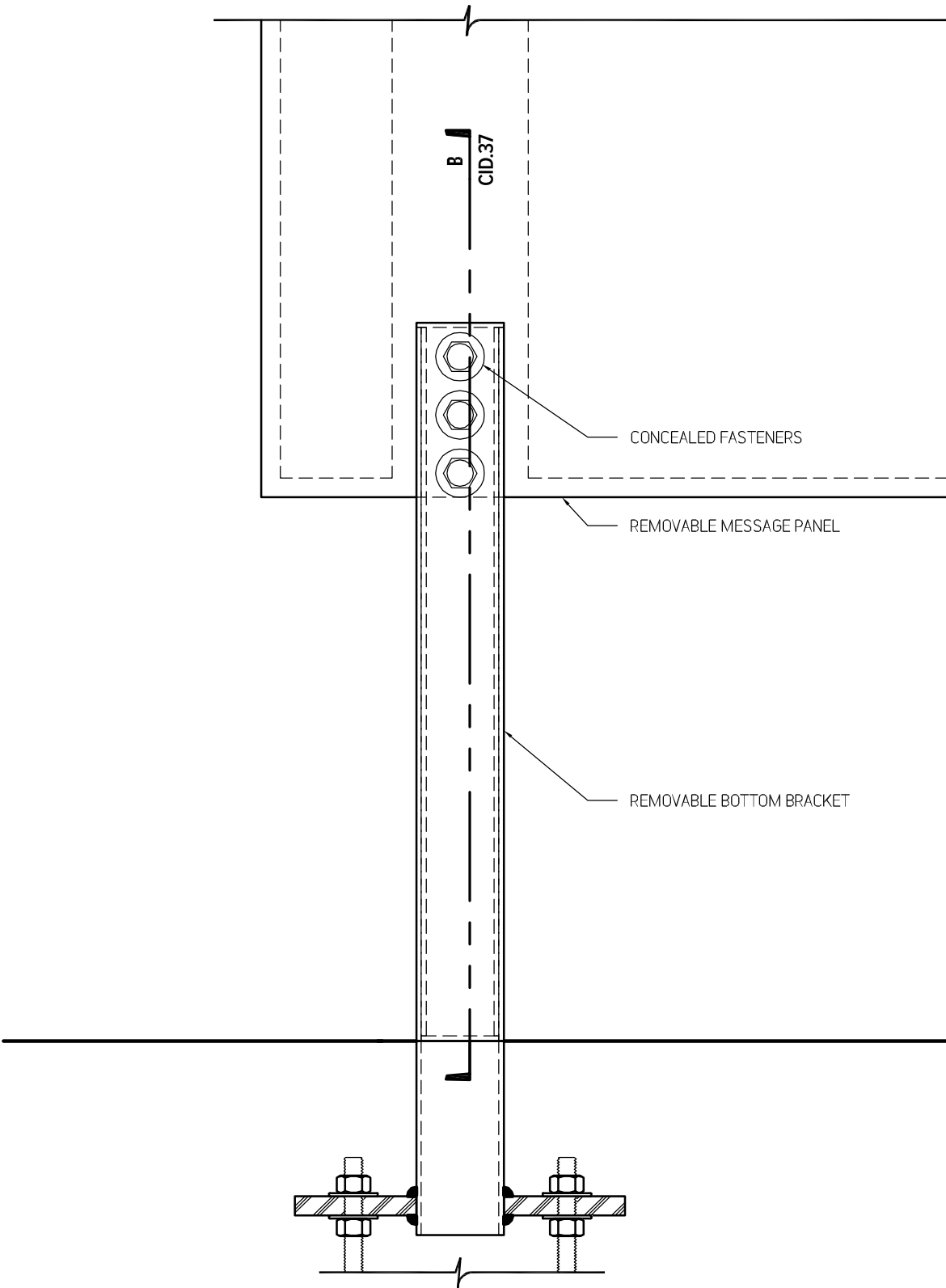

A SECTION
3" = 1'-0"

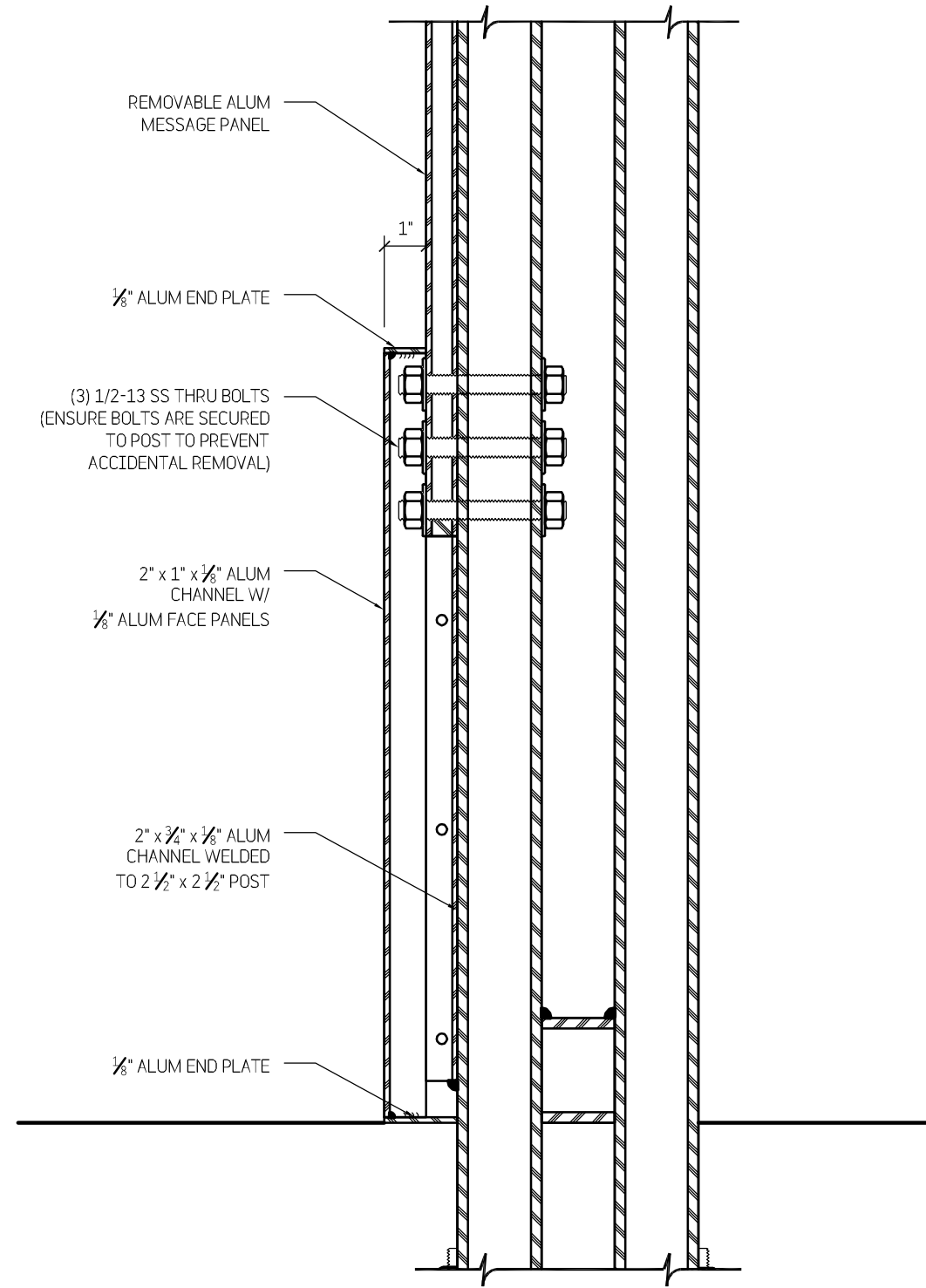

B SECTION
3" = 1'-0"

TWO TWELVE

902 BROADWAY
FLOOR 20
NEW YORK, NY
10010/6002
212 254/6670 T
212 254/6614 F

For Planning & Coordination Only –
Not for Construction

This document and the entirety of its
contents are property of 212/Harakawa
Inc. and/or Two Twelve Associates, Inc.
No part of this document shall be
duplicated, disseminated, distributed
or used for any purpose without
express written permission.

Do not use for final construction. Sign
fabricator to verify and be responsible
for all dimensions and work conditions
and inform this office of variations prior
to performing work. Written dimensions
govern over scaled dimensions.

No.	Revisions

Date 15 May 2017

Project No. UCONN-046

Phase CID

Project Title
University of Connecticut
Campus Wayfinding

Sign Type D2
Secondary Parking ID

CID.37

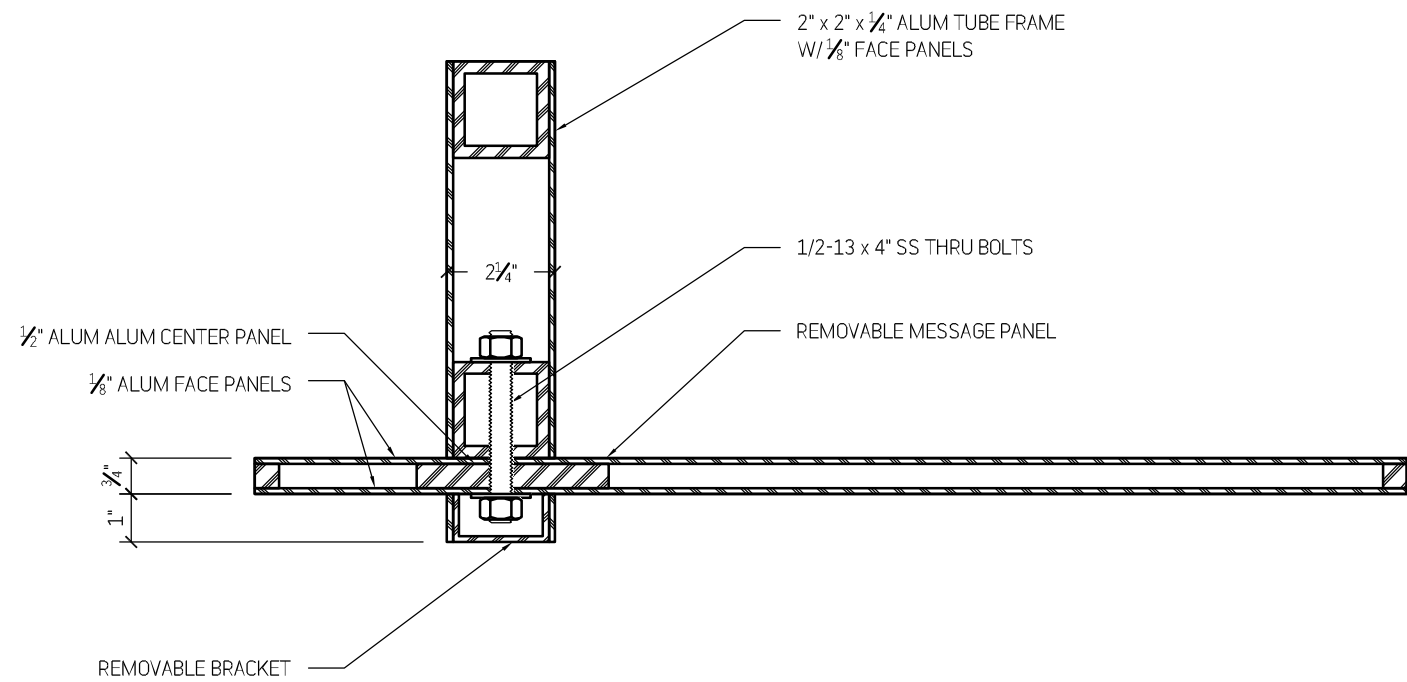

A SECTION
3" - 1'-0"

TWO TWELVE

902 BROADWAY
FLOOR 20
NEW YORK, NY
10010/6002
212 254/6670 T
212 254/6614 F

For Planning & Coordination Only –
Not for Construction

This document and the entirety of its
contents are property of 212/Harakawa
Inc. and/or Two Twelve Associates, Inc.
No part of this document shall be
duplicated, disseminated, distributed
or used for any purpose without
express written permission.

Do not use for final construction. Sign
fabricator to verify and be responsible
for all dimensions and work conditions
and inform this office of variations prior
to performing work. Written dimensions
govern over scaled dimensions.

No. Revisions

Date 15 May 2017

Project No. UCONN-046

Phase CID

Project Title

University of Connecticut
Campus Wayfinding

Sign Type D2
Secondary Parking ID

CID.38

TWO TWELVE

902 BROADWAY
 FLOOR 20
 NEW YORK, NY
 10010/6002
 212 254/6670 T
 212 254/6614 F

For Planning & Coordination Only –
 Not for Construction

This document and the entirety of its contents are property of 212/Harakawa Inc. and/or Two Twelve Associates, Inc. No part of this document shall be duplicated, disseminated, distributed or used for any purpose without express written permission.

Do not use for final construction. Sign fabricator to verify and be responsible for all dimensions and work conditions and inform this office of variations prior to performing work. Written dimensions govern over scaled dimensions.

No.	Revisions

Date 15 May 2017

Project No. UCONN-046

Phase CID

Project Title
 University of Connecticut
 Campus Wayfinding

Sign Type D2
Secondary Parking ID

CID.39

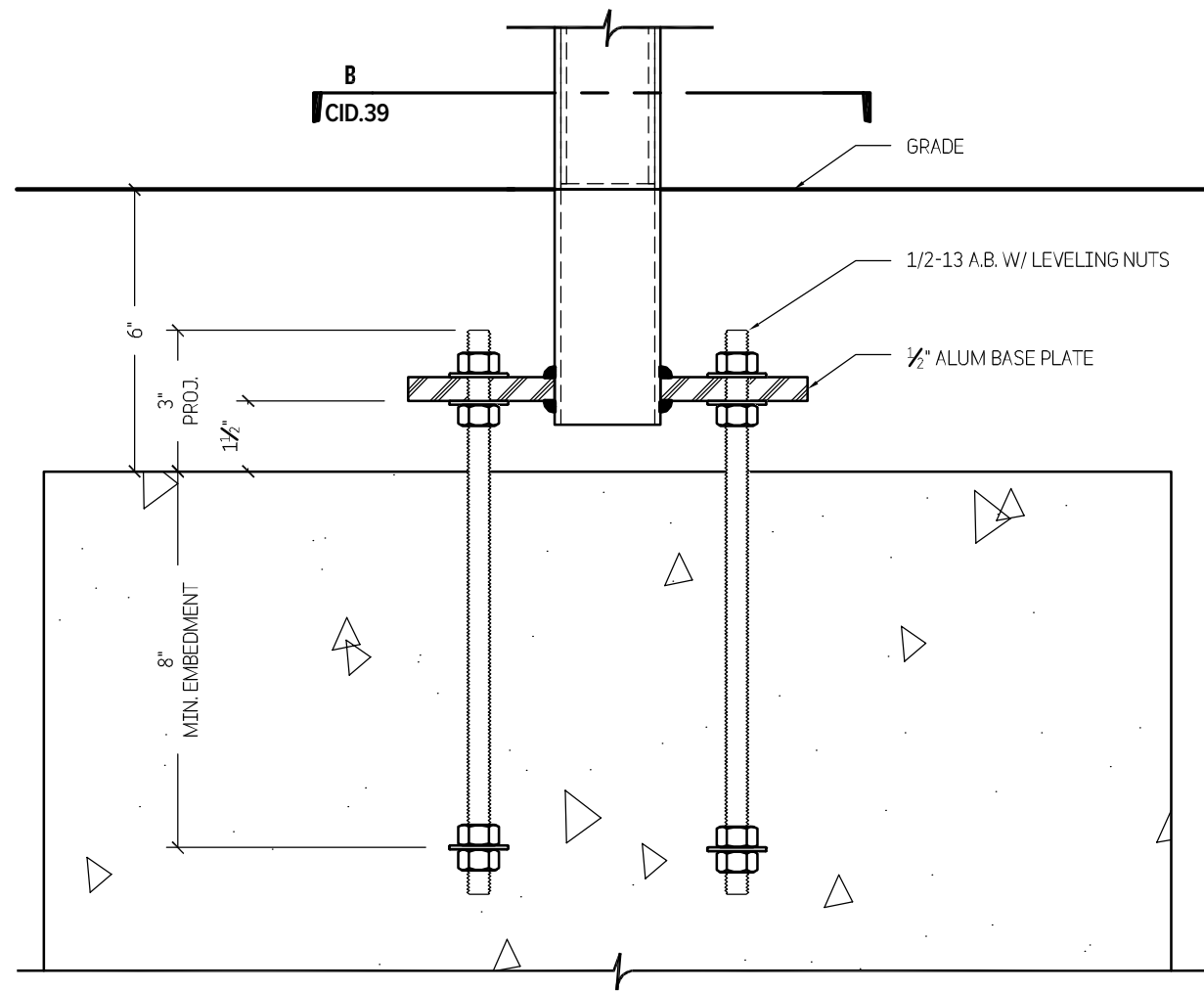

A SECTION
 3" = 1'-0"

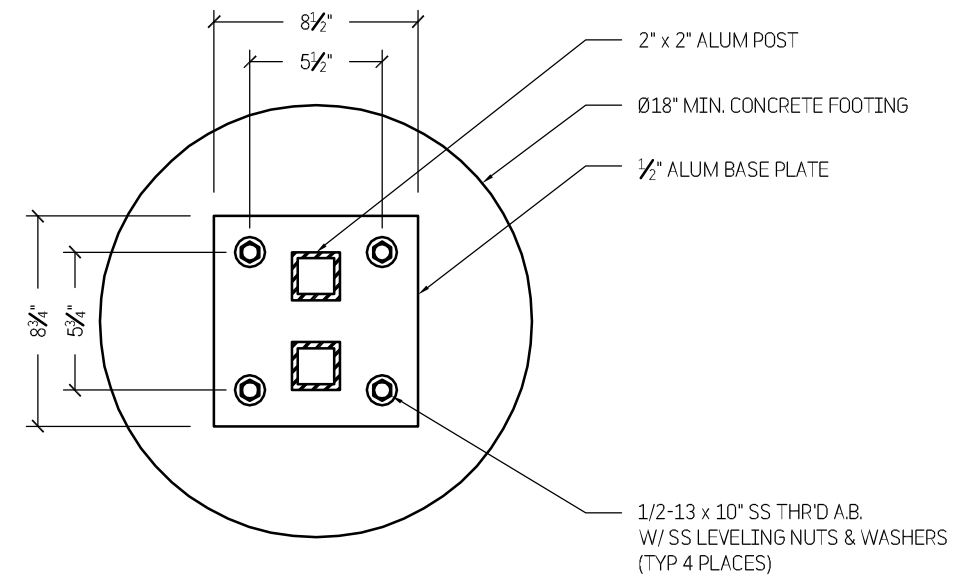

B SECTION
 1 1/2" = 1'-0"

TWO TWELVE

902 BROADWAY
 FLOOR 20
 NEW YORK, NY
 10010/6002
 212 254/6670 T
 212 254/6614 F

For Planning & Coordination Only –
 Not for Construction

This document and the entirety of its contents are property of 212/Harakawa Inc. and/or Two Twelve Associates, Inc. No part of this document shall be duplicated, disseminated, distributed or used for any purpose without express written permission.

Do not use for final construction. Sign fabricator to verify and be responsible for all dimensions and work conditions and inform this office of variations prior to performing work. Written dimensions govern over scaled dimensions.

No.	Revisions

Date	15 May 2017
------	-------------

Project No.	UCONN-046
-------------	-----------

Phase	CID
-------	-----

Project Title	University of Connecticut Campus Wayfinding
---------------	--

Sign Type E
Walkway ID

CID.40



2 Plan - Sign Type E
 3/4" = 1'-0"

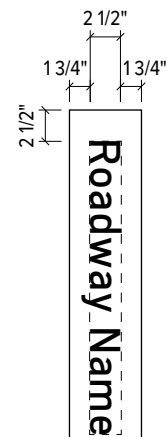

3 Graphic Layout - Sign Type E (Sides 1 & 2)
 3/4" = 1'-0"



4 Side View - Sign Type E
 3/4" = 1'-0"

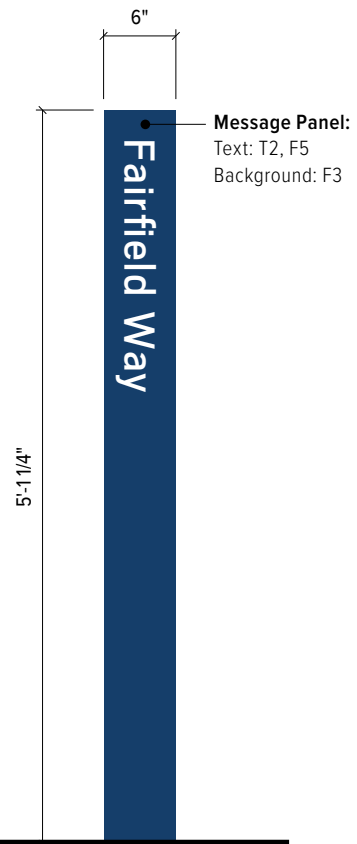

1 Elevation - Sign Type E
 3/4" = 1'-0"

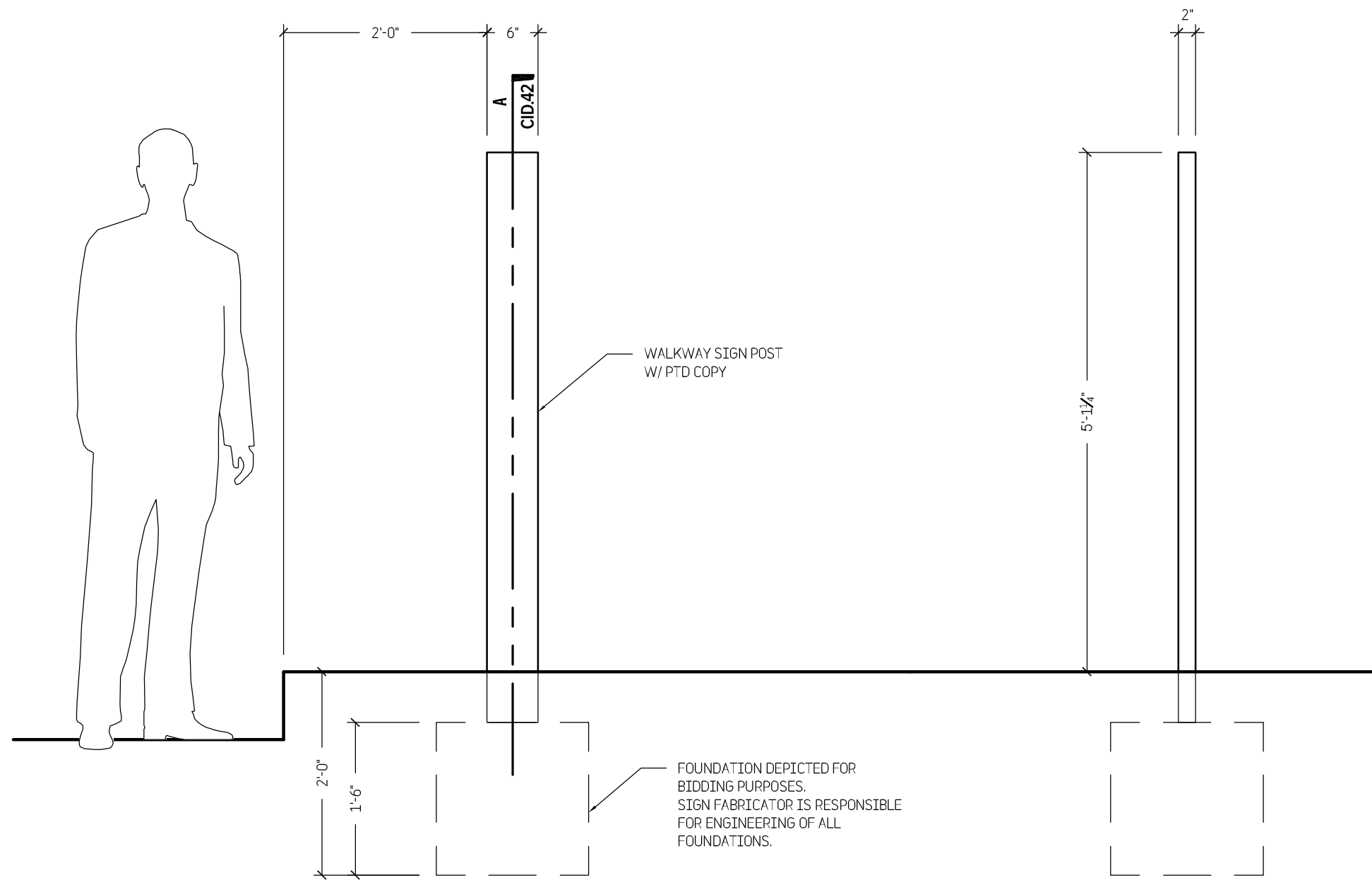

1 ELEVATION
3/4" = 1'-0"

2 SIDE VIEW
3/4" = 1'-0"

TWO TWELVE

902 BROADWAY
FLOOR 20
NEW YORK, NY
10010/6002
212 254/6670 T
212 254/6614 F

For Planning & Coordination Only –
Not for Construction

This document and the entirety of its contents are property of 212/Harakawa Inc. and/or Two Twelve Associates, Inc. No part of this document shall be duplicated, disseminated, distributed or used for any purpose without express written permission.

Do not use for final construction. Sign fabricator to verify and be responsible for all dimensions and work conditions and inform this office of variations prior to performing work. Written dimensions govern over scaled dimensions.

No.	Revisions
-----	-----------

Date 15 May 2017

Project No. UCONN-046

Phase CID

Project Title
University of Connecticut
Campus Wayfinding

Sign Type E
Walkway ID

CID.41

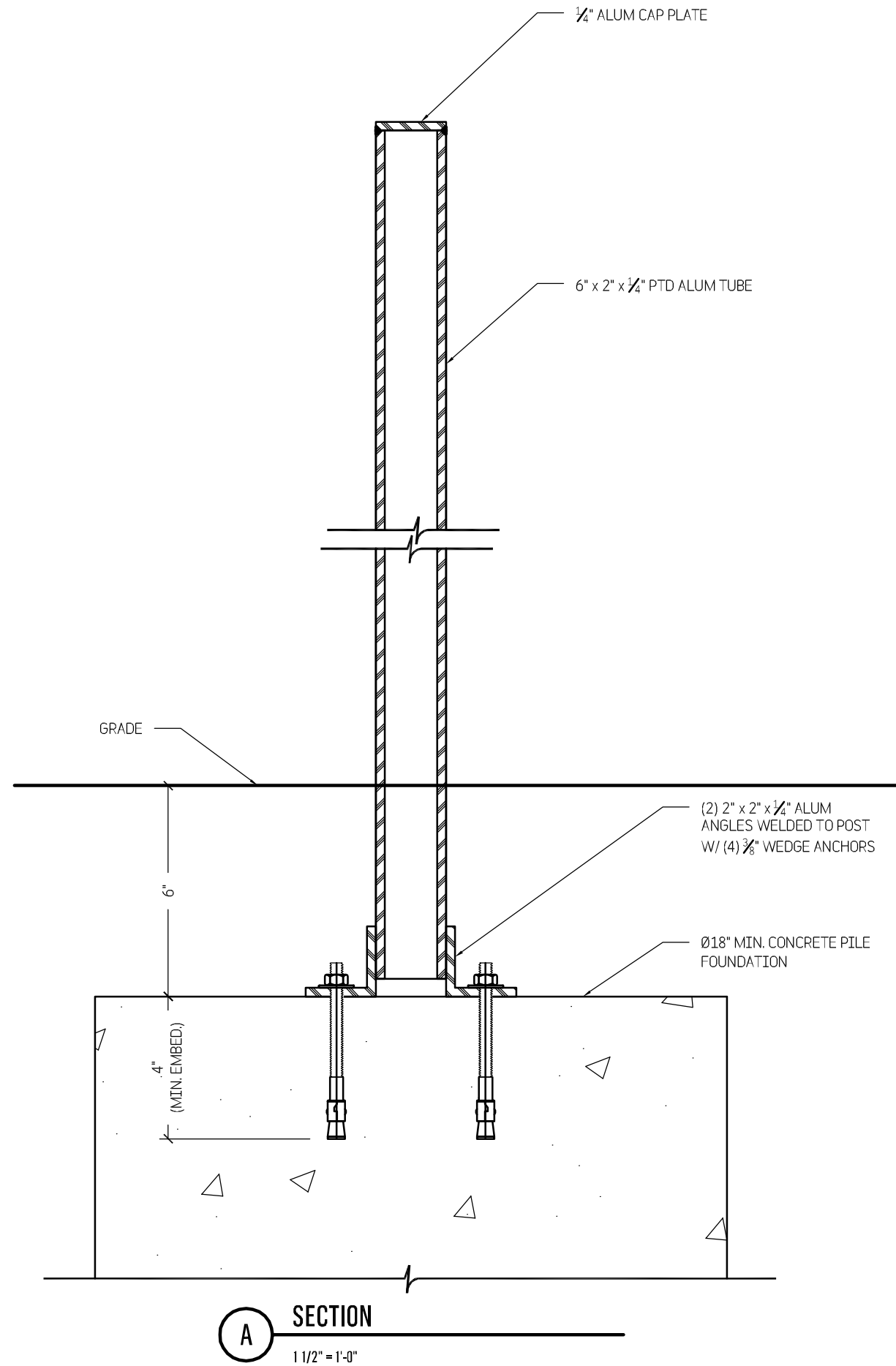

TWO TWELVE

902 BROADWAY
 FLOOR 20
 NEW YORK, NY
 10010/6002
 212 254/6670 T
 212 254/6614 F

For Planning & Coordination Only –
 Not for Construction

This document and the entirety of its contents are property of 212/Harakawa Inc. and/or Two Twelve Associates, Inc. No part of this document shall be duplicated, disseminated, distributed or used for any purpose without express written permission.

Do not use for final construction. Sign fabricator to verify and be responsible for all dimensions and work conditions and inform this office of variations prior to performing work. Written dimensions govern over scaled dimensions.

No.	Revisions
-----	-----------

Date 15 May 2017

Project No. UCONN-046

Phase CID

Project Title
 University of Connecticut
 Campus Wayfinding

Sign Type E
 Walkway ID

CID.42

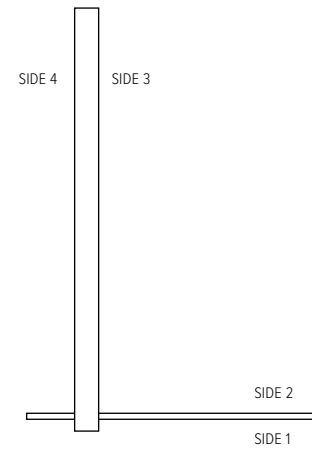

2 Plan - Sign Type G
3/4" = 1'-0"

See orientation options on page CID.44

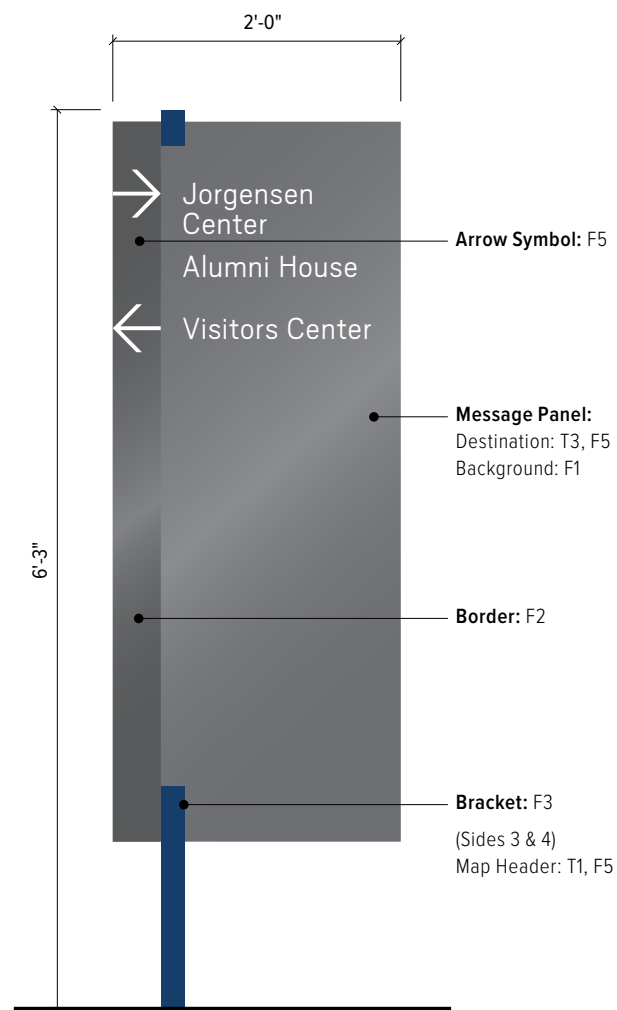

1 Elevation - Sign Type G (Side 1)
3/4" = 1'-0"

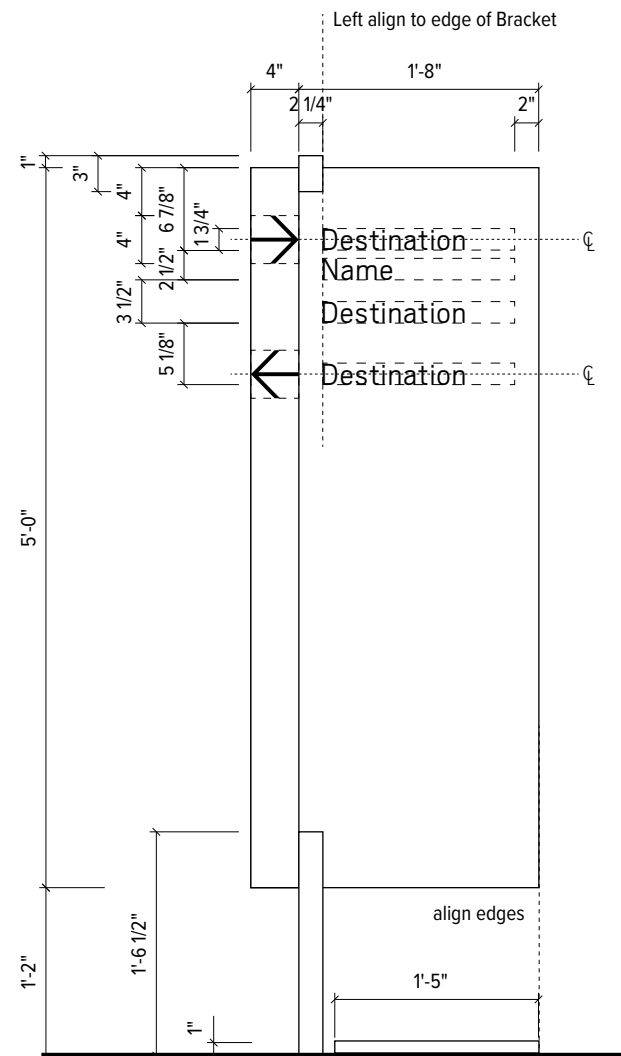

3 Graphic Layout - Sign Type G (Side 1)
3/4" = 1'-0"

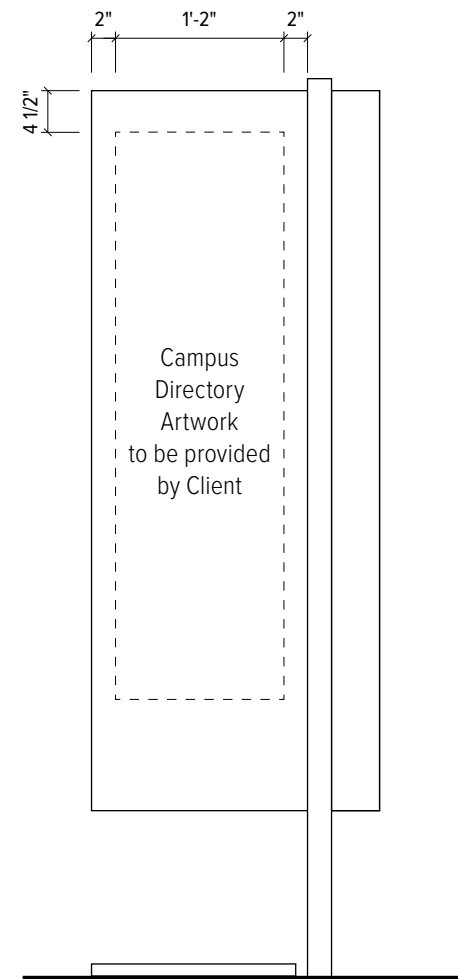

4 Graphic Layout - Sign Type G (Side 2)
3/4" = 1'-0"

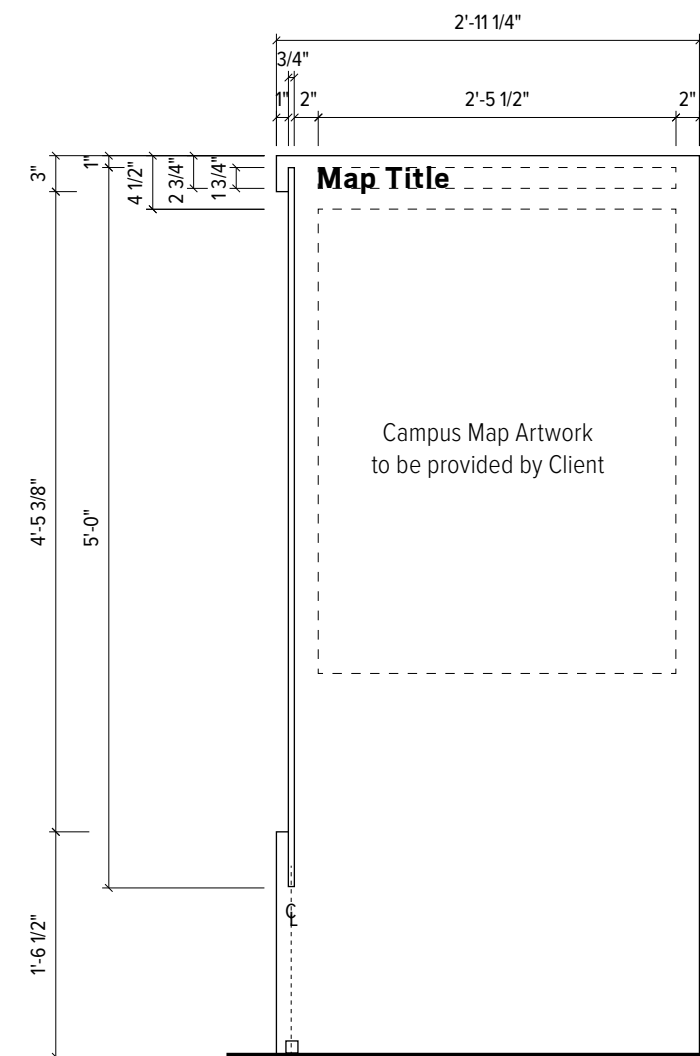

5 Side View - Sign Type G (Side 3)
3/4" = 1'-0"

TWO TWELVE

902 BROADWAY
FLOOR 20
NEW YORK, NY
10010/6002
212 254/6670 T
212 254/6614 F

For Planning & Coordination Only –
Not for Construction

This document and the entirety of its contents are property of 212/Harakawa Inc. and/or Two Twelve Associates, Inc. No part of this document shall be duplicated, disseminated, distributed or used for any purpose without express written permission.

Do not use for final construction. Sign fabricator to verify and be responsible for all dimensions and work conditions and inform this office of variations prior to performing work. Written dimensions govern over scaled dimensions.

No.	Revisions

Date	15 May 2017
Updated Date	04 Oct 2022

Project No. UCONN-046

Phase CID

Project Title

University of Connecticut
Campus Wayfinding

Sign Type G
Pedestrian Campus Kiosk

CID.43

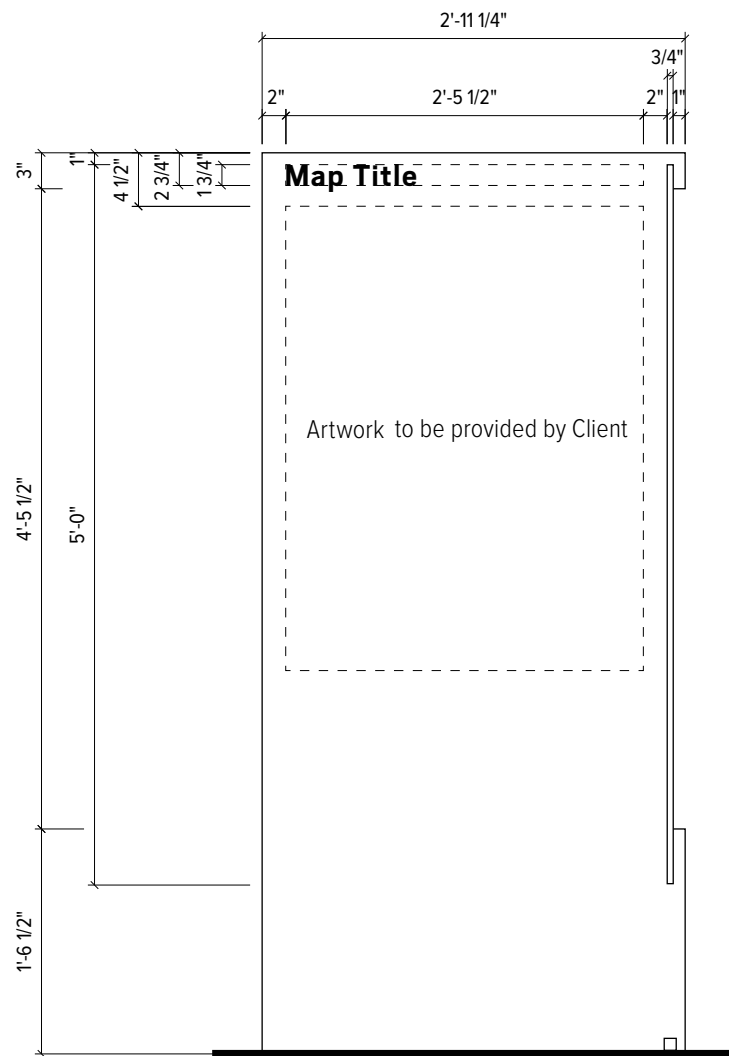

1 Side View - Sign Type H1 (Side 4)
3/4" = 1'-0"

ORIENTATIONS

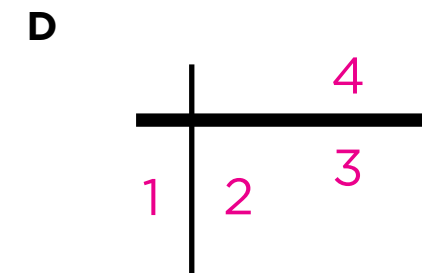
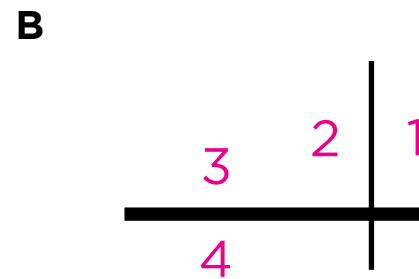
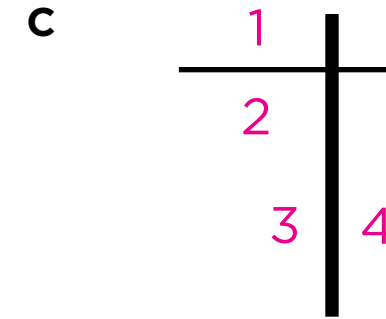
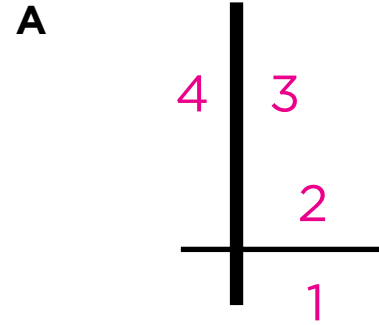

KEY: SIDES
 1 DIRECTIONAL
 2 DIRECTORY
 3 MAP
 4 UCONN NATION

ORIENTATIONS ALTERNATE

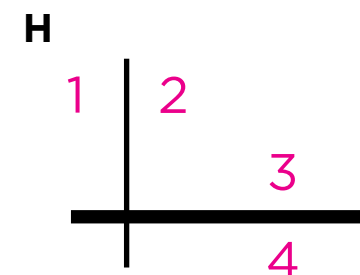
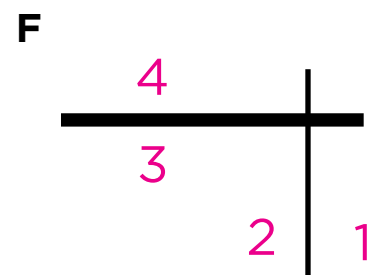
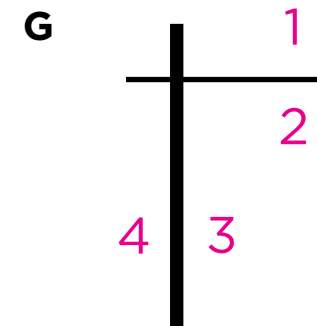
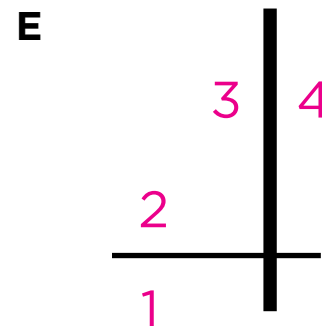

TWO TWELVE

902 BROADWAY
 FLOOR 20
 NEW YORK, NY
 10010/6002
 212 254/6670 T
 212 254/6614 F

For Planning & Coordination Only –
 Not for Construction

This document and the entirety of its
 contents are property of 212/Harakawa
 Inc. and/or Two Twelve Associates, Inc.
 No part of this document shall be
 duplicated, disseminated, distributed
 or used for any purpose without
 express written permission.

Do not use for final construction. Sign
 fabricator to verify and be responsible
 for all dimensions and work conditions
 and inform this office of variations prior
 to performing work. Written dimensions
 govern over scaled dimensions.

No.	Revisions

Date	15 May 2017
Updated Date	04 Oct 2022

Project No. UCONN-046

Phase CID

Project Title

University of Connecticut
 Campus Wayfinding

Sign Type G
Pedestrian Campus Kiosk

CID.44

TWO TWELVE

902 BROADWAY
 FLOOR 20
 NEW YORK, NY
 10010/6002
 212 254/6670 T
 212 254/6614 F

For Planning & Coordination Only –
 Not for Construction

This document and the entirety of its
 contents are property of 212/Harakawa
 Inc. and/or Two Twelve Associates, Inc.
 No part of this document shall be
 duplicated, disseminated, distributed
 or used for any purpose without
 express written permission.

Do not use for final construction. Sign
 fabricator to verify and be responsible
 for all dimensions and work conditions
 and inform this office of variations prior
 to performing work. Written dimensions
 govern over scaled dimensions.

No.	Revisions

Date 15 May 2017

Project No. UCONN-046

Phase CID

Project Title
 University of Connecticut
 Campus Wayfinding

Sign Type G
Pedestrian Campus Kiosk

CID.45

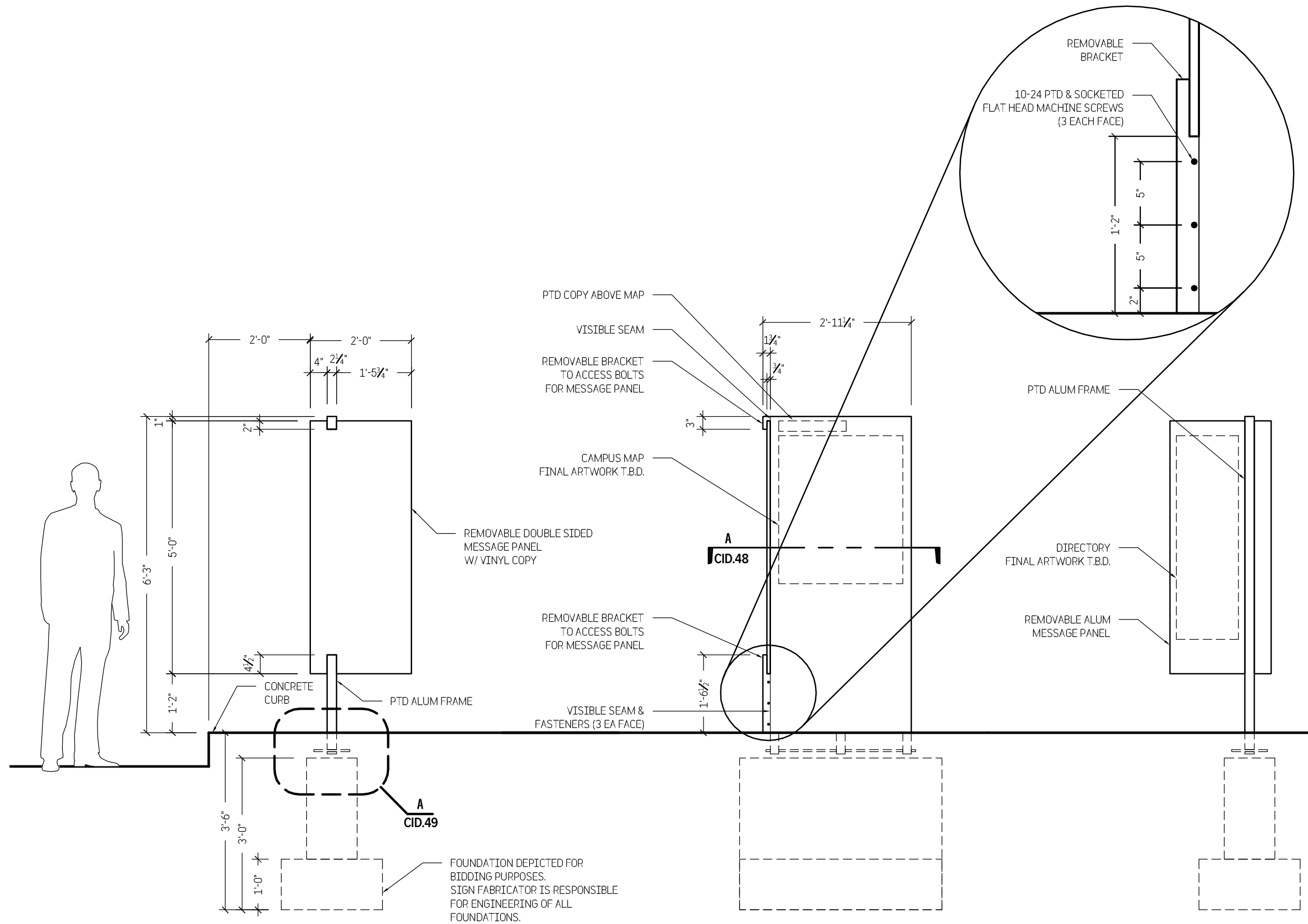

1 ELEVATION
 1/2" = 1'-0"

2 SIDE VIEW
 1/2" = 1'-0"

3 BACK VIEW
 1/2" = 1'-0"

TWO TWELVE

902 BROADWAY
 FLOOR 20
 NEW YORK, NY
 10010/6002
 212 254/6670 T
 212 254/6614 F

For Planning & Coordination Only –
 Not for Construction

This document and the entirety of its
 contents are property of 212/Harakawa
 Inc. and/or Two Twelve Associates, Inc.
 No part of this document shall be
 duplicated, disseminated, distributed
 or used for any purpose without
 express written permission.

Do not use for final construction. Sign
 fabricator to verify and be responsible
 for all dimensions and work conditions
 and inform this office of variations prior
 to performing work. Written dimensions
 govern over scaled dimensions.

No.	Revisions
-----	-----------

Date	15 May 2017
------	-------------

Project No.	UCONN-046
-------------	-----------

Phase	CID
-------	-----

Project Title	University of Connecticut Campus Wayfinding
---------------	--

**Sign Type G
 Pedestrian Campus Kiosk**

CID.46

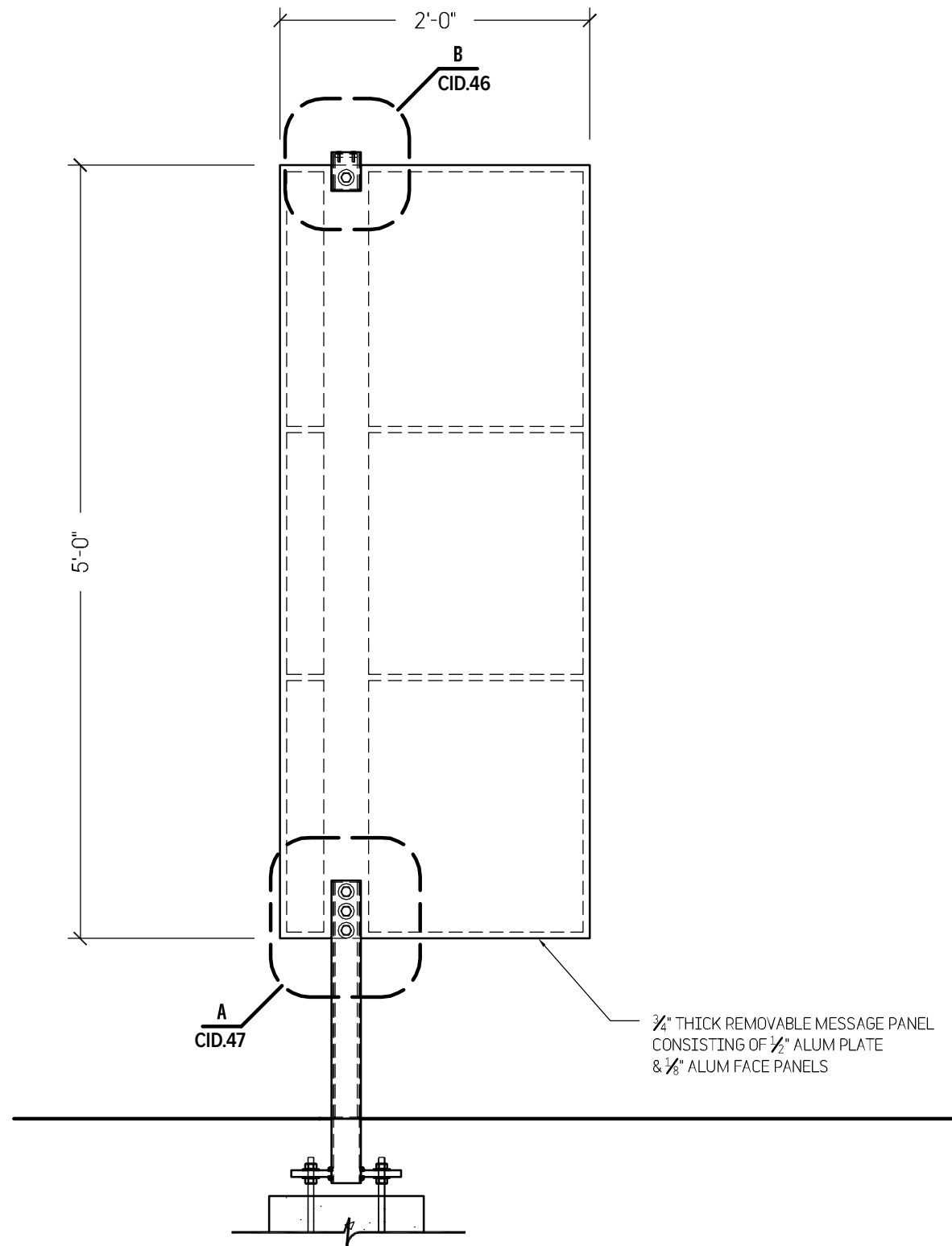

A SECTION
 1" = 1'-0"

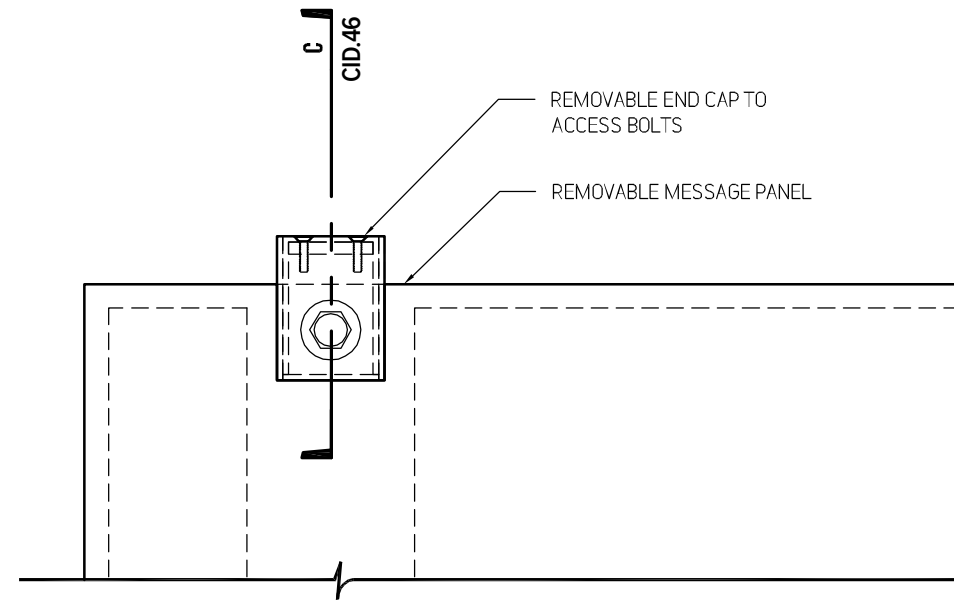

B SECTION
 3" = 1'-0"

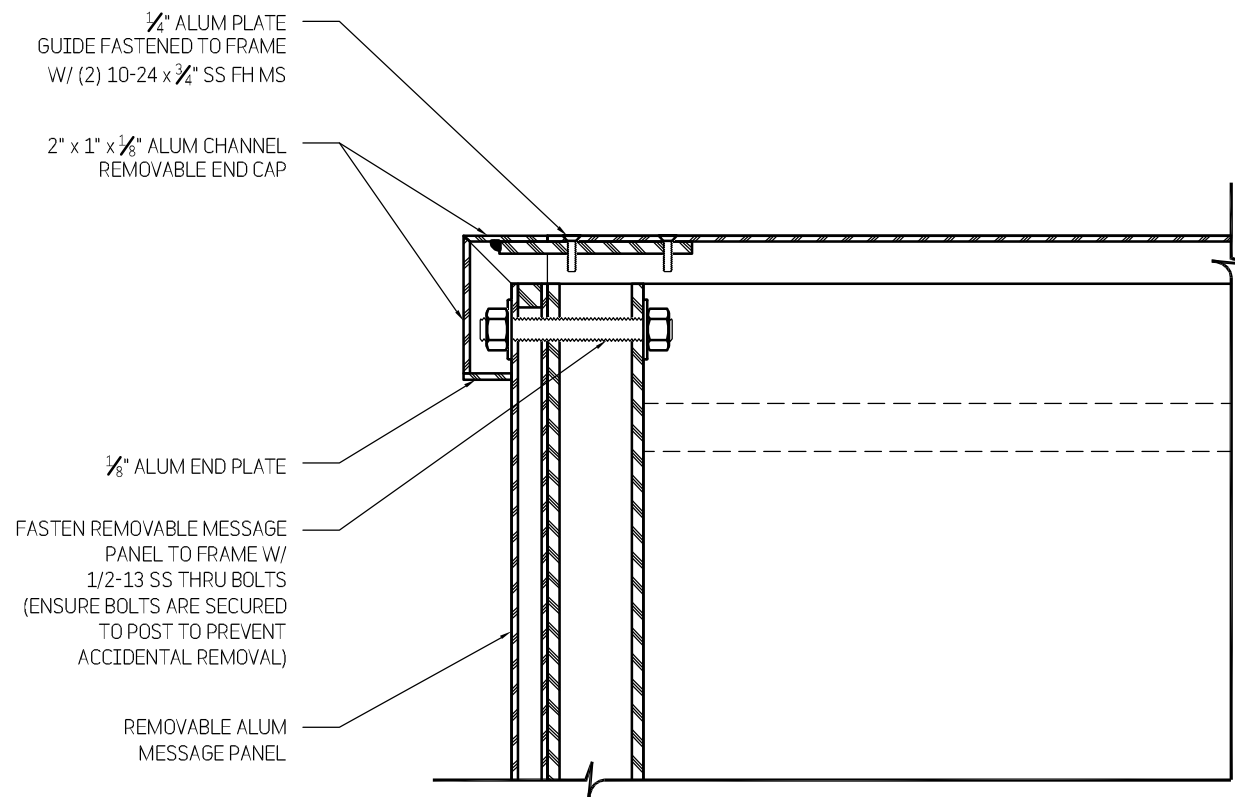

C SECTION
 3" = 1'-0"

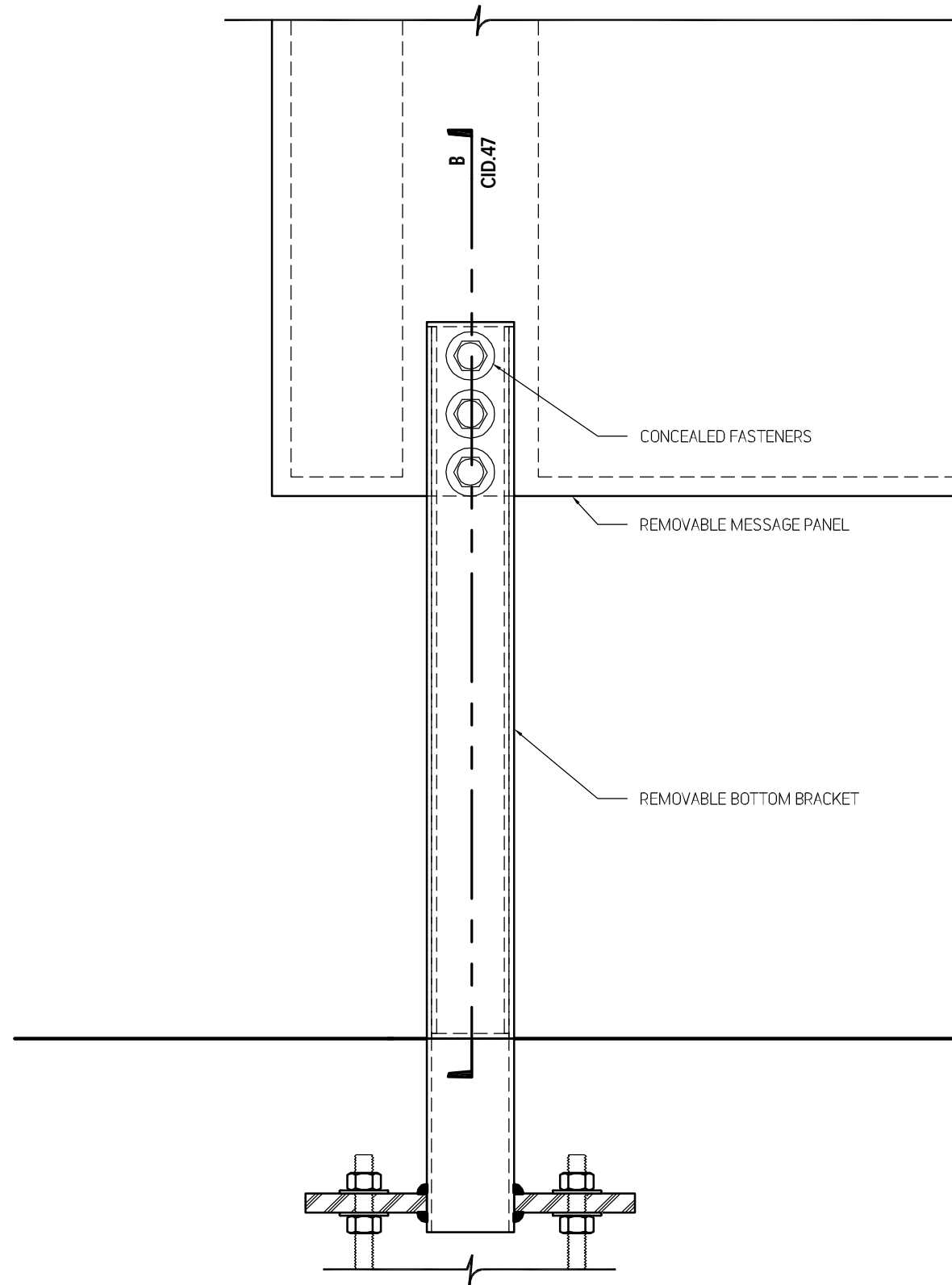

A SECTION
3" = 1'-0"

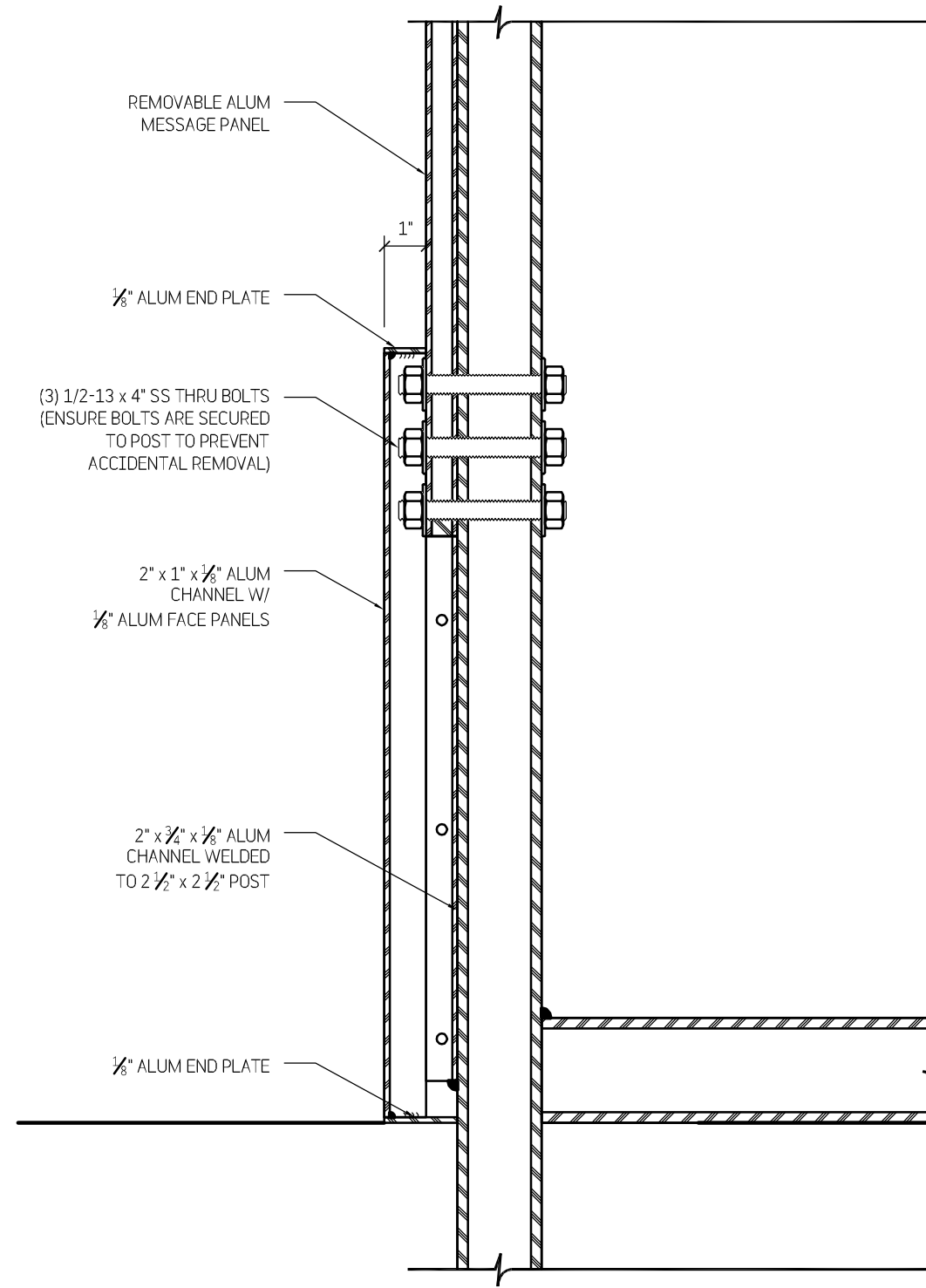

B SECTION
3" = 1'-0"

TWO TWELVE

902 BROADWAY
FLOOR 20
NEW YORK, NY
10010/6002
212 254/6670 T
212 254/6614 F

For Planning & Coordination Only –
Not for Construction

This document and the entirety of its contents are property of 212/Harakawa Inc. and/or Two Twelve Associates, Inc. No part of this document shall be duplicated, disseminated, distributed or used for any purpose without express written permission.

Do not use for final construction. Sign fabricator to verify and be responsible for all dimensions and work conditions and inform this office of variations prior to performing work. Written dimensions govern over scaled dimensions.

No.	Revisions

Date 15 May 2017

Project No. UCONN-046

Phase CID

Project Title
University of Connecticut
Campus Wayfinding

Sign Type G
Pedestrian Campus Kiosk

CID.47

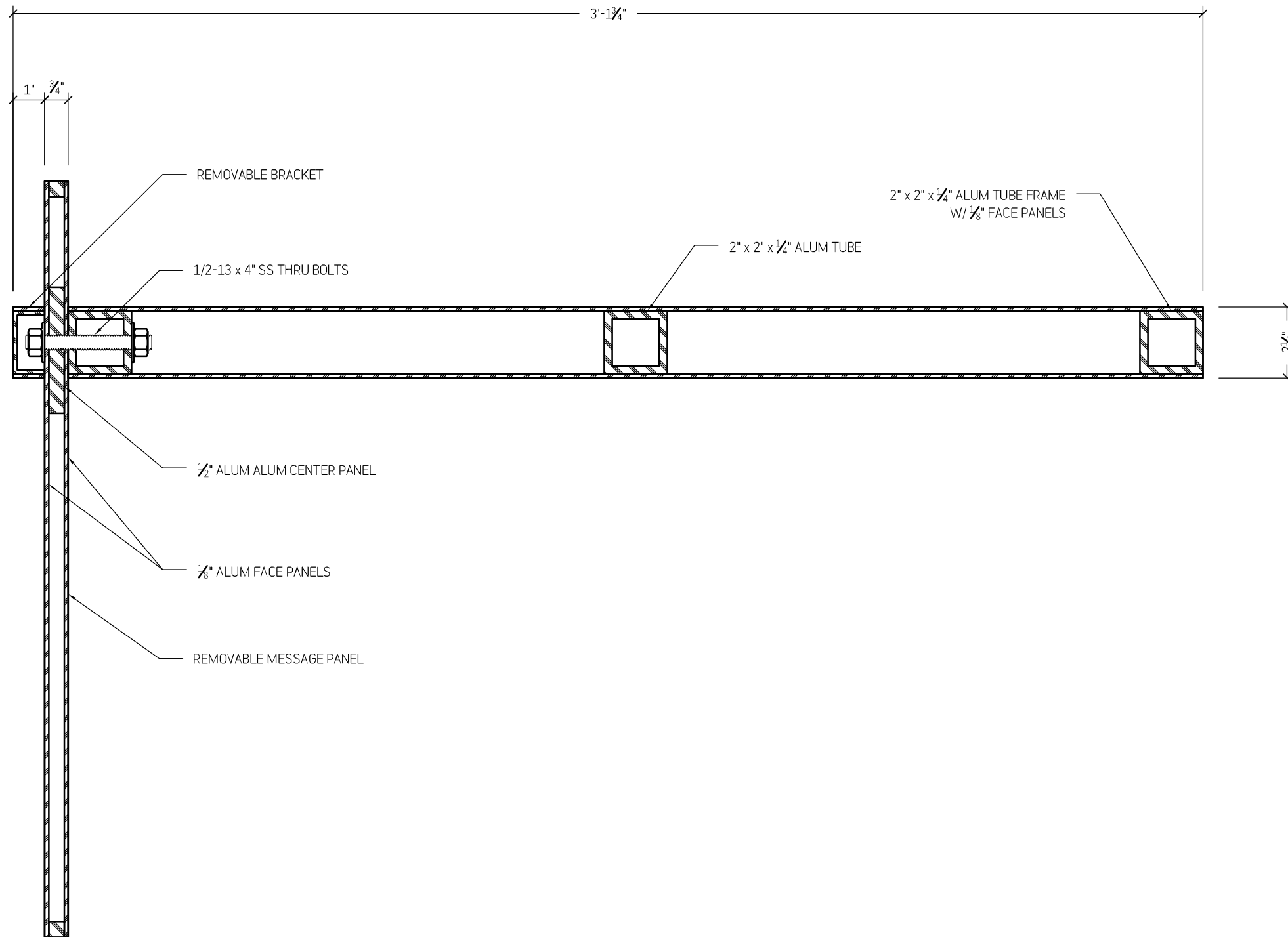

A SECTION
3" = 1'-0"

TWO TWELVE

902 BROADWAY
FLOOR 20
NEW YORK, NY
10010/6002
212 254/6670 T
212 254/6614 F

For Planning & Coordination Only –
Not for Construction

This document and the entirety of its contents are property of 212/Harakawa Inc. and/or Two Twelve Associates, Inc. No part of this document shall be duplicated, disseminated, distributed or used for any purpose without express written permission.

Do not use for final construction. Sign fabricator to verify and be responsible for all dimensions and work conditions and inform this office of variations prior to performing work. Written dimensions govern over scaled dimensions.

No.	Revisions

Date 15 May 2017

Project No. UCONN-046

Phase CID

Project Title
University of Connecticut
Campus Wayfinding

Sign Type G
Pedestrian Campus Kiosk

CID.48

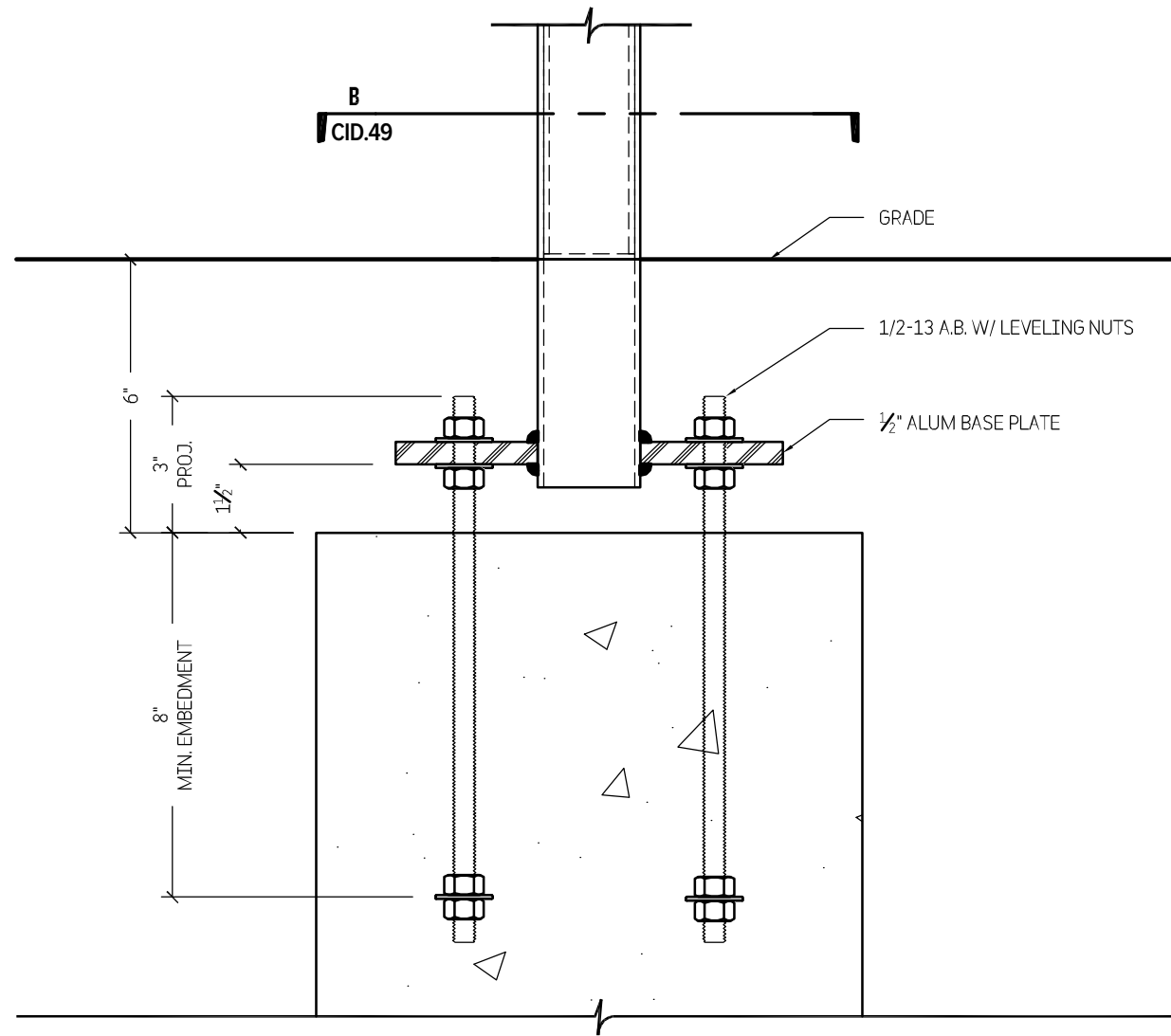

A SECTION
3" = 1'-0"

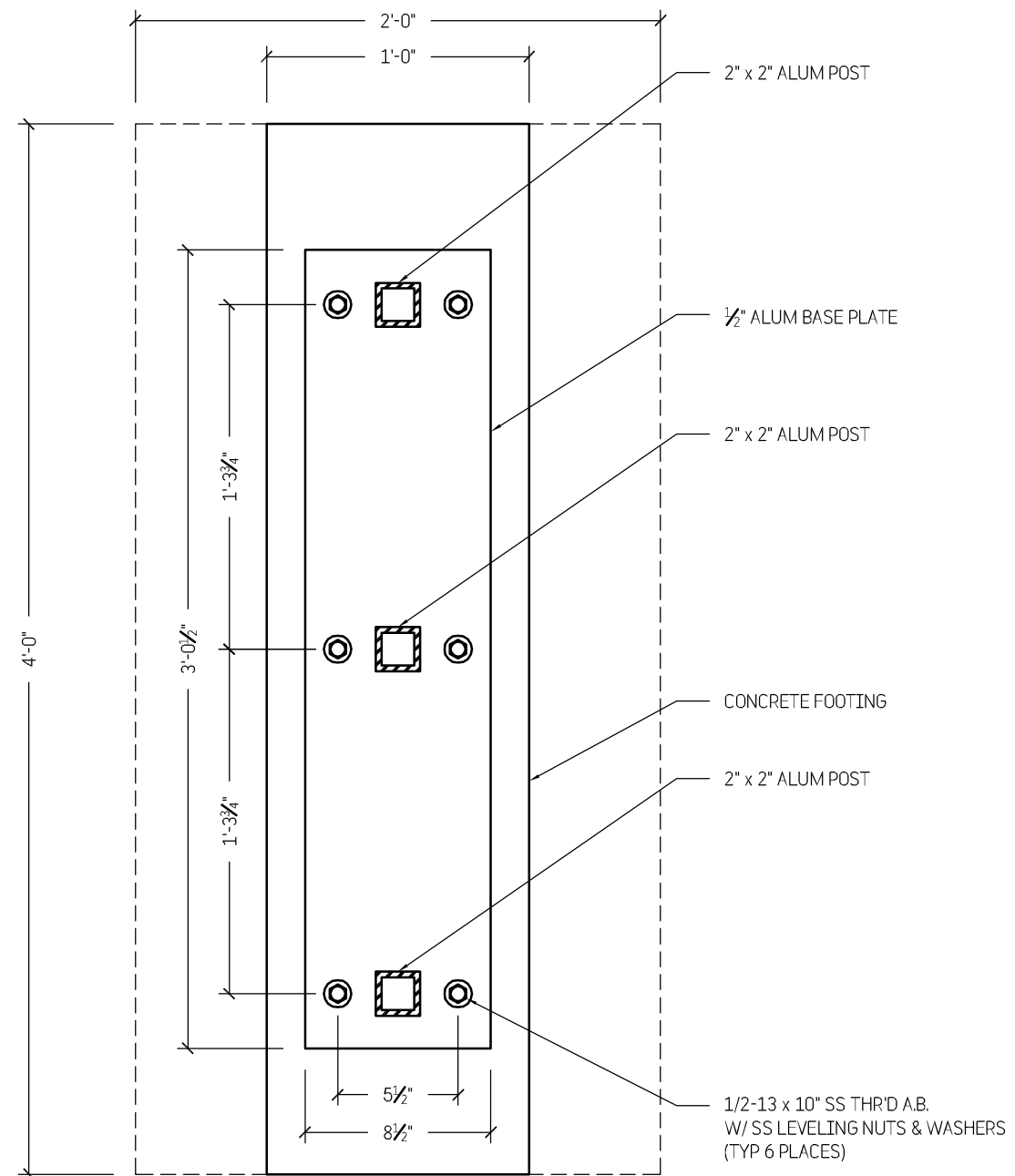

B SECTION
1 1/2" = 1'-0"

TWO TWELVE

902 BROADWAY
FLOOR 20
NEW YORK, NY
10010/6002
212 254/6670 T
212 254/6614 F

For Planning & Coordination Only –
Not for Construction

This document and the entirety of its
contents are property of 212/Harakawa
Inc. and/or Two Twelve Associates, Inc.
No part of this document shall be
duplicated, disseminated, distributed or
used for any purpose without
express written permission.

Do not use for final construction. Sign
fabricator to verify and be responsible
for all dimensions and work conditions
and inform this office of variations prior
to performing work. Written dimensions
govern over scaled dimensions.

No.	Revisions

Date 15 May 2017

Project No. UCONN-046

Phase CID

Project Title

University of Connecticut
Campus Wayfinding

Sign Type G
Pedestrian Campus Kiosk

CID.49

TWO TWELVE

902 BROADWAY
FLOOR 20
NEW YORK, NY
10010/6002
212 254/6670 T
212 254/6614 F

For Planning & Coordination Only –
Not for Construction

This document and the entirety of its contents are property of 212/Harakawa Inc. and/or Two Twelve Associates, Inc. No part of this document shall be duplicated, disseminated, distributed or used for any purpose without express written permission.

Do not use for final construction. Sign fabricator to verify and be responsible for all dimensions and work conditions and inform this office of variations prior to performing work. Written dimensions govern over scaled dimensions.

No. Revisions

Date 15 May 2017

Project No. UCONN-046

Phase CID

Project Title

University of Connecticut
Campus Wayfinding

Sign Type H1
Primary Pedestrian
Directional

CID.50

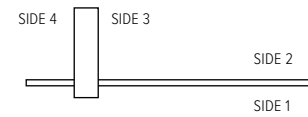

2 Plan - Sign Type H1
3/4" = 1'-0"

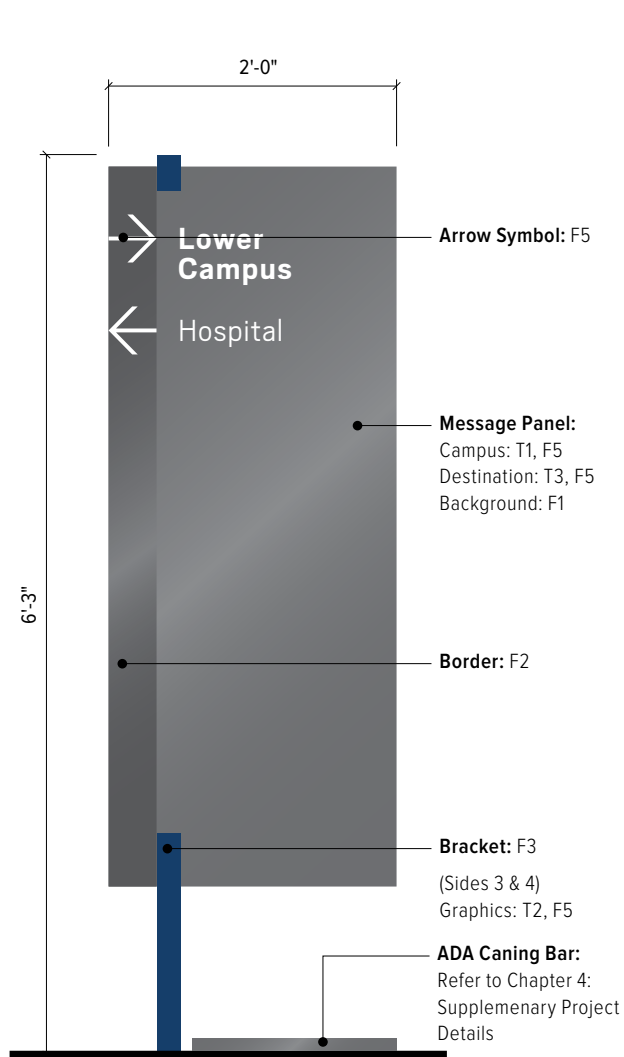

1 Elevation - Sign Type H1 (Side 1)
3/4" = 1'-0"

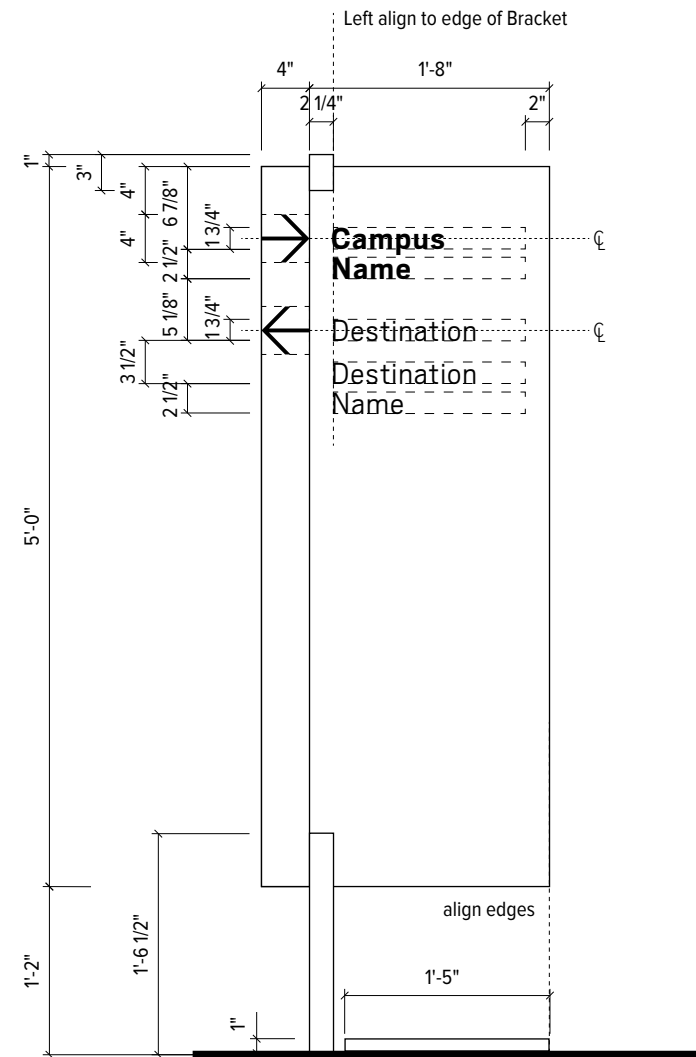

3 Graphic Layout - Sign Type H1 (Side 1)
3/4" = 1'-0"

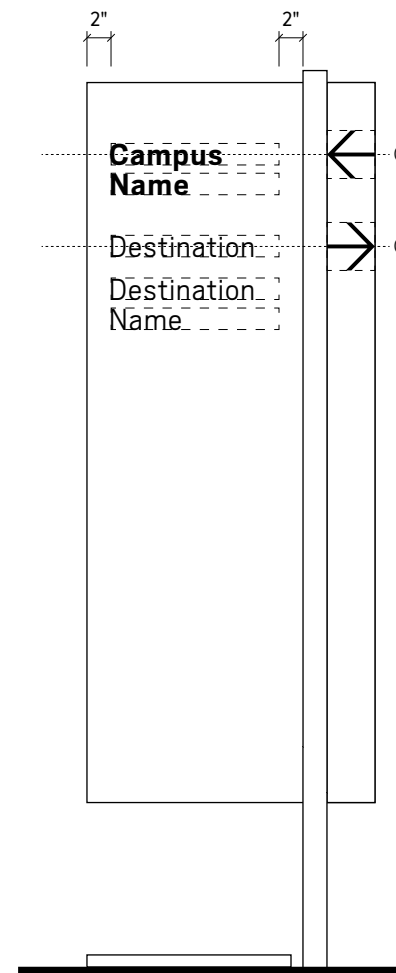

4 Graphic Layout - Sign Type H1 (Side 2)
3/4" = 1'-0"

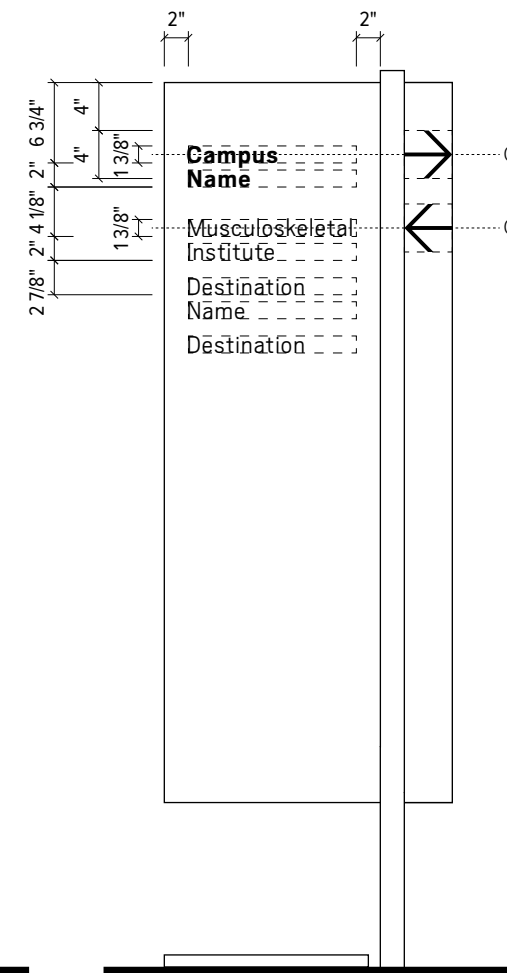

5 Alternate Graphic Layout - Sign Type H1 (Side 2)
3/4" = 1'-0"

Note:
Alternate Graphic
Layout occurs only
for Musculoskeletal
Institute.

TWO TWELVE

902 BROADWAY
 FLOOR 20
 NEW YORK, NY
 10010/6002
 212 254/6670 T
 212 254/6614 F

For Planning & Coordination Only –
 Not for Construction

This document and the entirety of its contents are property of 212/Harakawa Inc. and/or Two Twelve Associates, Inc. No part of this document shall be duplicated, disseminated, distributed or used for any purpose without express written permission.

Do not use for final construction. Sign fabricator to verify and be responsible for all dimensions and work conditions and inform this office of variations prior to performing work. Written dimensions govern over scaled dimensions.

No.	Revisions

Date	15 May 2017
------	-------------

Project No.	UCONN-046
-------------	-----------

Phase	CID
-------	-----

Project Title	
---------------	--

University of Connecticut	
Campus Wayfinding	

Sign Type H1
Primary Pedestrian
Directional

CID.51

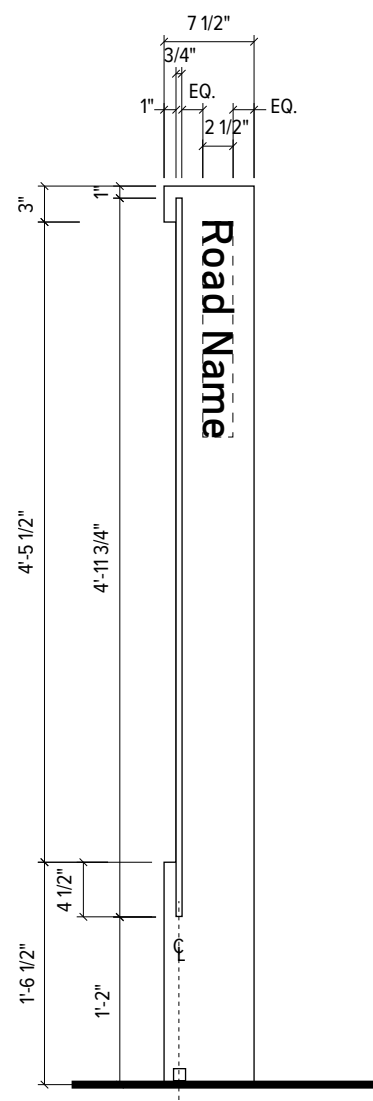

1 Side View - Sign Type H1 (Side 3)
 3/4" = 1'-0"

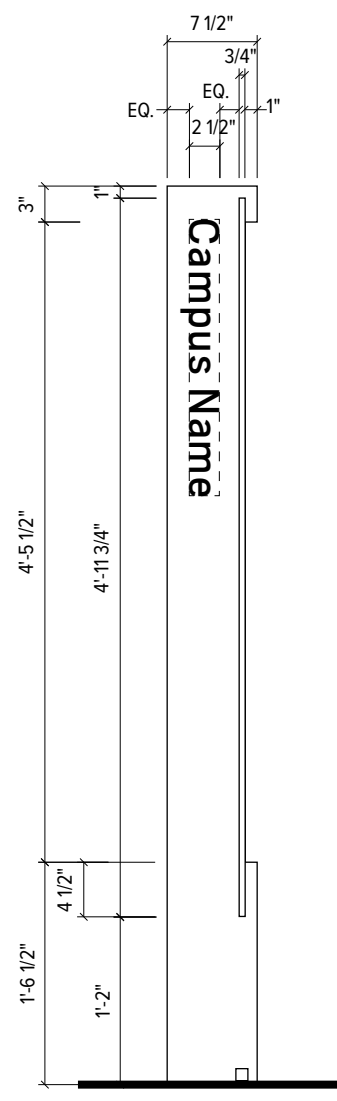

2 Side View - Sign Type H1 (Side 4)
 3/4" = 1'-0"

TWO TWELVE

902 BROADWAY
 FLOOR 20
 NEW YORK, NY
 10010/6002
 212 254/6670 T
 212 254/6614 F

For Planning & Coordination Only –
 Not for Construction

This document and the entirety of its
 contents are property of 212/Harakawa
 Inc. and/or Two Twelve Associates, Inc.
 No part of this document shall be
 duplicated, disseminated, distributed
 or used for any purpose without
 express written permission.

Do not use for final construction. Sign
 fabricator to verify and be responsible
 for all dimensions and work conditions
 and inform this office of variations prior
 to performing work. Written dimensions
 govern over scaled dimensions.

No.	Revisions
-----	-----------

Date	15 May 2017
------	-------------

Project No.	UCONN-046
-------------	-----------

Phase	CID
-------	-----

Project Title	University of Connecticut Campus Wayfinding
---------------	--

Sign Type H1
Primary Pedestrian
Directional

CID.52

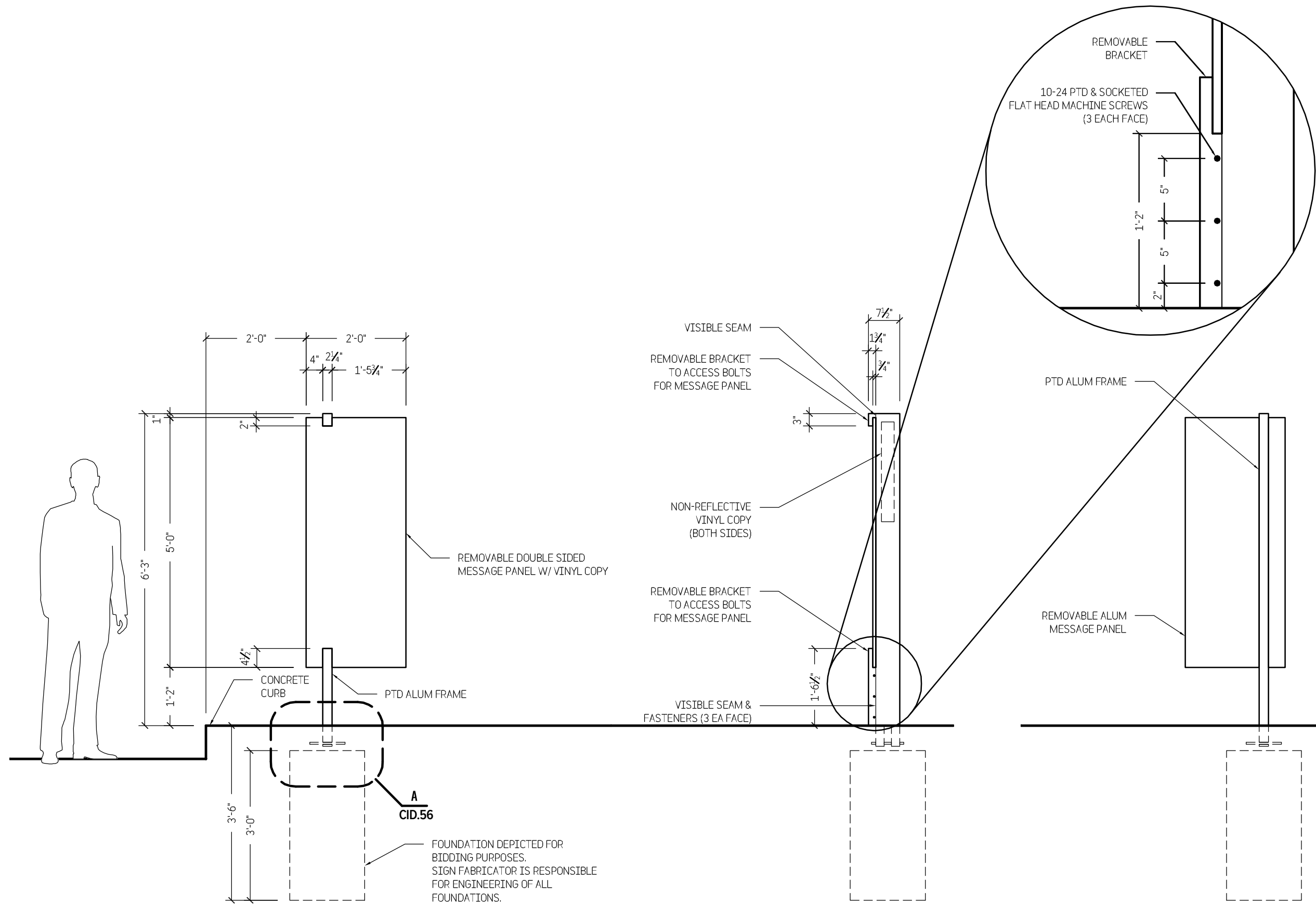

1 ELEVATION
 1/2" = 1'-0"

2 SIDE VIEW
 1/2" = 1'-0"

3 BACK VIEW
 1/2" = 1'-0"

A
 CID.56
 FOUNDATION DEPICTED FOR
 BIDDING PURPOSES.
 SIGN FABRICATOR IS RESPONSIBLE
 FOR ENGINEERING OF ALL
 FOUNDATIONS.

TWO TWELVE

902 BROADWAY
FLOOR 20
NEW YORK, NY
10010/6002
212 254/6670 T
212 254/6614 F

For Planning & Coordination Only –
Not for Construction

This document and the entirety of its
contents are property of 212/Harakawa
Inc. and/or Two Twelve Associates, Inc.
No part of this document shall be
duplicated, disseminated, distributed
or used for any purpose without
express written permission.

Do not use for final construction. Sign
fabricator to verify and be responsible
for all dimensions and work conditions
and inform this office of variations prior
to performing work. Written dimensions
govern over scaled dimensions.

No.	Revisions

Date 15 May 2017

Project No. UCONN-046

Phase CID

Project Title
University of Connecticut
Campus Wayfinding

Sign Type H1
Primary Pedestrian
Directional

CID.53

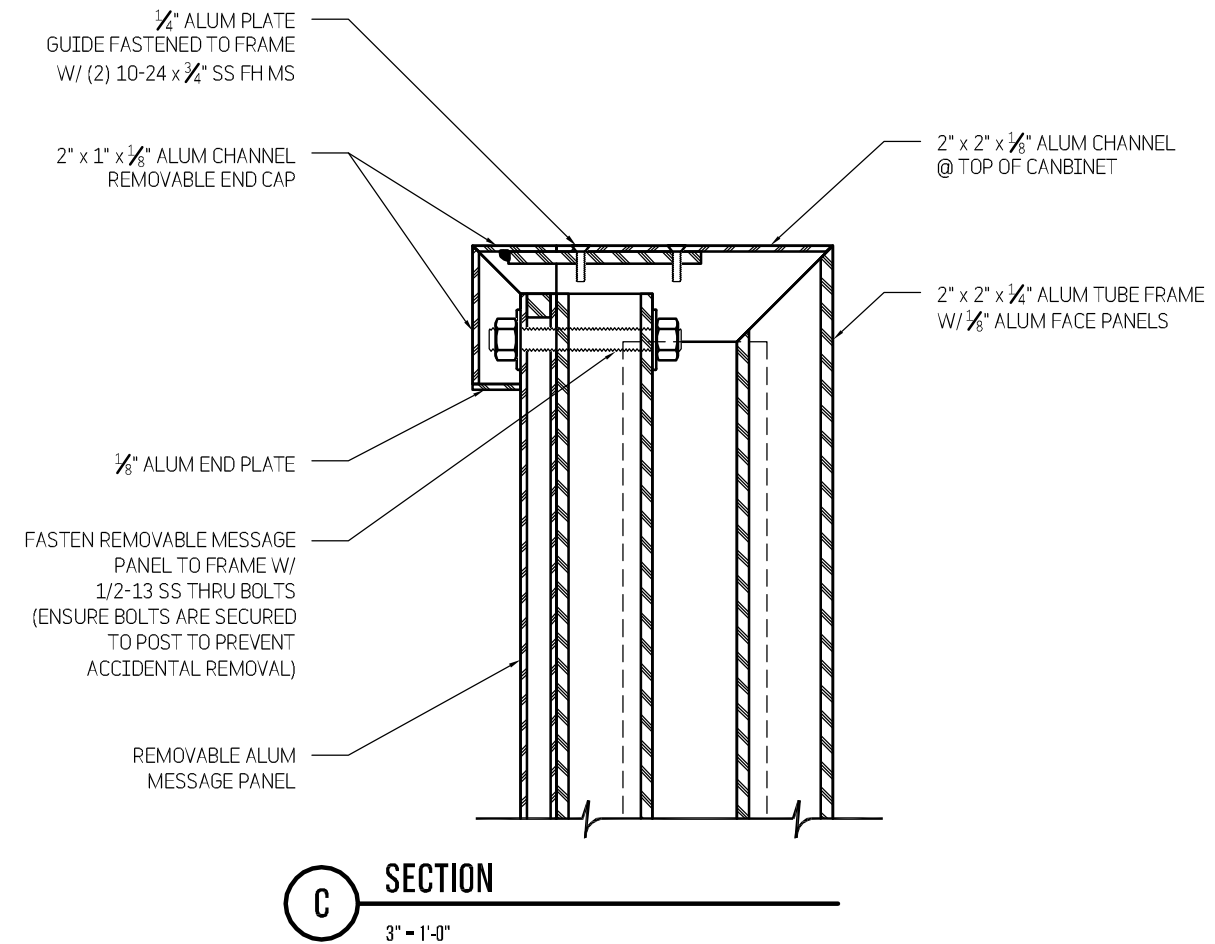
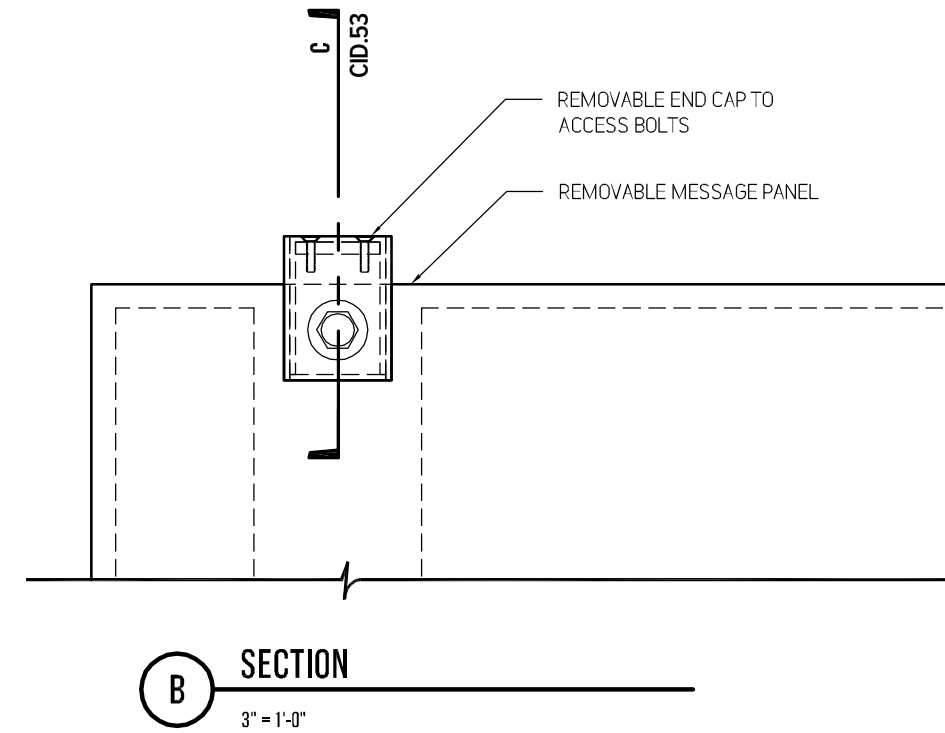
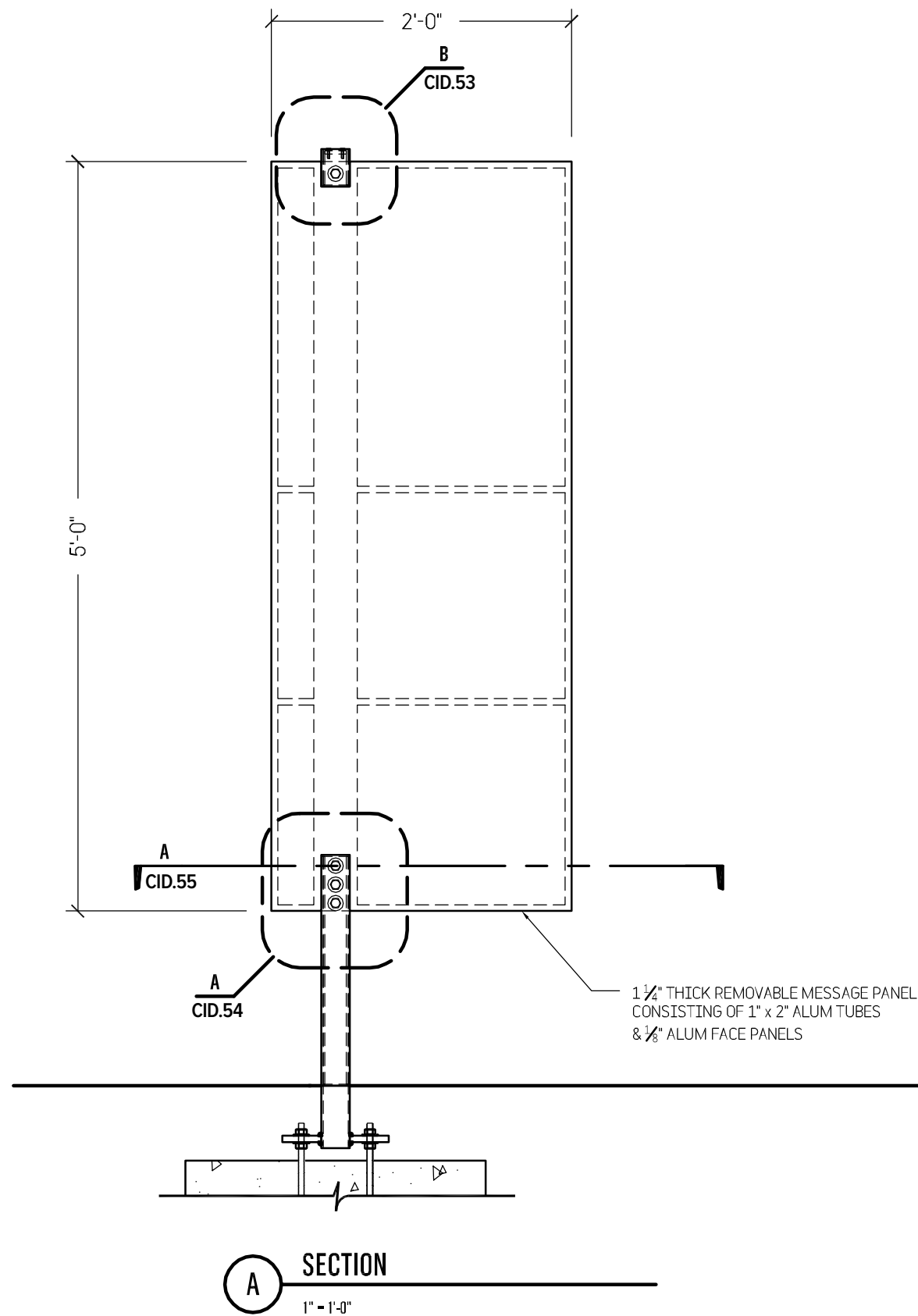

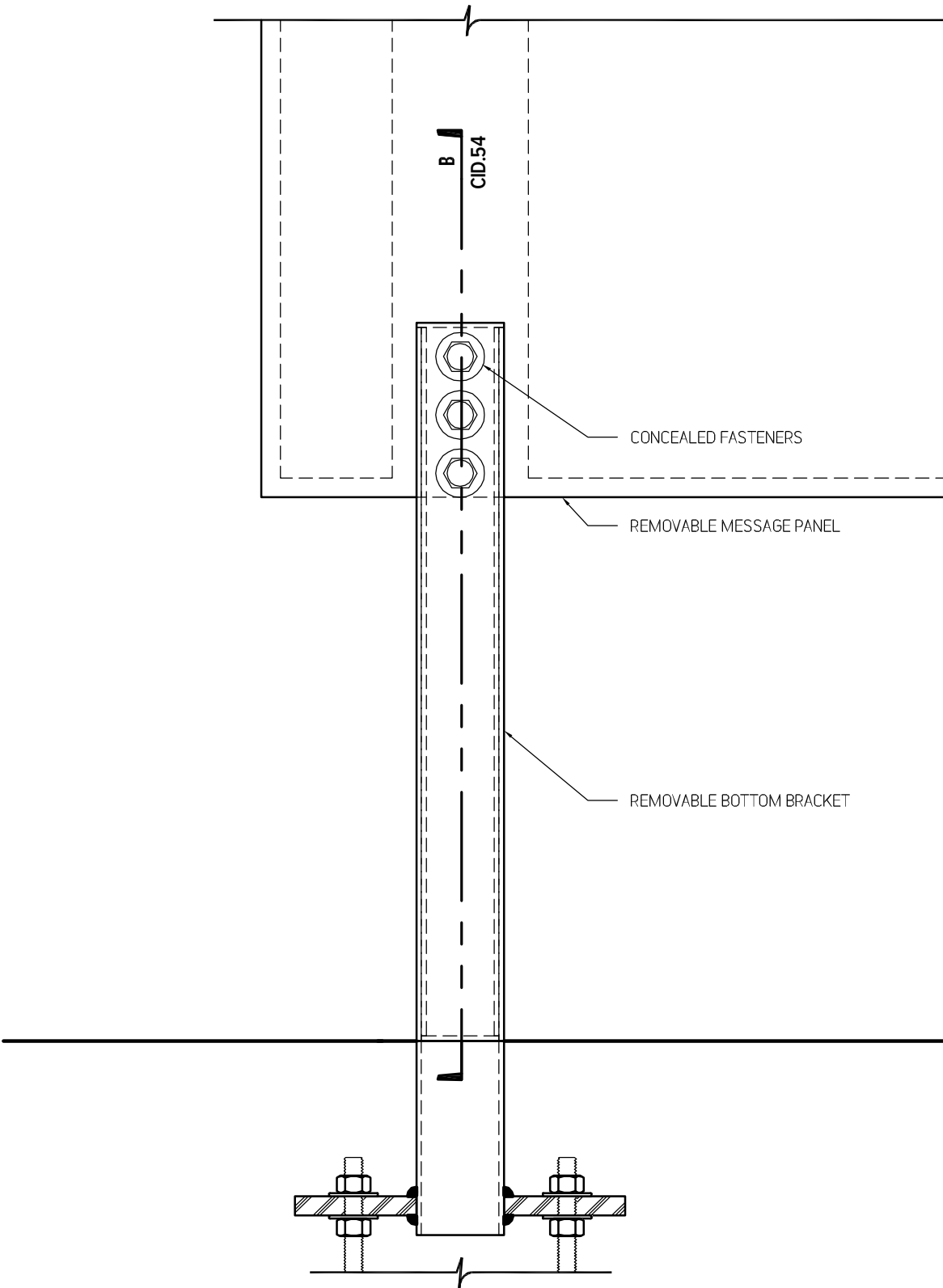

A SECTION
3" = 1'-0"

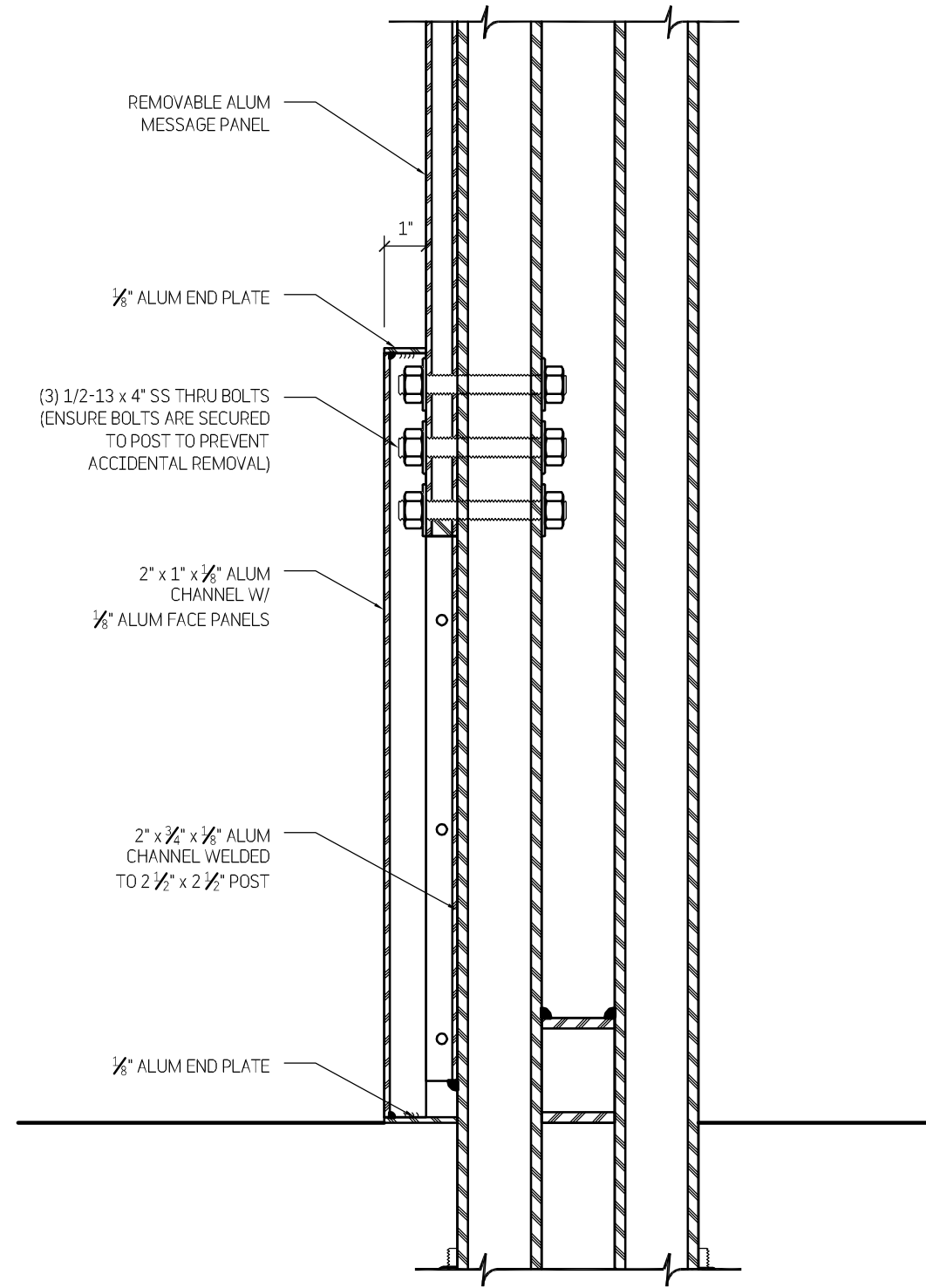

B SECTION
3" = 1'-0"

TWO TWELVE

902 BROADWAY
FLOOR 20
NEW YORK, NY
10010/6002
212 254/6670 T
212 254/6614 F

For Planning & Coordination Only –
Not for Construction

This document and the entirety of its contents are property of 212/Harakawa Inc. and/or Two Twelve Associates, Inc. No part of this document shall be duplicated, disseminated, distributed or used for any purpose without express written permission.

Do not use for final construction. Sign fabricator to verify and be responsible for all dimensions and work conditions and inform this office of variations prior to performing work. Written dimensions govern over scaled dimensions.

No.	Revisions

Date 15 May 2017

Project No. UCONN-046

Phase CID

Project Title
University of Connecticut
Campus Wayfinding

Sign Type H1
Primary Pedestrian
Directional

CID.54

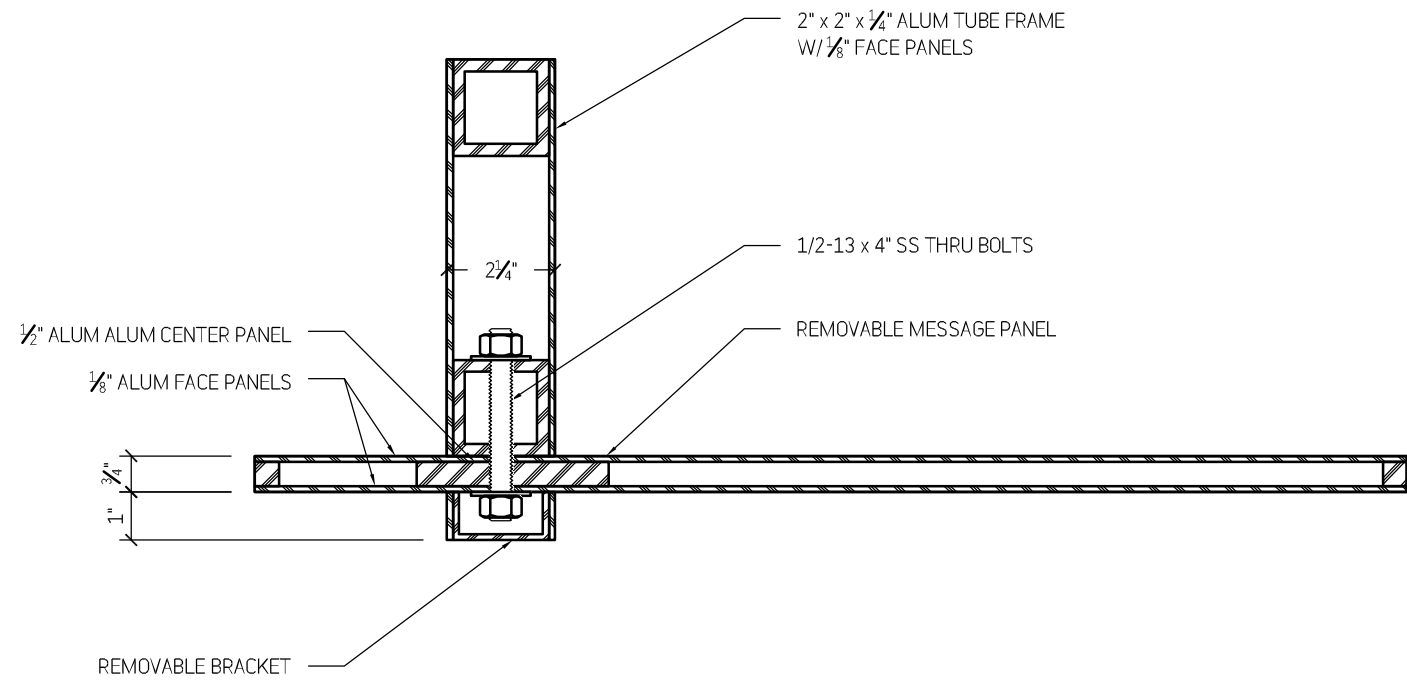

A SECTION
3" - 1'-0"

TWO TWELVE

902 BROADWAY
FLOOR 20
NEW YORK, NY
10010/6002
212 254/6670 T
212 254/6614 F

For Planning & Coordination Only –
Not for Construction

This document and the entirety of its contents are property of 212/Harakawa Inc. and/or Two Twelve Associates, Inc. No part of this document shall be duplicated, disseminated, distributed or used for any purpose without express written permission.

Do not use for final construction. Sign fabricator to verify and be responsible for all dimensions and work conditions and inform this office of variations prior to performing work. Written dimensions govern over scaled dimensions.

No.	Revisions
-----	-----------

Date 15 May 2017

Project No. UCONN-046

Phase CID

Project Title

University of Connecticut
Campus Wayfinding

**Sign Type H1
Primary Pedestrian
Directional**

CID.55

TWO TWELVE

902 BROADWAY
 FLOOR 20
 NEW YORK, NY
 10010/6002
 212 254/6670 T
 212 254/6614 F

For Planning & Coordination Only –
 Not for Construction

This document and the entirety of its contents are property of 212/Harakawa Inc. and/or Two Twelve Associates, Inc. No part of this document shall be duplicated, disseminated, distributed or used for any purpose without express written permission.

Do not use for final construction. Sign fabricator to verify and be responsible for all dimensions and work conditions and inform this office of variations prior to performing work. Written dimensions govern over scaled dimensions.

No.	Revisions

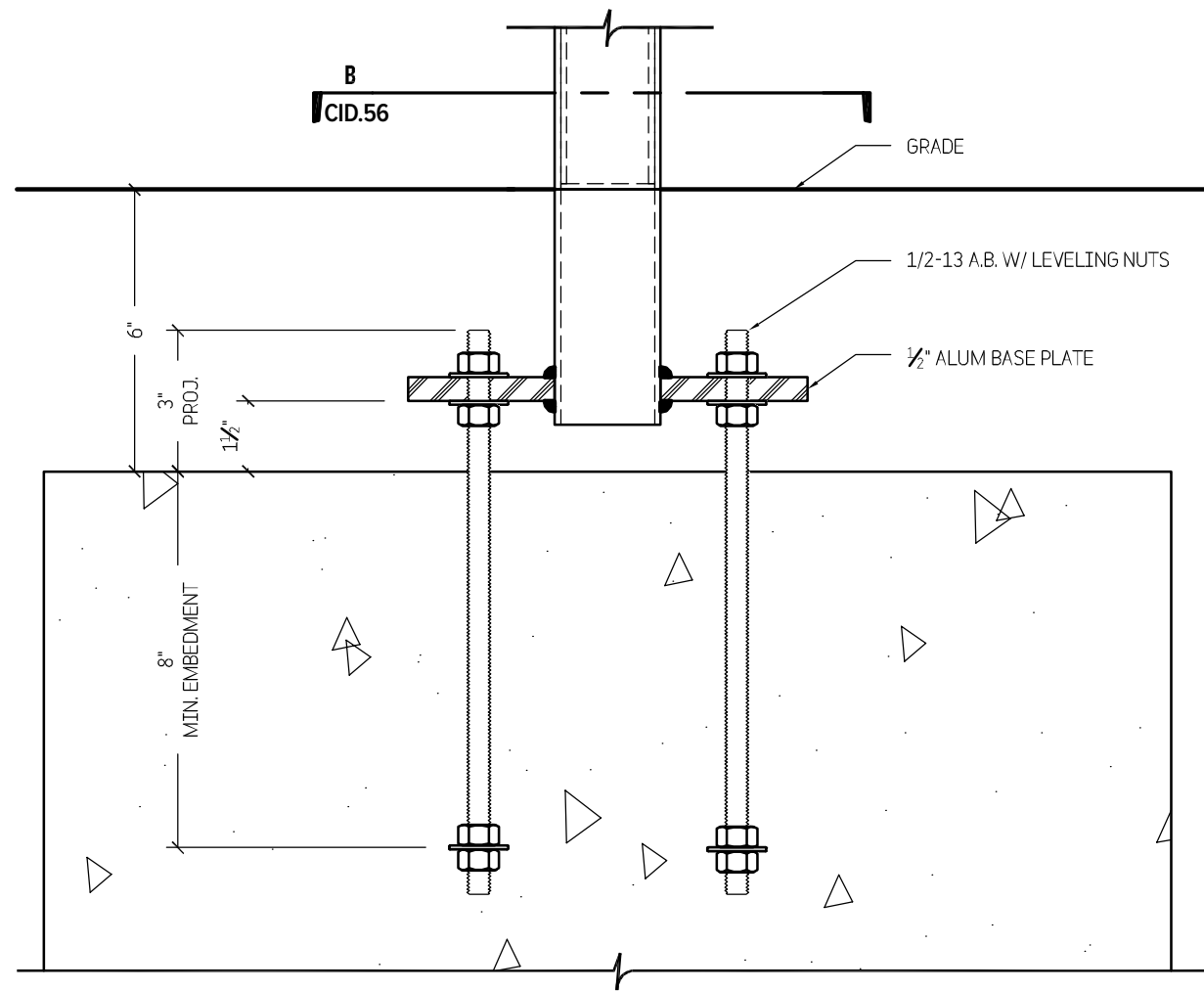

A SECTION
 3" = 1'-0"

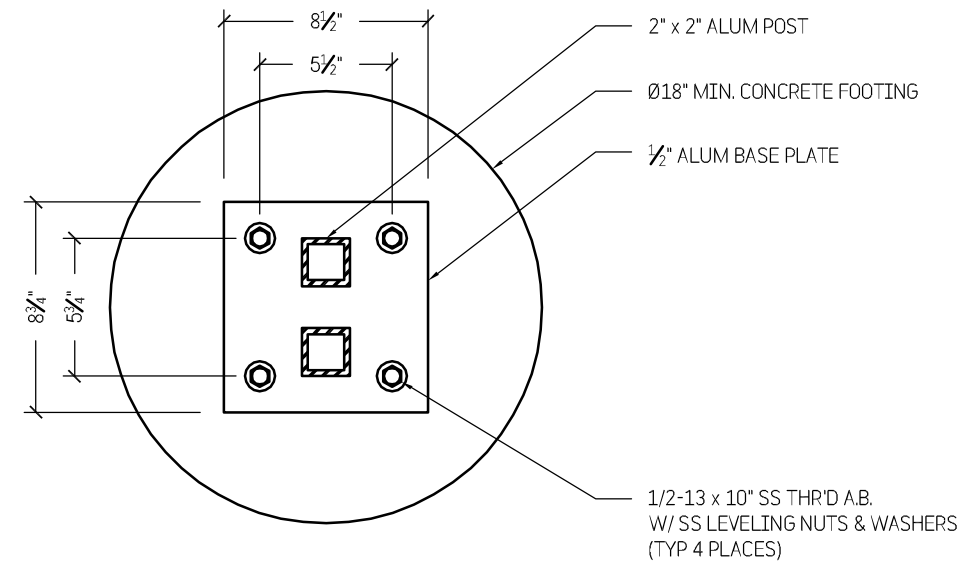

B SECTION
 1 1/2" = 1'-0"

Sign Type H1
Primary Pedestrian
Directional

CID.56

TWO TWELVE

902 BROADWAY
 FLOOR 20
 NEW YORK, NY
 10010/6002
 212 254/6670 T
 212 254/6614 F

For Planning & Coordination Only –
 Not for Construction

This document and the entirety of its contents are property of 212/Harakawa Inc. and/or Two Twelve Associates, Inc. No part of this document shall be duplicated, disseminated, distributed or used for any purpose without express written permission.

Do not use for final construction. Sign fabricator to verify and be responsible for all dimensions and work conditions and inform this office of variations prior to performing work. Written dimensions govern over scaled dimensions.

No.	Revisions
-----	-----------

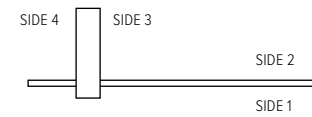

2 Plan - Sign Type H2
 3/4" = 1'-0"

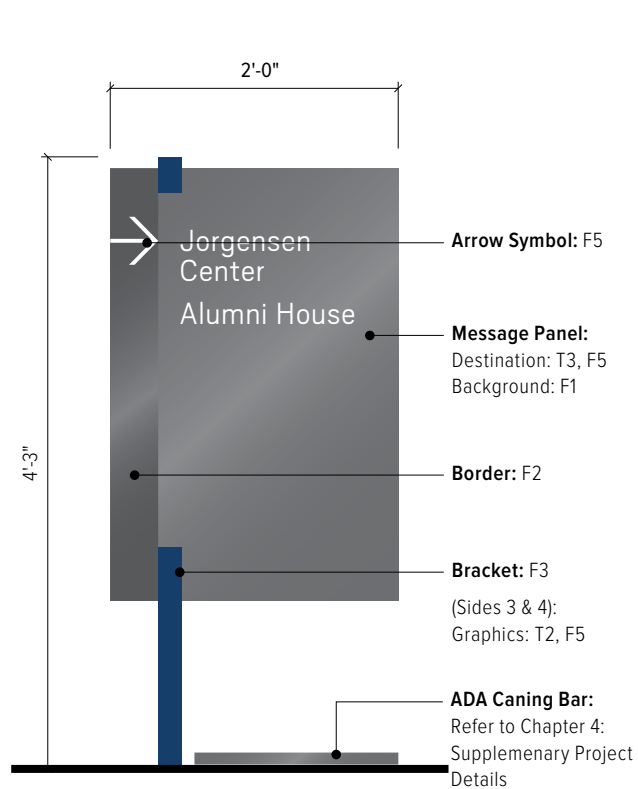

1 Elevation - Sign Type H2 (Side 1)
 3/4" = 1'-0"

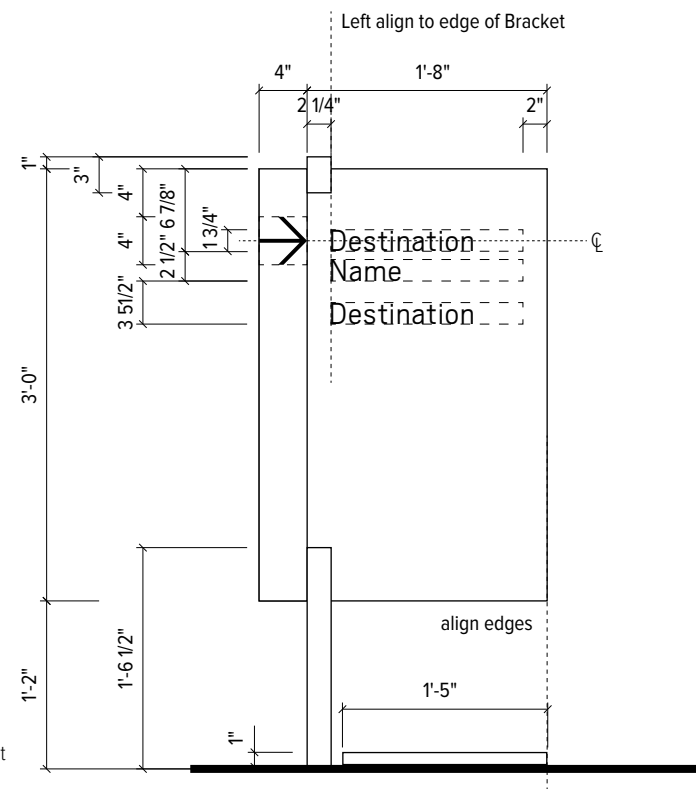

3 Graphic Layout - Sign Type H2 (Side 1)
 3/4" = 1'-0"

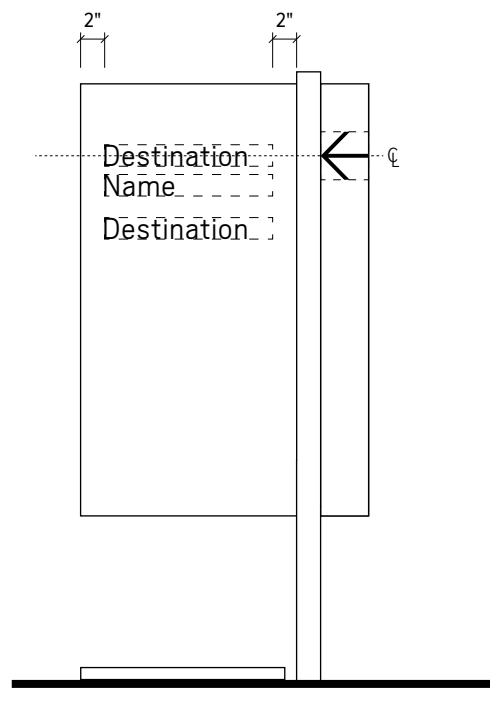

4 Graphic Layout - Sign Type H2 (Side 2)
 3/4" = 1'-0"

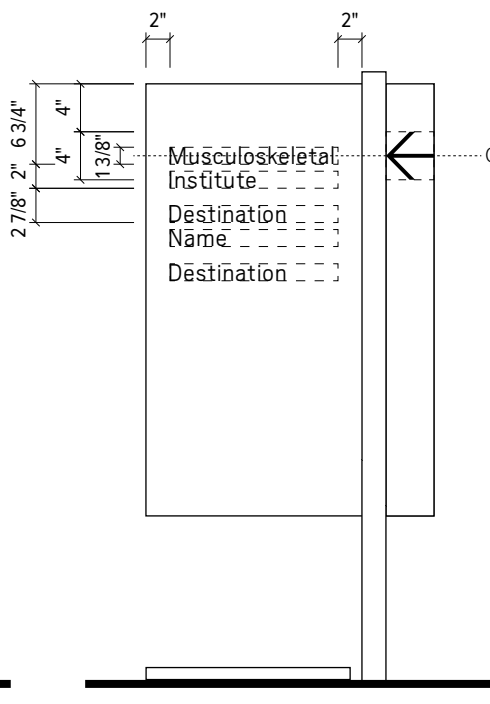

5 Alternate Graphic Layout - Sign Type H2 (Side 2)
 3/4" = 1'-0"

Note:
 Alternate Graphic Layout occurs only for Musculoskeletal Institute.

Date	15 May 2017
Project No.	UCONN-046
Phase	CID
Project Title	University of Connecticut Campus Wayfinding

Sign Type H2
Secondary Pedestrian
Directional

CID.57

TWO TWELVE

902 BROADWAY
 FLOOR 20
 NEW YORK, NY
 10010/6002
 212 254/6670 T
 212 254/6614 F

For Planning & Coordination Only –
 Not for Construction

This document and the entirety of its contents are property of 212/Harakawa Inc. and/or Two Twelve Associates, Inc. No part of this document shall be duplicated, disseminated, distributed or used for any purpose without express written permission.

Do not use for final construction. Sign fabricator to verify and be responsible for all dimensions and work conditions and inform this office of variations prior to performing work. Written dimensions govern over scaled dimensions.

No.	Revisions
-----	-----------

Date	15 May 2017
------	-------------

Project No.	UCONN-046
-------------	-----------

Phase	CID
-------	-----

Project Title	
---------------	--

University of Connecticut Campus Wayfinding	
--	--

**Sign Type H2
 Secondary Pedestrian
 Directional**

CID.58

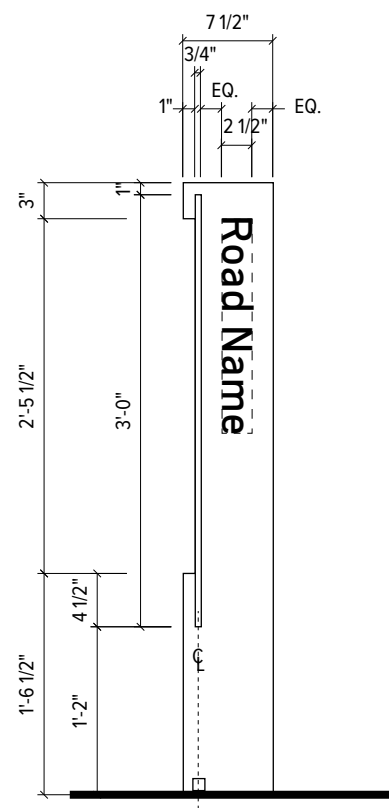

1 Side View - Sign Type H2 (Side 3)
 3/4" = 1'-0"

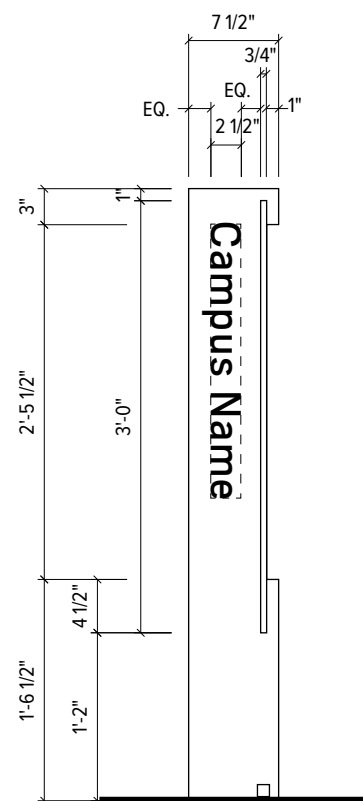

2 Side View - Sign Type H2 (Side 4)
 3/4" = 1'-0"

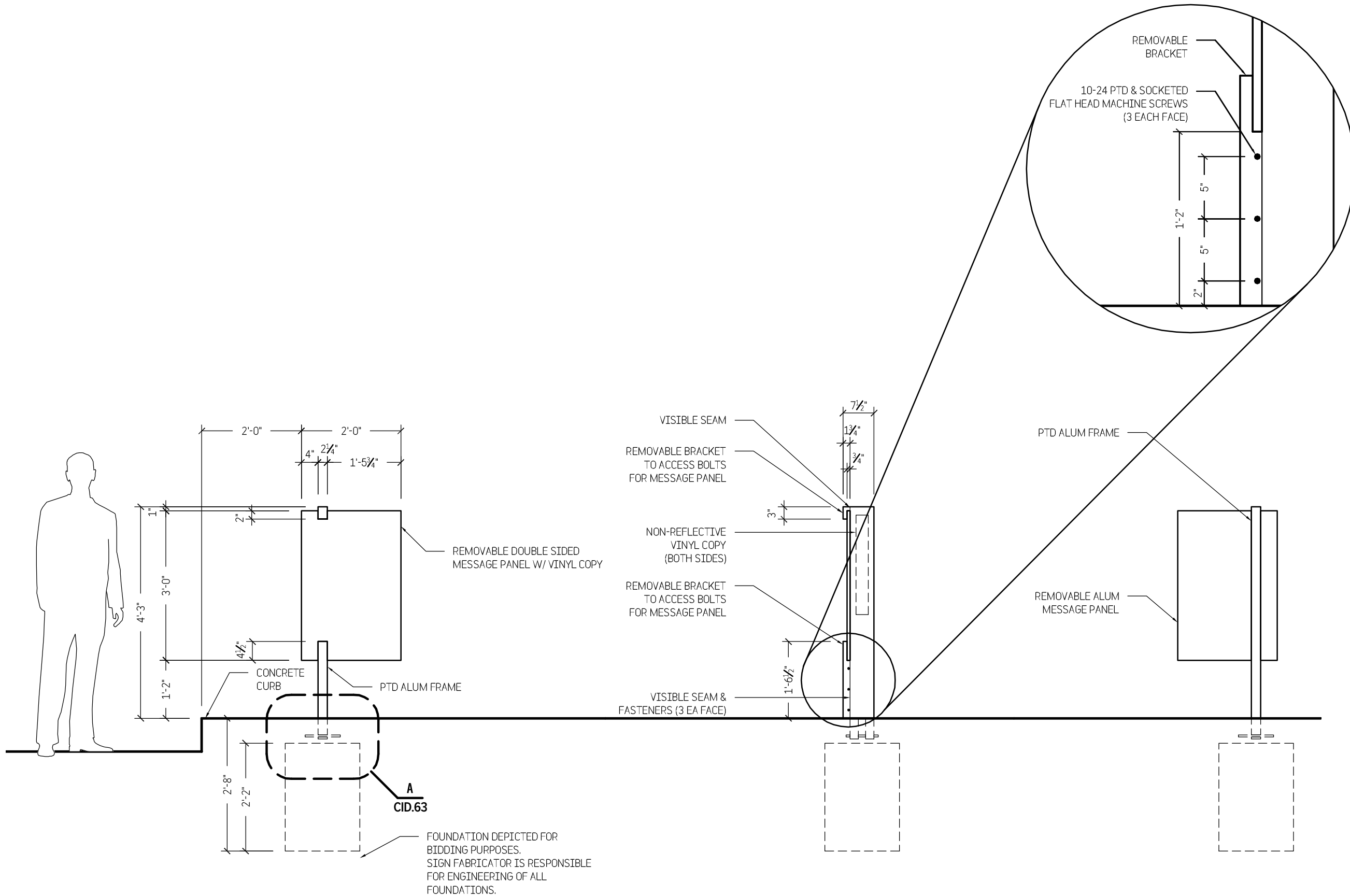

1 ELEVATION
1/2" = 1'-0"

2 SIDE VIEW
1/2" = 1'-0"

3 BACK VIEW
1/2" = 1'-0"

TWO TWELVE

902 BROADWAY
FLOOR 20
NEW YORK, NY
10010/6002
212 254/6670 T
212 254/6614 F

For Planning & Coordination Only –
Not for Construction

This document and the entirety of its contents are property of 212/Harakawa Inc. and/or Two Twelve Associates, Inc. No part of this document shall be duplicated, disseminated, distributed or used for any purpose without express written permission.

Do not use for final construction. Sign fabricator to verify and be responsible for all dimensions and work conditions and inform this office of variations prior to performing work. Written dimensions govern over scaled dimensions.

No.	Revisions
-----	-----------

Date	15 May 2017
Project No.	UCONN-046
Phase	CID
Project Title	University of Connecticut Campus Wayfinding

Sign Type H2
Secondary Pedestrian
Directional

CID.59

A
CID.63

FOUNDATION DEPICTED FOR
BIDDING PURPOSES.
SIGN FABRICATOR IS RESPONSIBLE
FOR ENGINEERING OF ALL
FOUNDATIONS.

TWO TWELVE

902 BROADWAY
 FLOOR 20
 NEW YORK, NY
 10010/6002
 212 254/6670 T
 212 254/6614 F

For Planning & Coordination Only –
 Not for Construction

This document and the entirety of its
 contents are property of 212/Harakawa
 Inc. and/or Two Twelve Associates, Inc.
 No part of this document shall be
 duplicated, disseminated, distributed
 or used for any purpose without
 express written permission.

Do not use for final construction. Sign
 fabricator to verify and be responsible
 for all dimensions and work conditions
 and inform this office of variations prior
 to performing work. Written dimensions
 govern over scaled dimensions.

No.	Revisions

Date 15 May 2017

Project No. UCONN-046

Phase CID

Project Title
 University of Connecticut
 Campus Wayfinding

**Sign Type H2
 Secondary Pedestrian
 Directional**

CID.60

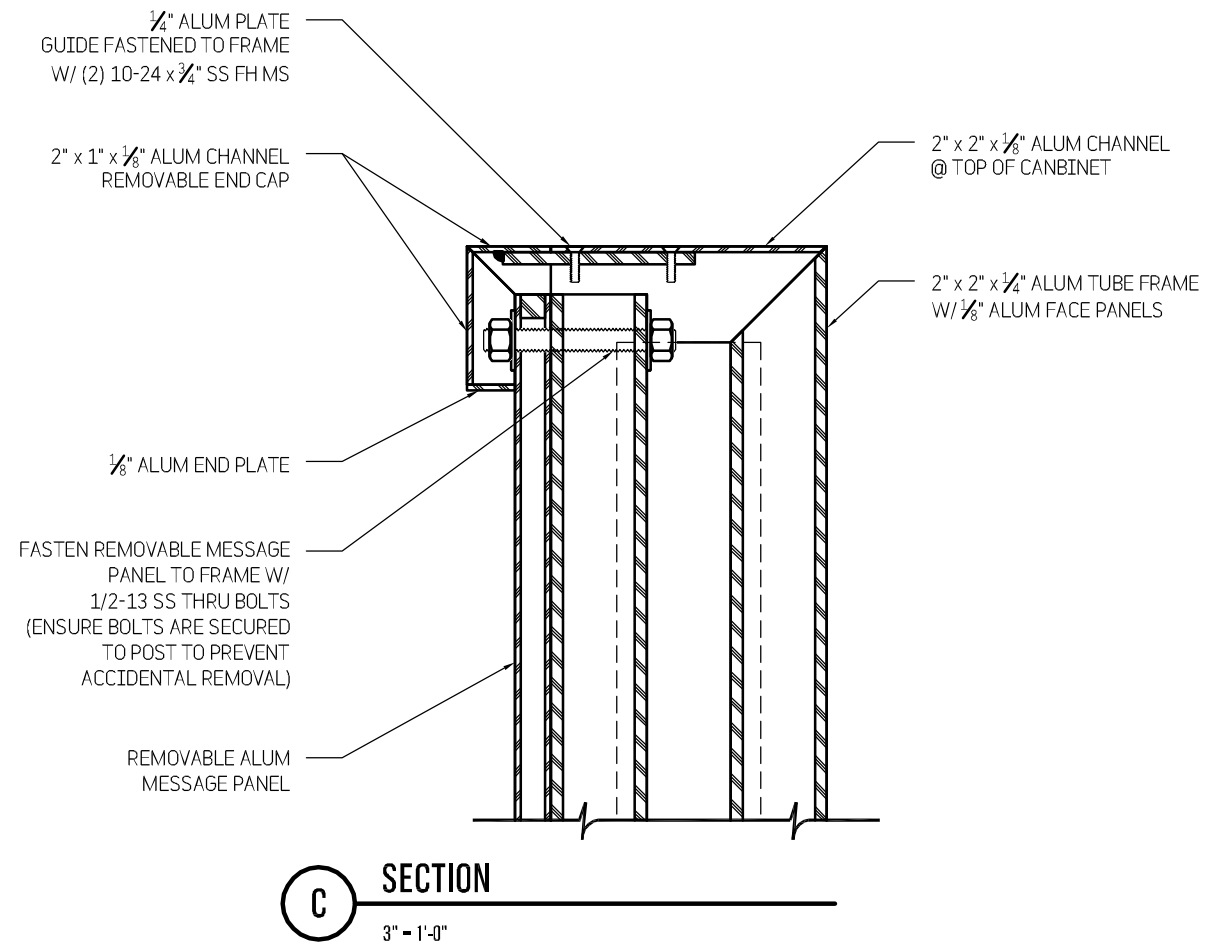
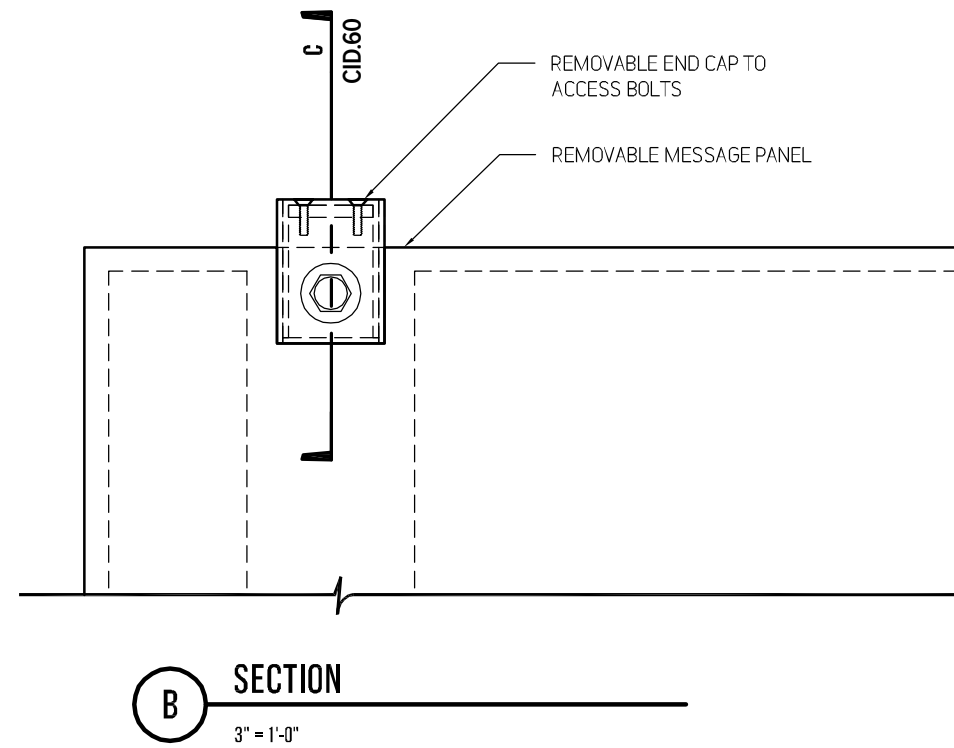
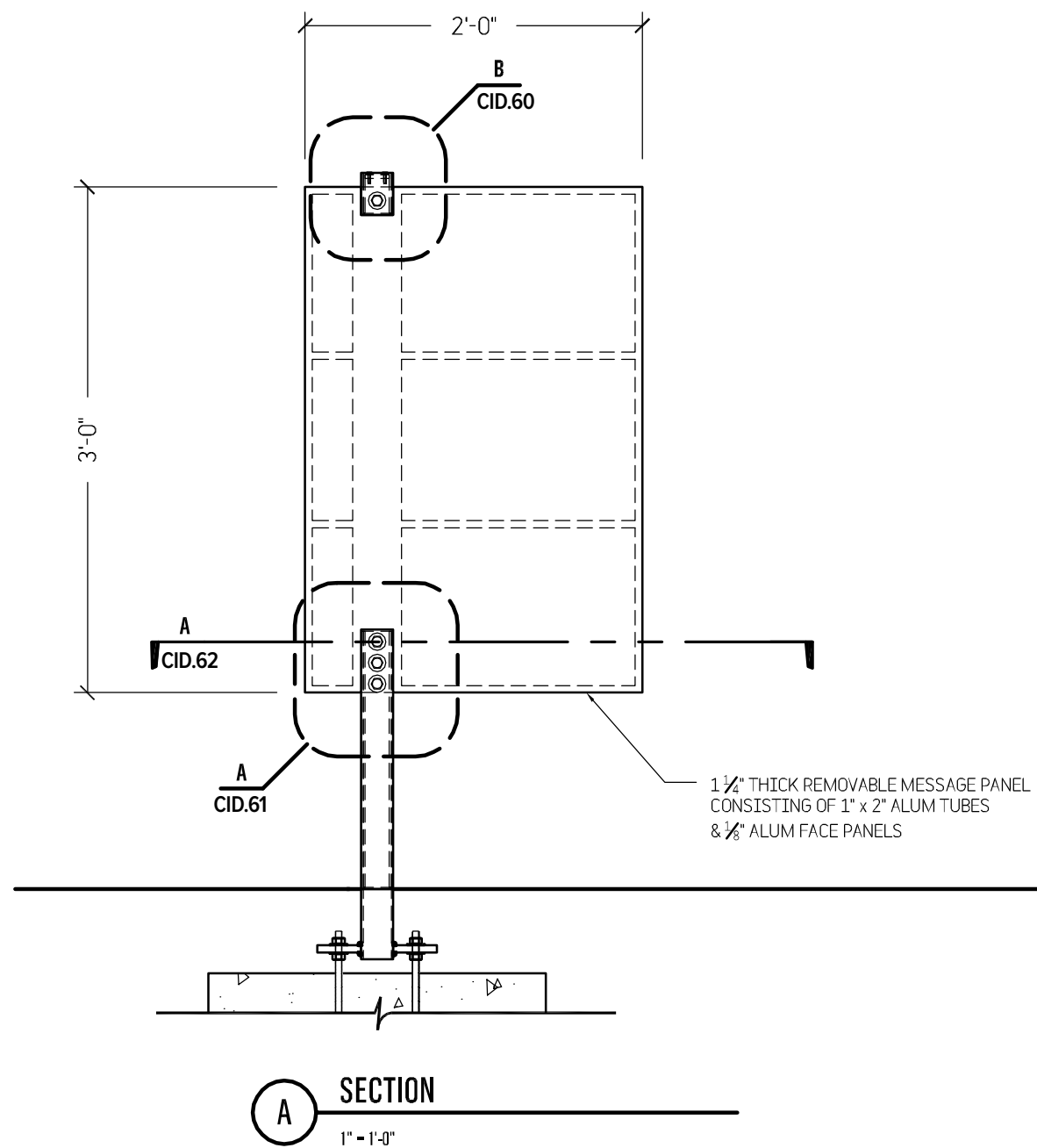

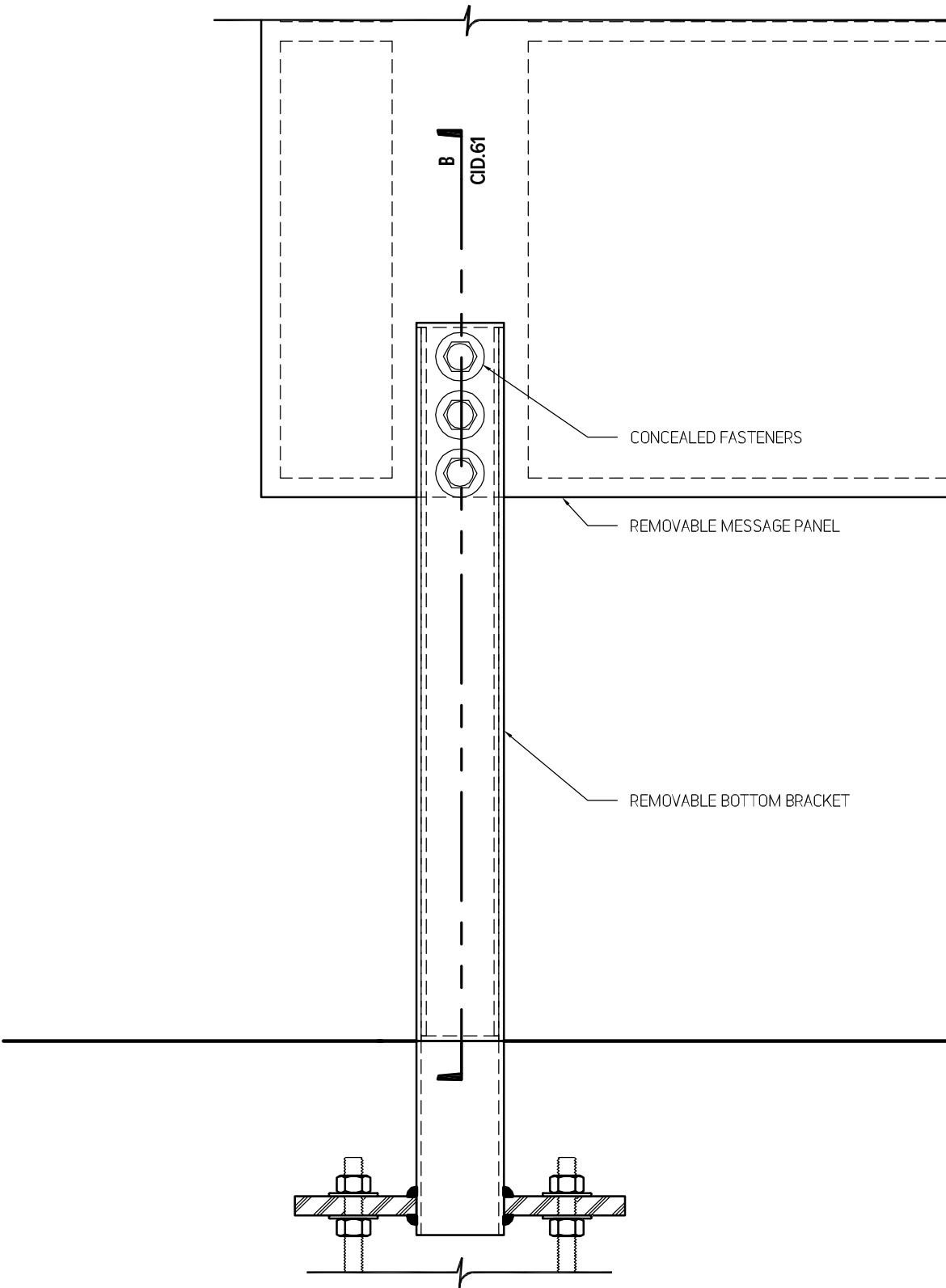

A SECTION
3" = 1'-0"

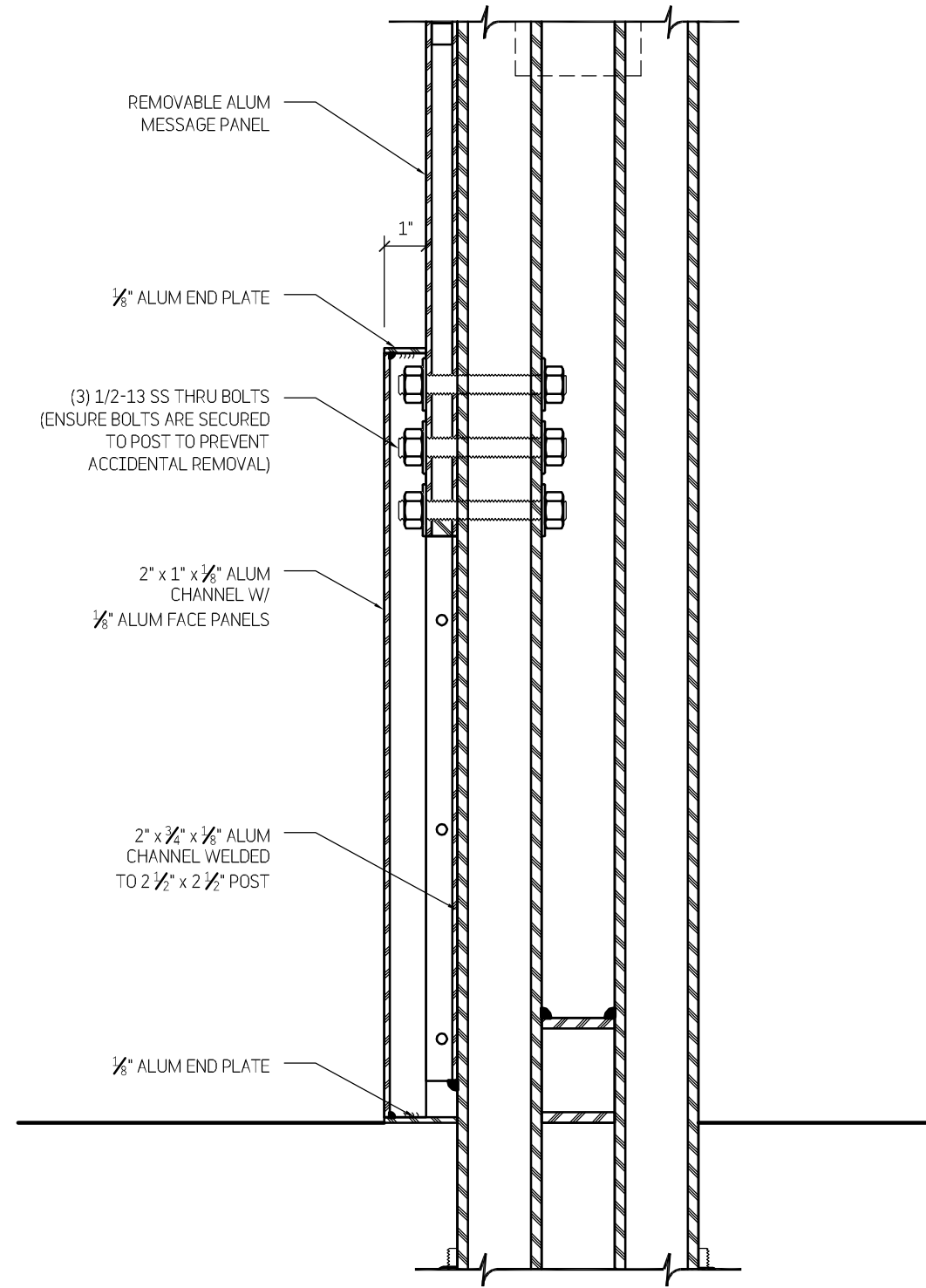

B SECTION
3" = 1'-0"

TWO TWELVE

902 BROADWAY
FLOOR 20
NEW YORK, NY
10010/6002
212 254/6670 T
212 254/6614 F

For Planning & Coordination Only –
Not for Construction

This document and the entirety of its contents are property of 212/Harakawa Inc. and/or Two Twelve Associates, Inc. No part of this document shall be duplicated, disseminated, distributed or used for any purpose without express written permission.

Do not use for final construction. Sign fabricator to verify and be responsible for all dimensions and work conditions and inform this office of variations prior to performing work. Written dimensions govern over scaled dimensions.

No.	Revisions

Date 15 May 2017

Project No. UCONN-046

Phase CID

Project Title
University of Connecticut
Campus Wayfinding

Sign Type H2
Secondary Pedestrian
Directional

CID.61

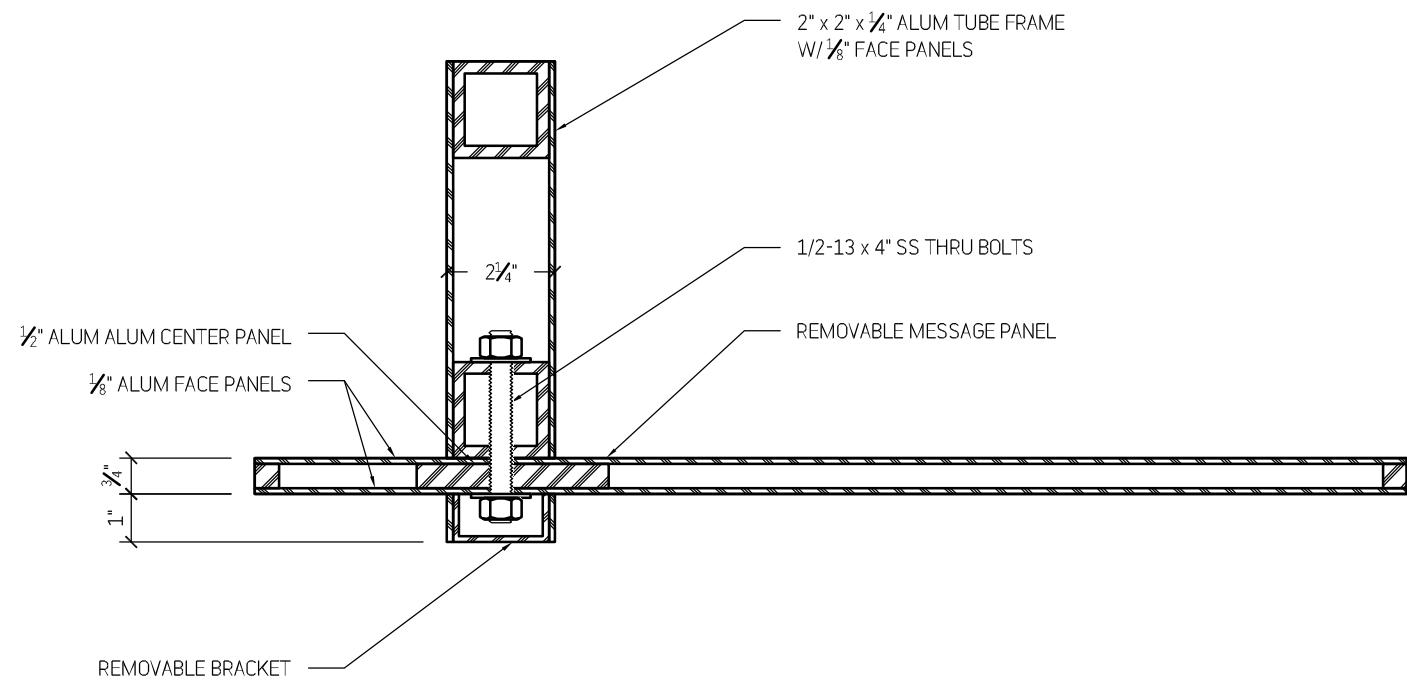

A SECTION
3" - 1'-0"

TWO TWELVE

902 BROADWAY
FLOOR 20
NEW YORK, NY
10010/6002
212 254/6670 T
212 254/6614 F

For Planning & Coordination Only –
Not for Construction

This document and the entirety of its contents are property of 212/Harakawa Inc. and/or Two Twelve Associates, Inc. No part of this document shall be duplicated, disseminated, distributed or used for any purpose without express written permission.

Do not use for final construction. Sign fabricator to verify and be responsible for all dimensions and work conditions and inform this office of variations prior to performing work. Written dimensions govern over scaled dimensions.

No.	Revisions

Date 15 May 2017

Project No. UCONN-046

Phase CID

Project Title

University of Connecticut
Campus Wayfinding

**Sign Type H2
Secondary Pedestrian
Directional**

CID.62

TWO TWELVE

902 BROADWAY
 FLOOR 20
 NEW YORK, NY
 10010/6002
 212 254/6670 T
 212 254/6614 F

For Planning & Coordination Only –
 Not for Construction

This document and the entirety of its contents are property of 212/Harakawa Inc. and/or Two Twelve Associates, Inc. No part of this document shall be duplicated, disseminated, distributed or used for any purpose without express written permission.

Do not use for final construction. Sign fabricator to verify and be responsible for all dimensions and work conditions and inform this office of variations prior to performing work. Written dimensions govern over scaled dimensions.

No.	Revisions

Date 15 May 2017

Project No. UCONN-046

Phase CID

Project Title
 University of Connecticut
 Campus Wayfinding

**Sign Type H2
 Secondary Pedestrian
 Directional**

CID.63

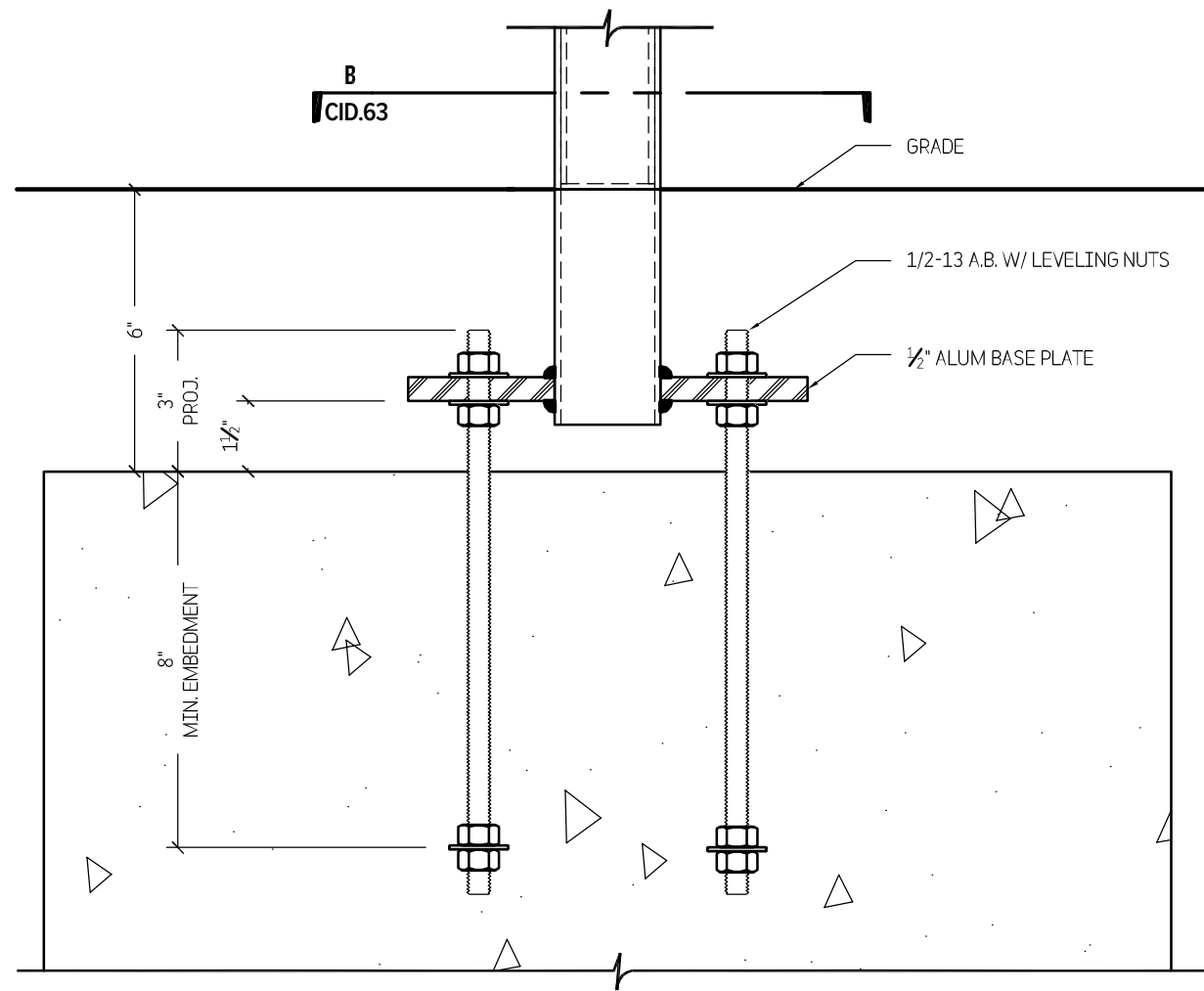

A SECTION
 3" = 1'-0"

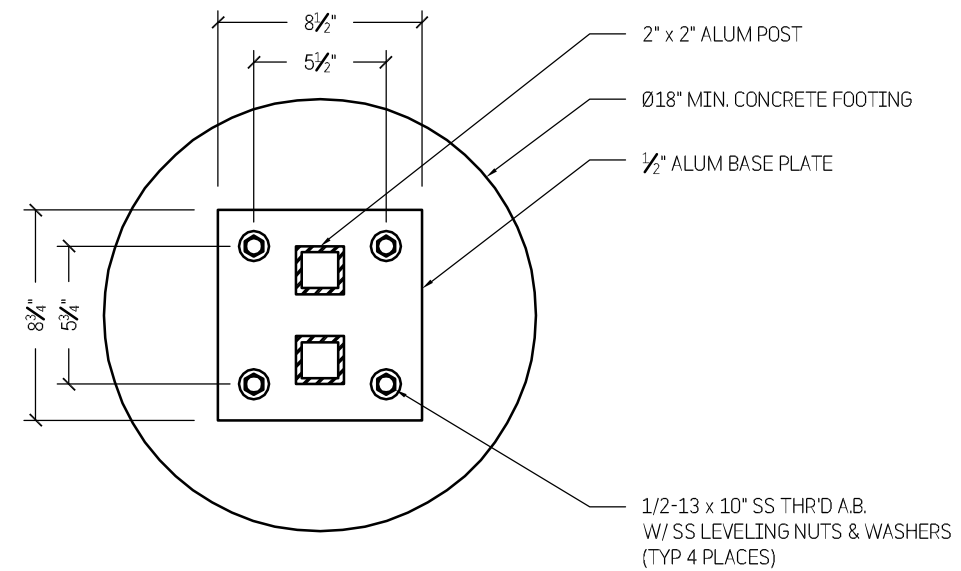

B SECTION
 1 1/2" = 1'-0"

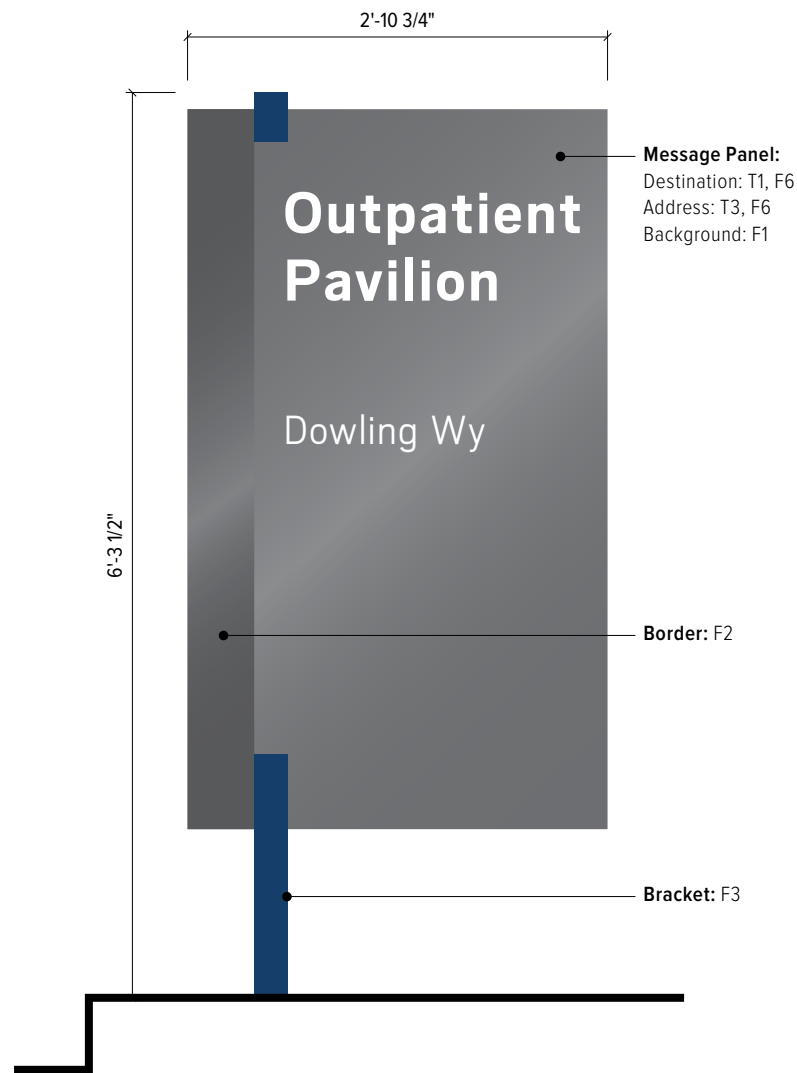

1 Elevation - Sign Type J0
3/4" = 1'-0"



2 Plan - Sign Type J0
3/4" = 1'-0"

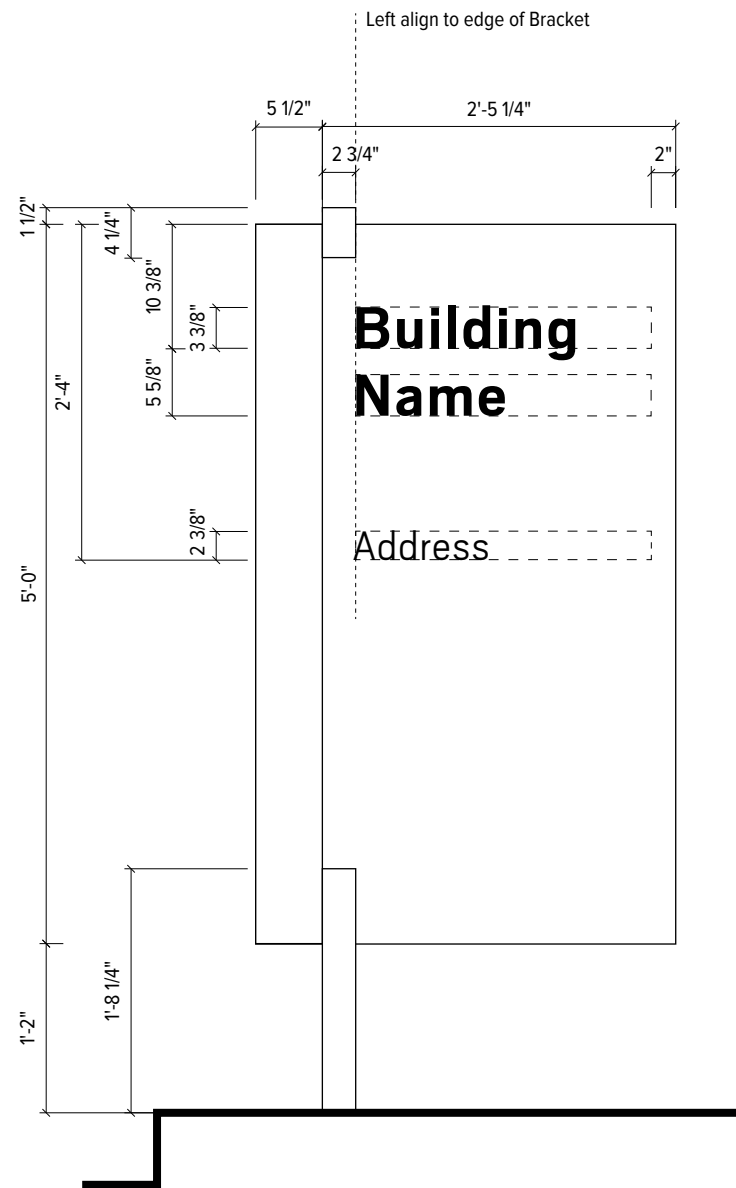

3 Graphic Layout - Sign Type J0
3/4" = 1'-0"

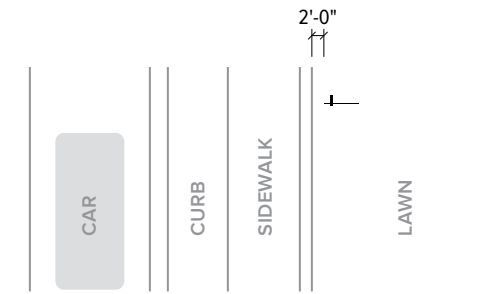

4 Installation Plan - Sign Type J0 (Typical)
NTS

NOTE: Sign orientation to be determined by University Representative

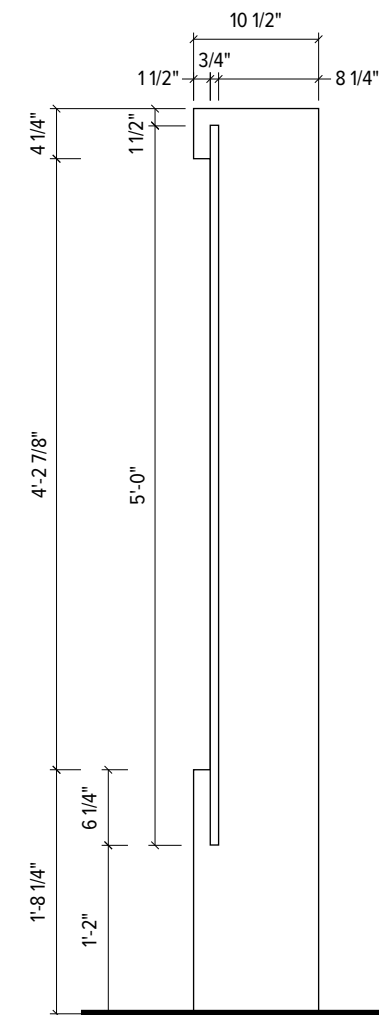

5 Side View - Sign Type J0
3/4" = 1'-0"

TWO TWELVE

902 BROADWAY
FLOOR 20
NEW YORK, NY
10010/6002
212 254/6670 T
212 254/6614 F

For Planning & Coordination Only –
Not for Construction

This document and the entirety of its contents are property of 212/Harakawa Inc. and/or Two Twelve Associates, Inc. No part of this document shall be duplicated, disseminated, distributed or used for any purpose without express written permission.

Do not use for final construction. Sign fabricator to verify and be responsible for all dimensions and work conditions and inform this office of variations prior to performing work. Written dimensions govern over scaled dimensions.

No.	Revisions

Date 15 May 2017

Project No. UCONN-046

Phase CID

Project Title
University of Connecticut
Campus Wayfinding

Sign Type J0
Primary Building ID,
Freestanding, Large

CID.64

Double-sided variation is permissible on a case-by-case basis upon request to the University's Representative.

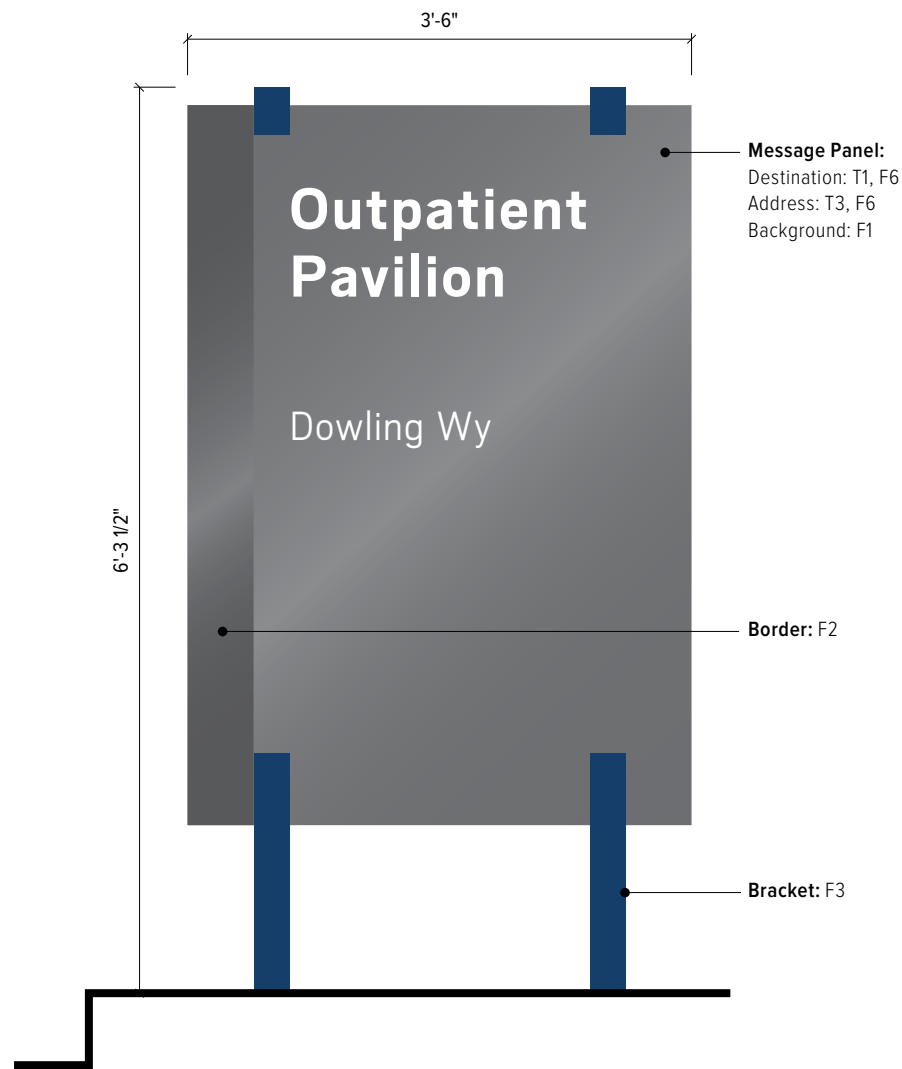

1 Elevation - Sign Type J0a
3/4" = 1'-0"



2 Plan - Sign Type J0a
3/4" = 1'-0"

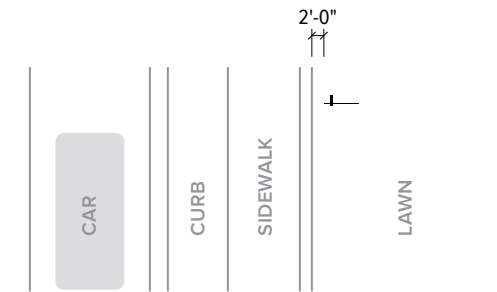

4 Installation Plan - Sign Type J0a (Typical)
NTS

NOTE: Sign orientation to be determined by University Representative

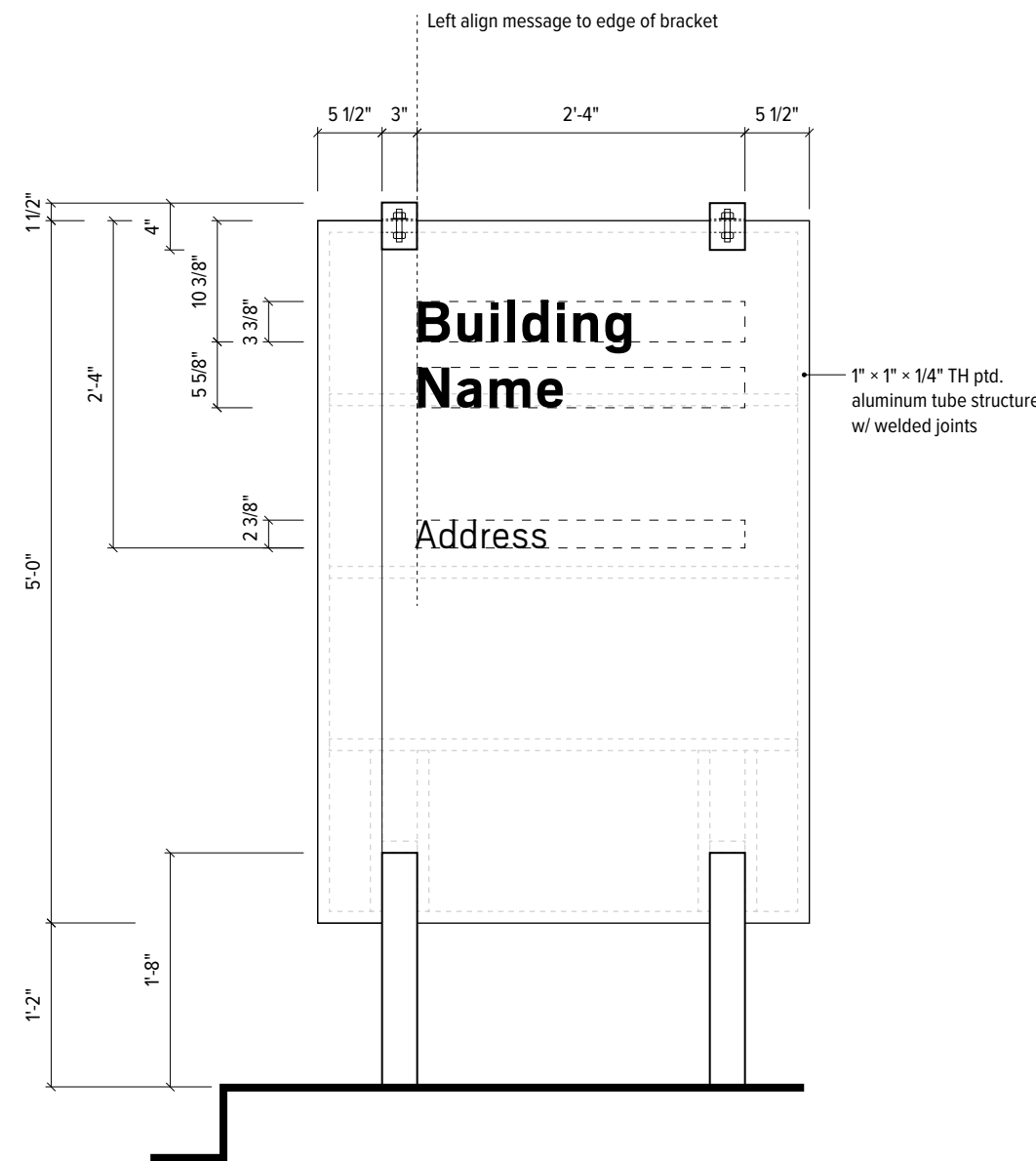

3 Graphic Layout - Sign Type J0a
3/4" = 1'-0"

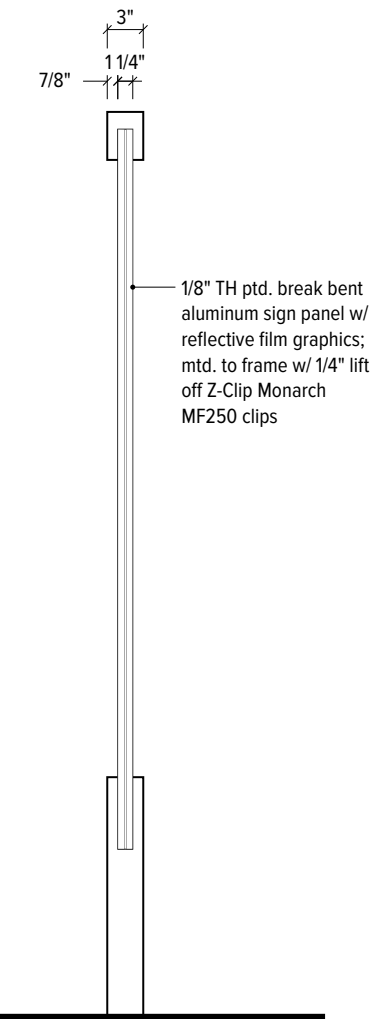

5 Side View - Sign Type J0a
3/4" = 1'-0"

TWO TWELVE

902 BROADWAY
FLOOR 20
NEW YORK, NY
10010/6002
212 254/6670 T
212 254/6614 F

For Planning & Coordination Only –
Not for Construction

This document and the entirety of its contents are property of 212/Harakawa Inc. and/or Two Twelve Associates, Inc. No part of this document shall be duplicated, disseminated, distributed or used for any purpose without express written permission.

Do not use for final construction. Sign fabricator to verify and be responsible for all dimensions and work conditions and inform this office of variations prior to performing work. Written dimensions govern over scaled dimensions.

No.	Revisions

Date 10 November 2017

Project No. UCONN-046

Phase CID

Project Title
University of Connecticut
Campus Wayfinding

Sign Type J0a
Primary Building ID,
Freestanding, Large Alt

CID.64A

TWO TWELVE

902 BROADWAY
 FLOOR 20
 NEW YORK, NY
 10010/6002
 212 254/6670 T
 212 254/6614 F

For Planning & Coordination Only –
 Not for Construction

This document and the entirety of its contents are property of 212/Harakawa Inc. and/or Two Twelve Associates, Inc. No part of this document shall be duplicated, disseminated, distributed or used for any purpose without express written permission.

Do not use for final construction. Sign fabricator to verify and be responsible for all dimensions and work conditions and inform this office of variations prior to performing work. Written dimensions govern over scaled dimensions.

No. Revisions

Date 15 May 2017

Project No. UCONN-046

Phase CID

Project Title
 University of Connecticut
 Campus Wayfinding

Sign Type J0
Primary Building ID,
Freestanding, Large

CID.65

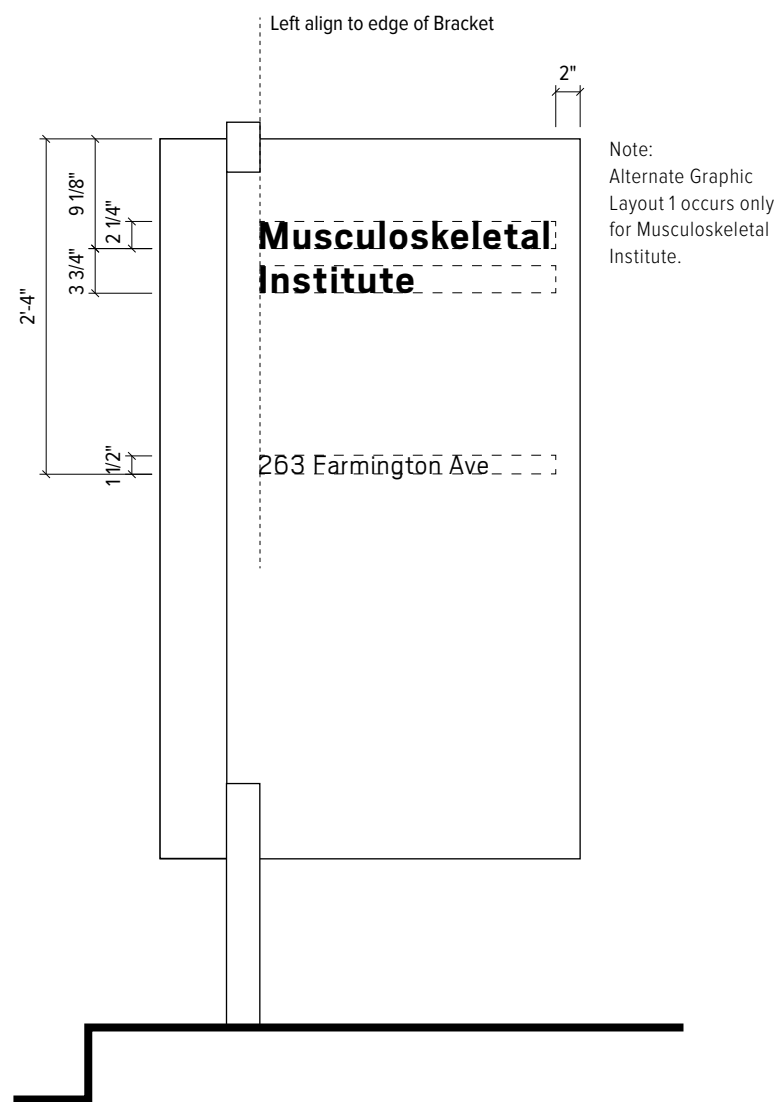

1 Alternate Graphic Layout 1 - Sign Type J0
 3/4" = 1'-0"

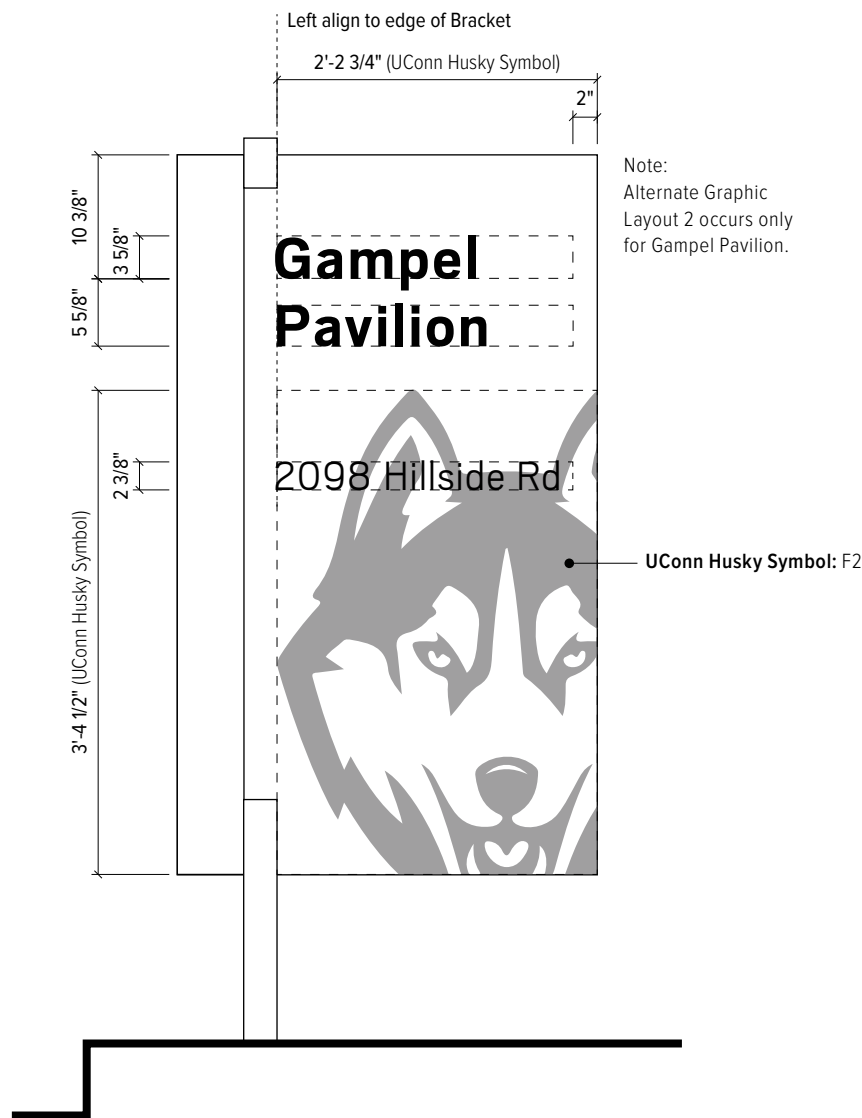

2 Alternate Graphic Layout 2 - Sign Type J0
 3/4" = 1'-0"

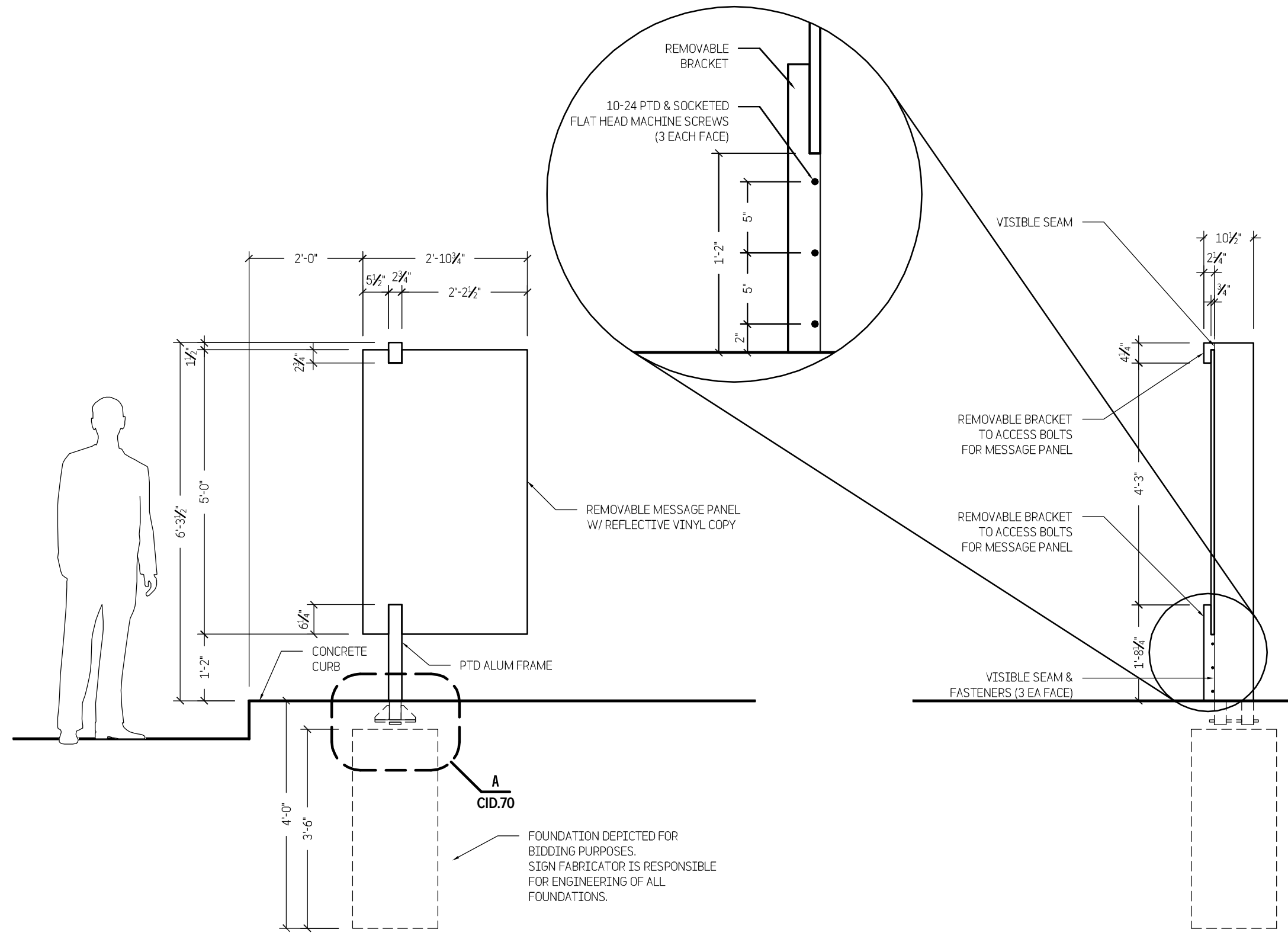

1 ELEVATION
1/2" = 1'-0"

2 SIDE VIEW
1/2" = 1'-0"

TWO TWELVE

902 BROADWAY
FLOOR 20
NEW YORK, NY
10010/6002
212 254/6670 T
212 254/6614 F

For Planning & Coordination Only –
Not for Construction

This document and the entirety of its contents are property of 212/Harakawa Inc. and/or Two Twelve Associates, Inc. No part of this document shall be duplicated, disseminated, distributed or used for any purpose without express written permission.

Do not use for final construction. Sign fabricator to verify and be responsible for all dimensions and work conditions and inform this office of variations prior to performing work. Written dimensions govern over scaled dimensions.

No.	Revisions

Date 15 May 2017

Project No. UCONN-046

Phase CID

Project Title
University of Connecticut
Campus Wayfinding

Sign Type J0
Primary Building ID,
Freestanding, Large

CID.66

TWO TWELVE

902 BROADWAY
FLOOR 20
NEW YORK, NY
10010/6002
212 254/6670 T
212 254/6614 F

For Planning & Coordination Only –
Not for Construction

This document and the entirety of its
contents are property of 212/Harakawa
Inc. and/or Two Twelve Associates, Inc.
No part of this document shall be
duplicated, disseminated, distributed
or used for any purpose without
express written permission.

Do not use for final construction. Sign
fabricator to verify and be responsible
for all dimensions and work conditions
and inform this office of variations prior
to performing work. Written dimensions
govern over scaled dimensions.

No.	Revisions

Date 15 May 2017

Project No. UCONN-046

Phase CID

Project Title
University of Connecticut
Campus Wayfinding

Sign Type J0
Primary Building ID,
Freestanding, Large

CID.67

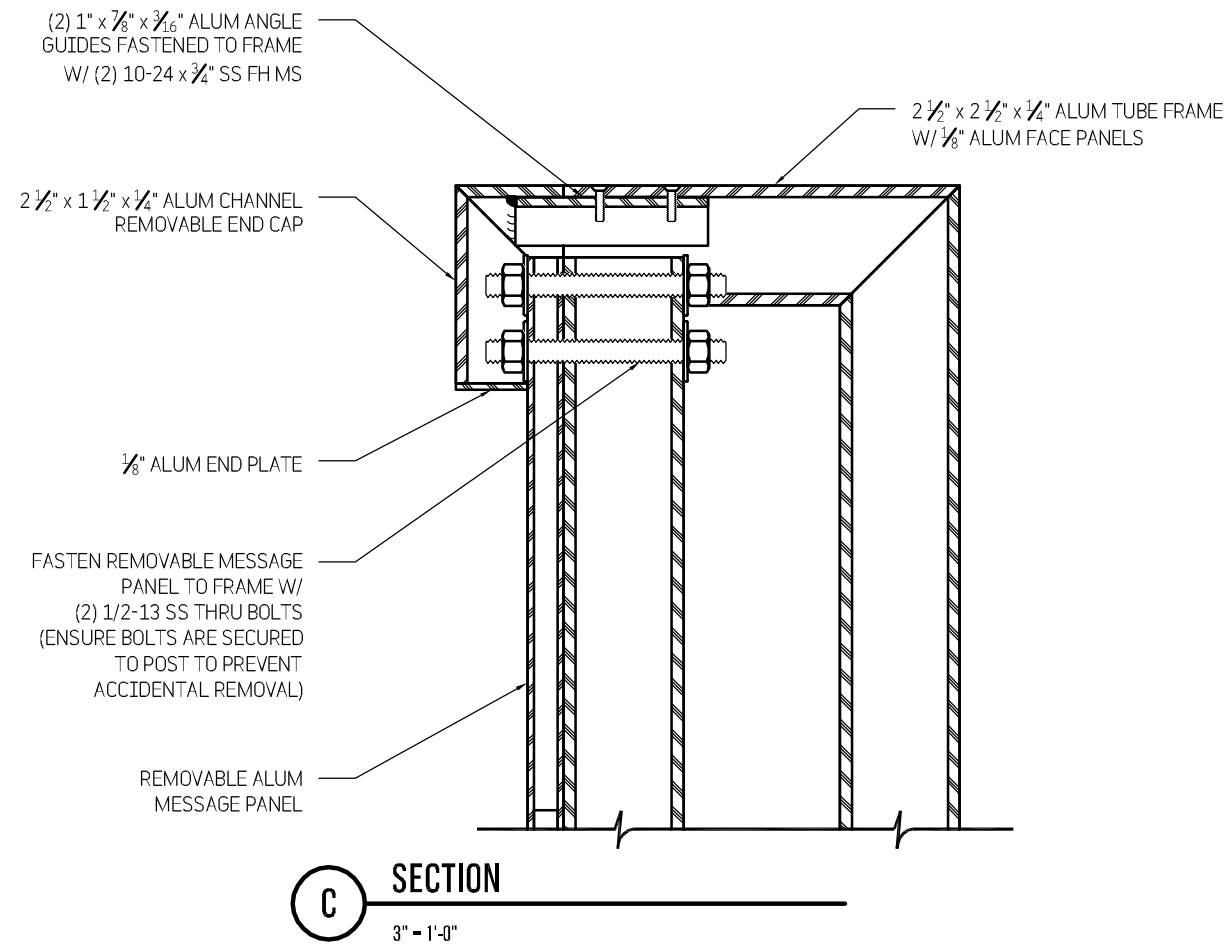
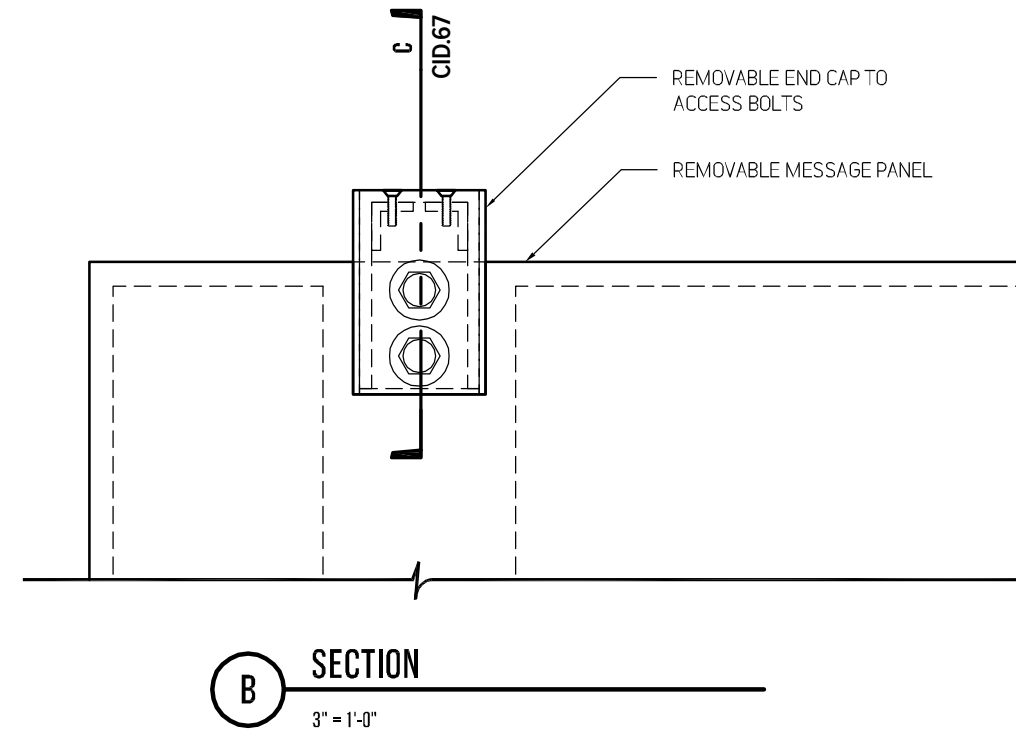
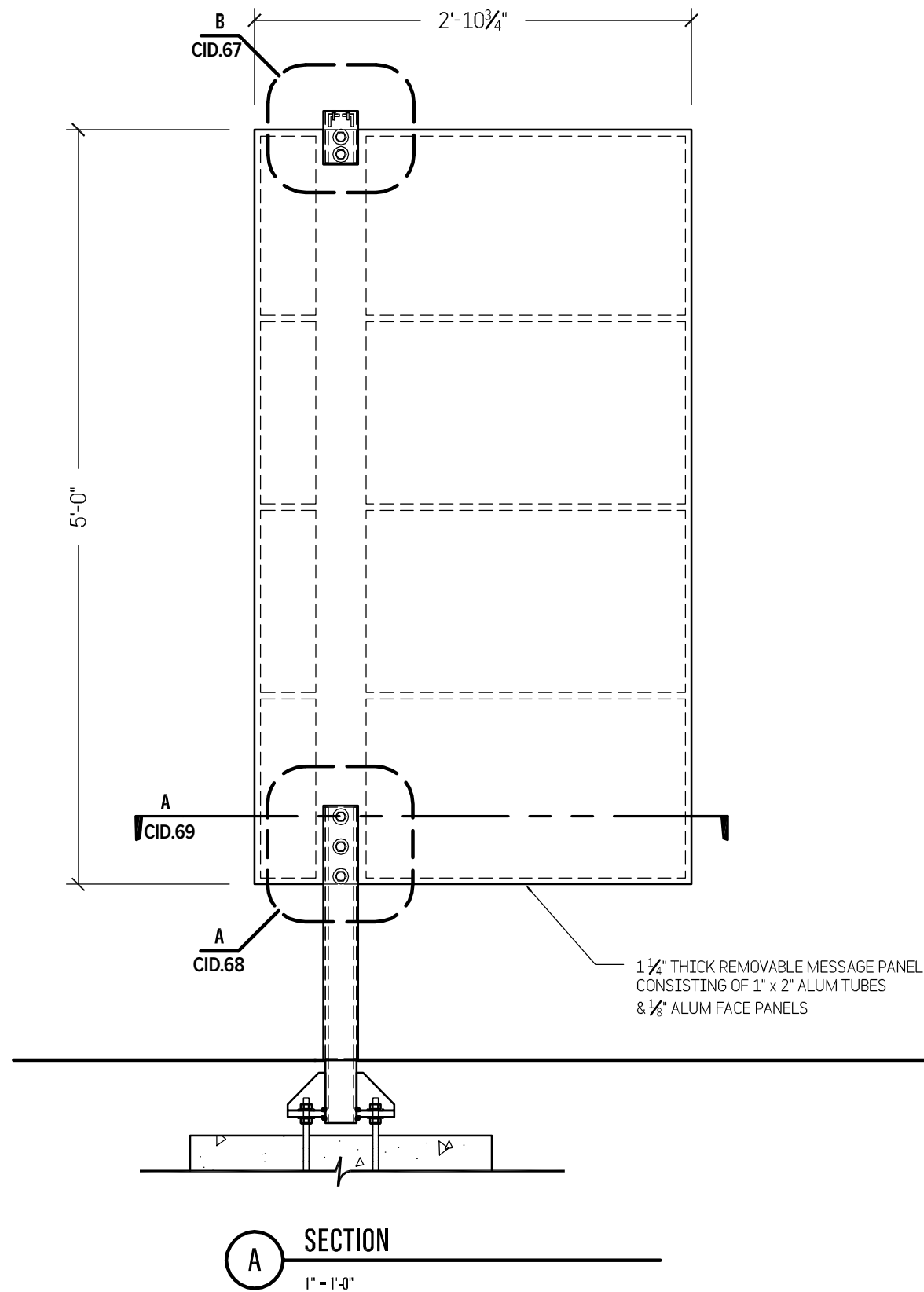

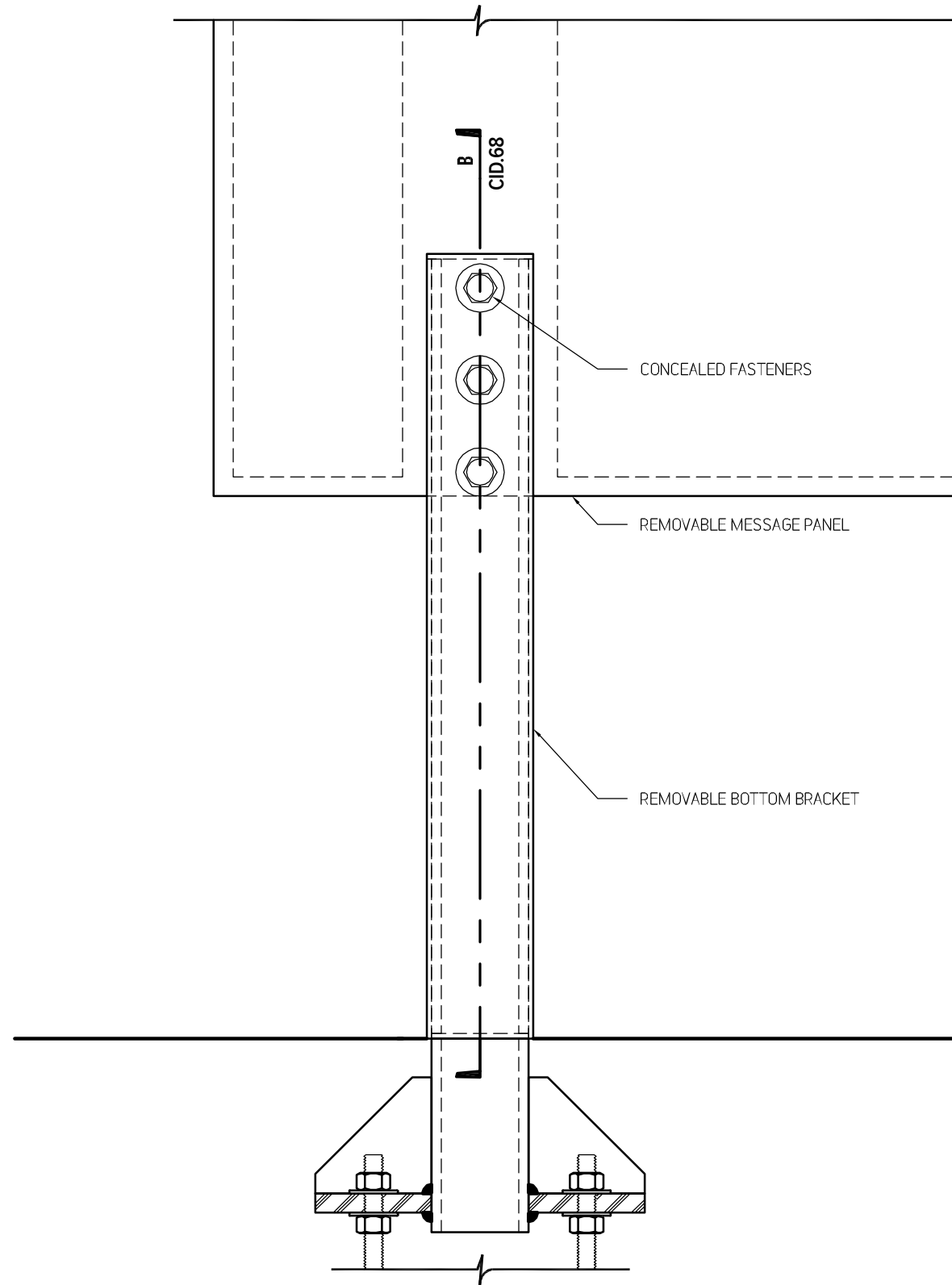

A SECTION
3" = 1'-0"

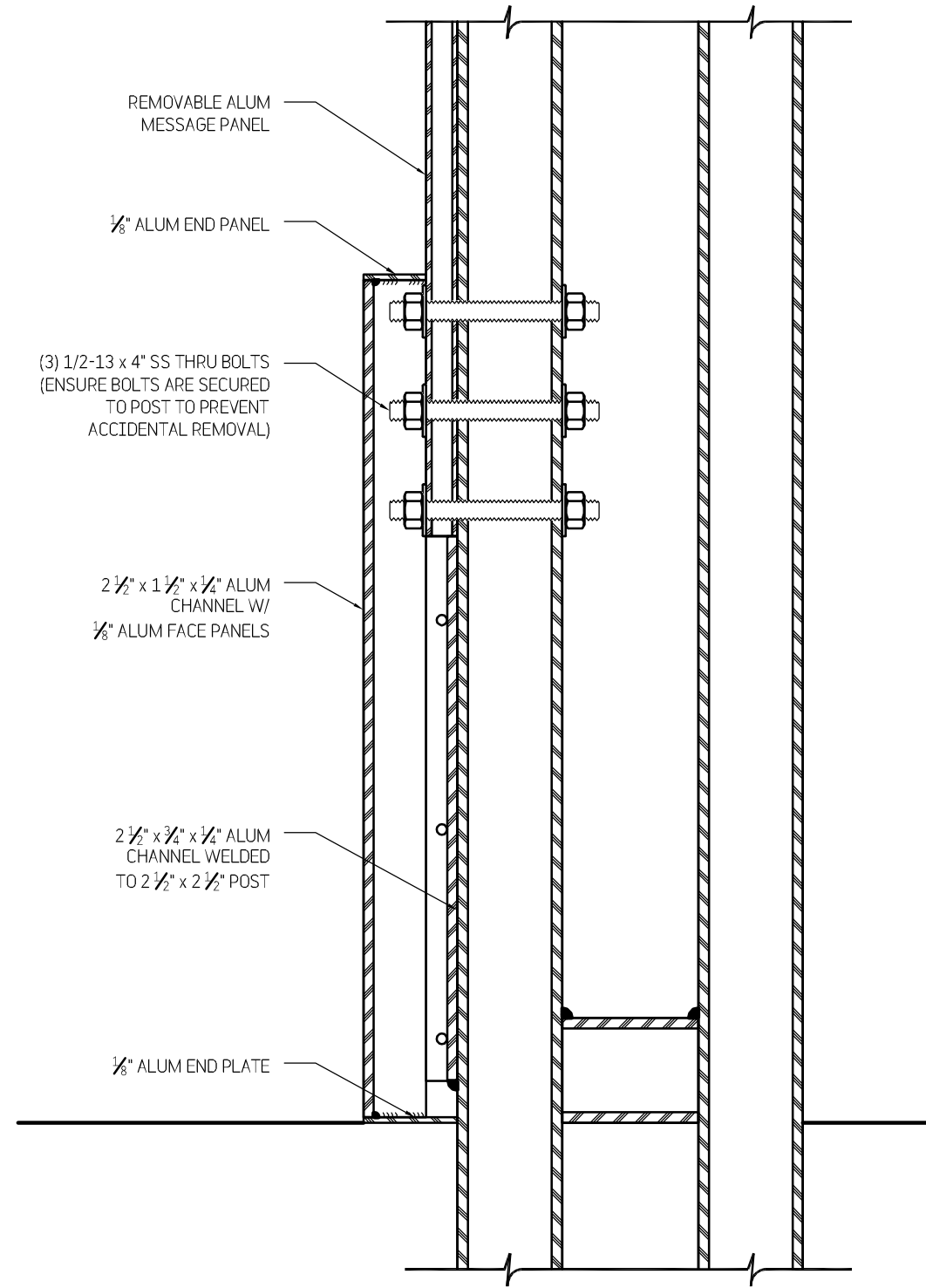

B SECTION
3" = 1'-0"

TWO TWELVE

902 BROADWAY
FLOOR 20
NEW YORK, NY
10010/6002
212 254/6670 T
212 254/6614 F

For Planning & Coordination Only –
Not for Construction

This document and the entirety of its contents are property of 212/Harakawa Inc. and/or Two Twelve Associates, Inc. No part of this document shall be duplicated, disseminated, distributed or used for any purpose without express written permission.

Do not use for final construction. Sign fabricator to verify and be responsible for all dimensions and work conditions and inform this office of variations prior to performing work. Written dimensions govern over scaled dimensions.

No.	Revisions

Date 15 May 2017

Project No. UCONN-046

Phase CID

Project Title
University of Connecticut
Campus Wayfinding

Sign Type J0
Primary Building ID,
Freestanding, Large

CID.68

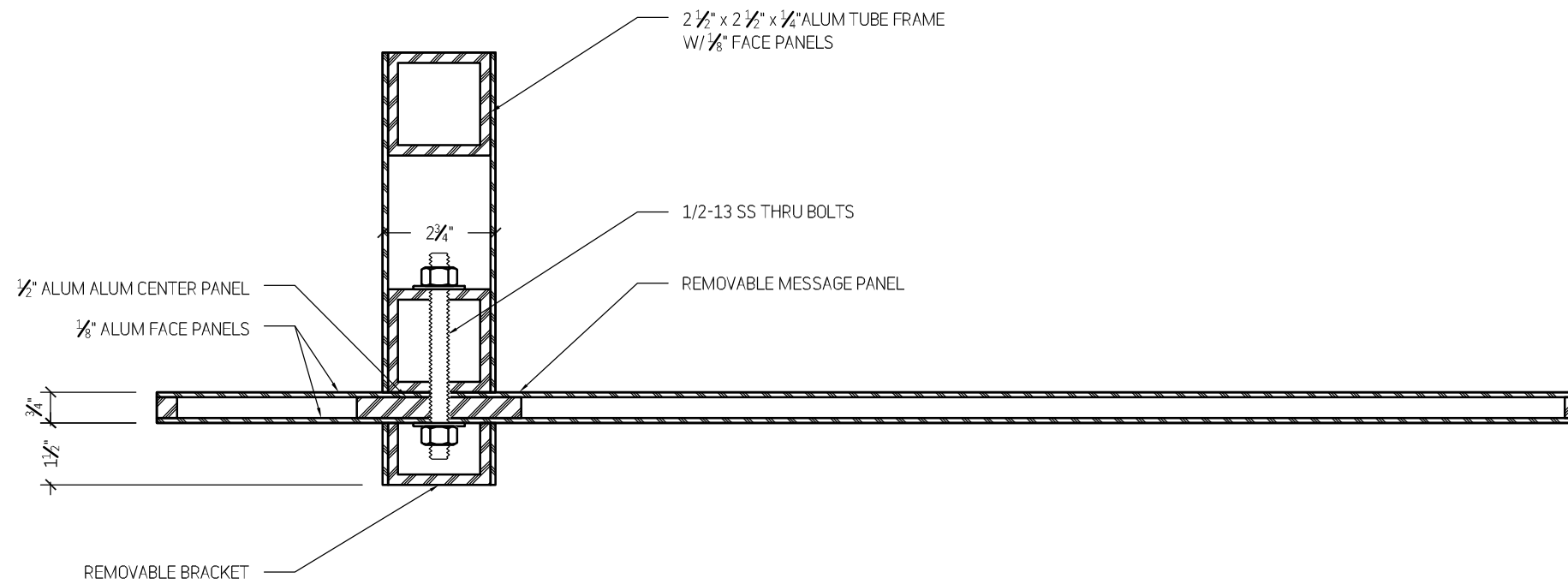

A SECTION
3" - 1'-0"

TWO TWELVE

902 BROADWAY
FLOOR 20
NEW YORK, NY
10010/6002
212 254/6670 T
212 254/6614 F

For Planning & Coordination Only –
Not for Construction

This document and the entirety of its contents are property of 212/Harakawa Inc. and/or Two Twelve Associates, Inc. No part of this document shall be duplicated, disseminated, distributed or used for any purpose without express written permission.

Do not use for final construction. Sign fabricator to verify and be responsible for all dimensions and work conditions and inform this office of variations prior to performing work. Written dimensions govern over scaled dimensions.

No.	Revisions

Date 15 May 2017

Project No. UCONN-046

Phase CID

Project Title
University of Connecticut
Campus Wayfinding

Sign Type J0
Primary Building ID,
Freestanding, Large

CID.69

TWO TWELVE

902 BROADWAY
 FLOOR 20
 NEW YORK, NY
 10010/6002
 212 254/6670 T
 212 254/6614 F

For Planning & Coordination Only –
 Not for Construction

This document and the entirety of its contents are property of 212/Harakawa Inc. and/or Two Twelve Associates, Inc. No part of this document shall be duplicated, disseminated, distributed or used for any purpose without express written permission.

Do not use for final construction. Sign fabricator to verify and be responsible for all dimensions and work conditions and inform this office of variations prior to performing work. Written dimensions govern over scaled dimensions.

No.	Revisions

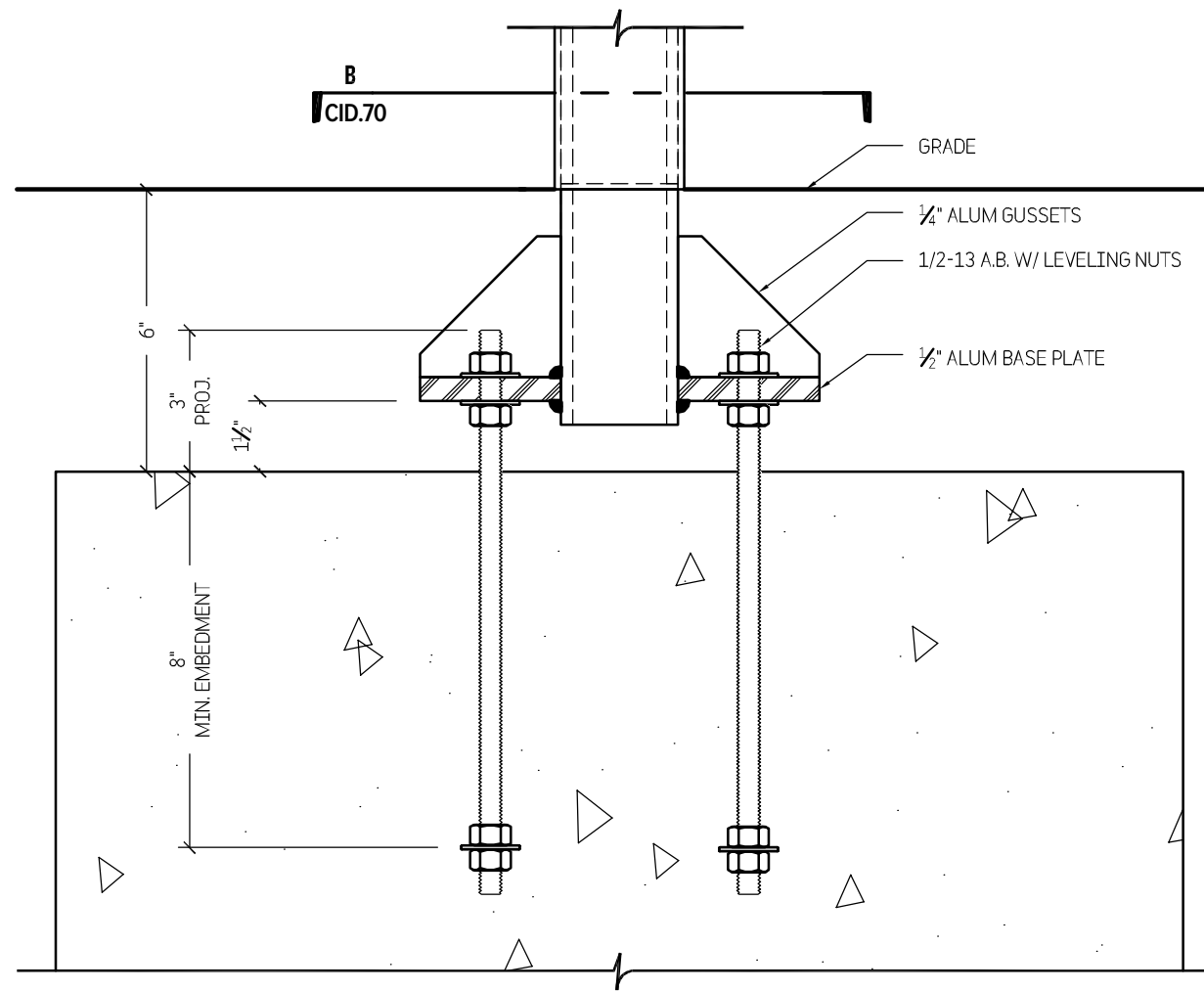

A SECTION
 3" = 1'-0"

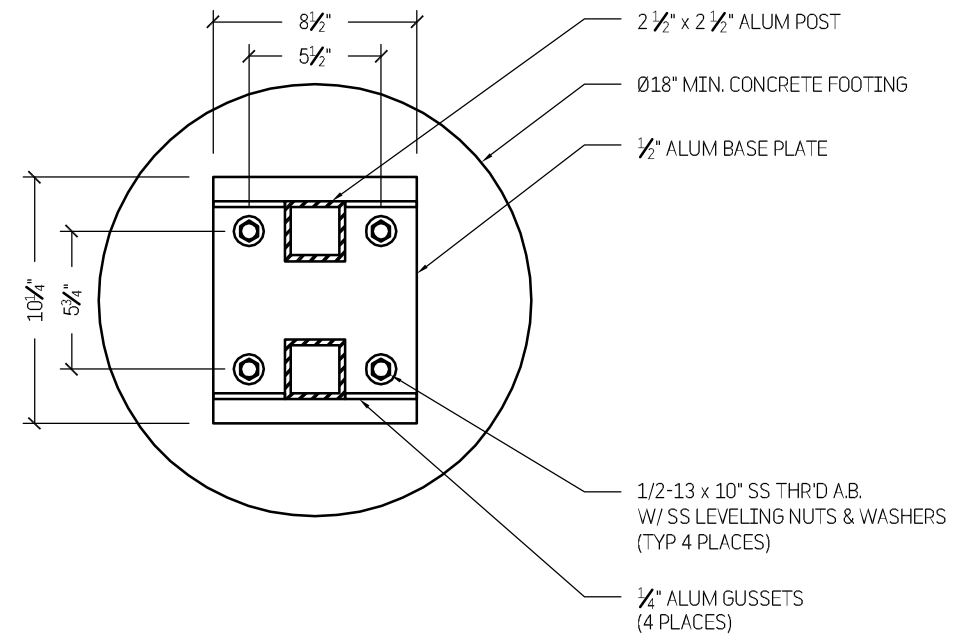

B SECTION
 1 1/2" = 1'-0"

Date 15 May 2017

Project No. UCONN-046

Phase CID

Project Title
 University of Connecticut
 Campus Wayfinding

Sign Type J0
 Primary Building ID,
 Freestanding, Large

CID.70

Double-sided variation is permissible on a case-by-case basis upon request to the University's Representative.

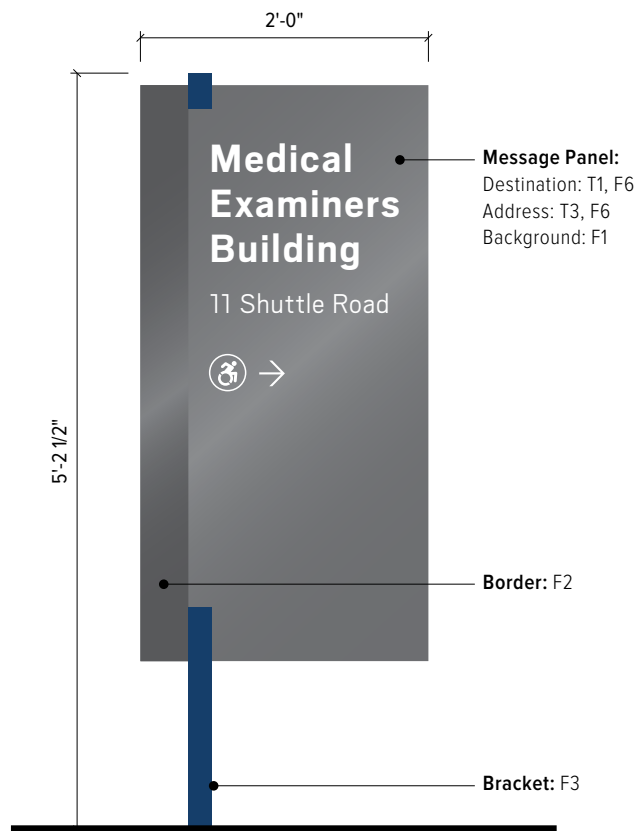

1 Elevation - Sign Type J1
3/4" = 1'-0"



2 Plan - Sign Type J1
3/4" = 1'-0"

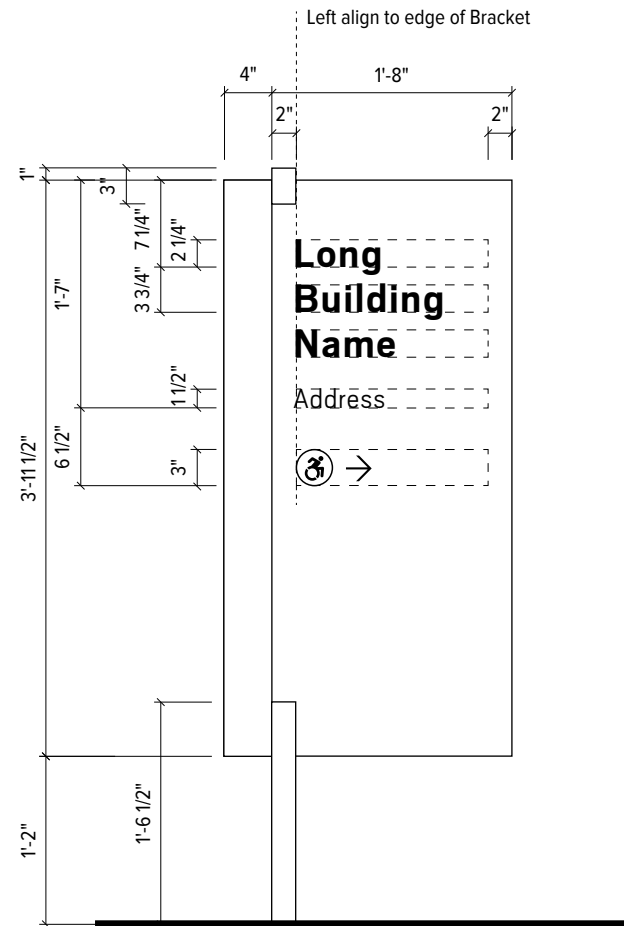

3 Graphic Layout - Sign Type J1
3/4" = 1'-0"

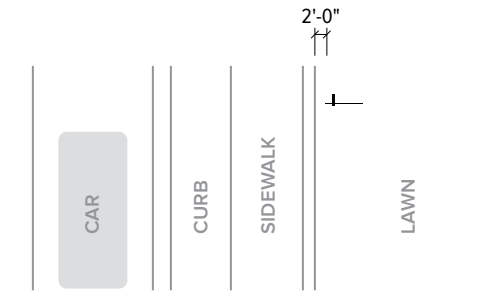

4 Installation Plan - Sign Type J1 (Typical)
NTS

NOTE: Sign orientation to be determined by University Representative

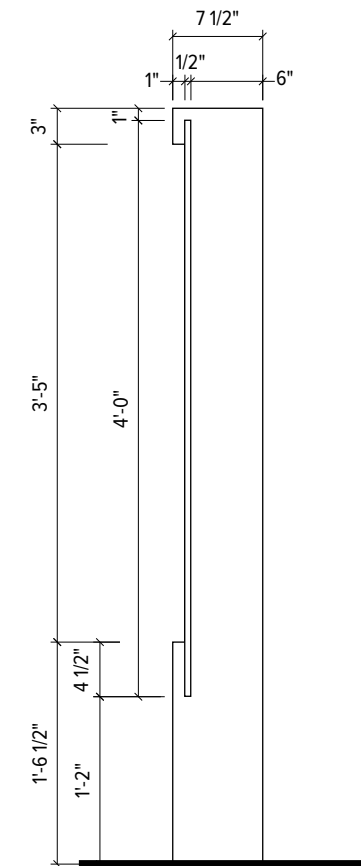

4 Side View - Sign Type J1
3/4" = 1'-0"

TWO TWELVE

902 BROADWAY
FLOOR 20
NEW YORK, NY
10010/6002
212 254/6670 T
212 254/6614 F

For Planning & Coordination Only –
Not for Construction

This document and the entirety of its contents are property of 212/Harakawa Inc. and/or Two Twelve Associates, Inc. No part of this document shall be duplicated, disseminated, distributed or used for any purpose without express written permission.

Do not use for final construction. Sign fabricator to verify and be responsible for all dimensions and work conditions and inform this office of variations prior to performing work. Written dimensions govern over scaled dimensions.

No.	Revisions

Date 15 May 2017

Project No. UCONN-046

Phase CID

Project Title
University of Connecticut
Campus Wayfinding

Sign Type J1
Primary Building ID,
Freestanding, Small

CID.71

TWO TWELVE

902 BROADWAY
 FLOOR 20
 NEW YORK, NY
 10010/6002
 212 254/6670 T
 212 254/6614 F

For Planning & Coordination Only –
 Not for Construction

This document and the entirety of its contents are property of 212/Harakawa Inc. and/or Two Twelve Associates, Inc. No part of this document shall be duplicated, disseminated, distributed or used for any purpose without express written permission.

Do not use for final construction. Sign fabricator to verify and be responsible for all dimensions and work conditions and inform this office of variations prior to performing work. Written dimensions govern over scaled dimensions.

No.	Revisions

Date 15 May 2017

Project No. UCONN-046

Phase CID

Project Title
 University of Connecticut
 Campus Wayfinding

Sign Type J1
 Primary Building ID,
 Freestanding, Small

CID.72

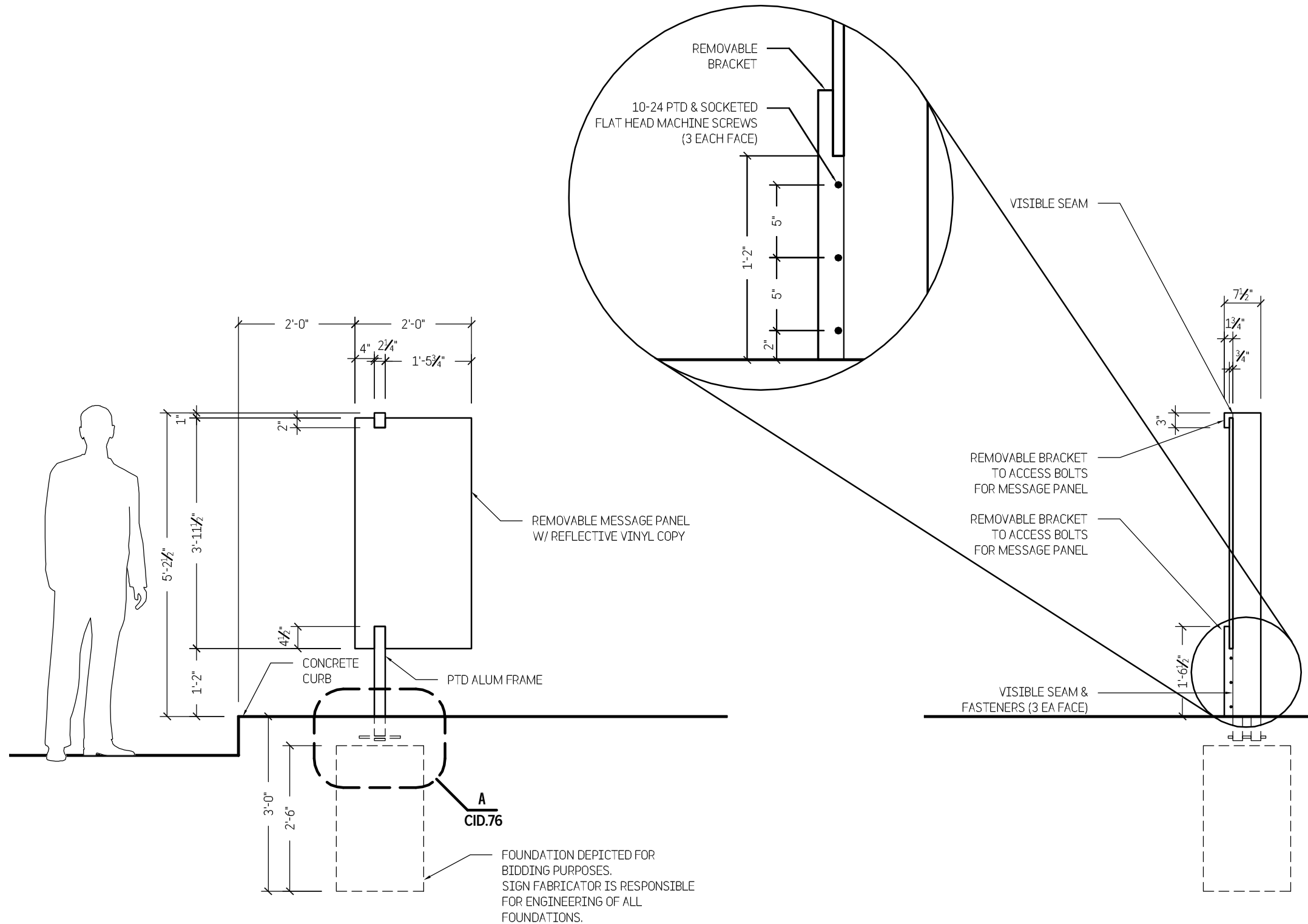

1 ELEVATION
 1/2" = 1'-0"

2 SIDE VIEW
 1/2" = 1'-0"

TWO TWELVE

902 BROADWAY
 FLOOR 20
 NEW YORK, NY
 10010/6002
 212 254/6670 T
 212 254/6614 F

For Planning & Coordination Only –
 Not for Construction

This document and the entirety of its
 contents are property of 212/Harakawa
 Inc. and/or Two Twelve Associates, Inc.
 No part of this document shall be
 duplicated, disseminated, distributed
 or used for any purpose without
 express written permission.

Do not use for final construction. Sign
 fabricator to verify and be responsible
 for all dimensions and work conditions
 and inform this office of variations prior
 to performing work. Written dimensions
 govern over scaled dimensions.

No.	Revisions

Date 15 May 2017

Project No. UCONN-046

Phase CID

Project Title
 University of Connecticut
 Campus Wayfinding

Sign Type J1
 Primary Building ID,
 Freestanding, Small

CID.73

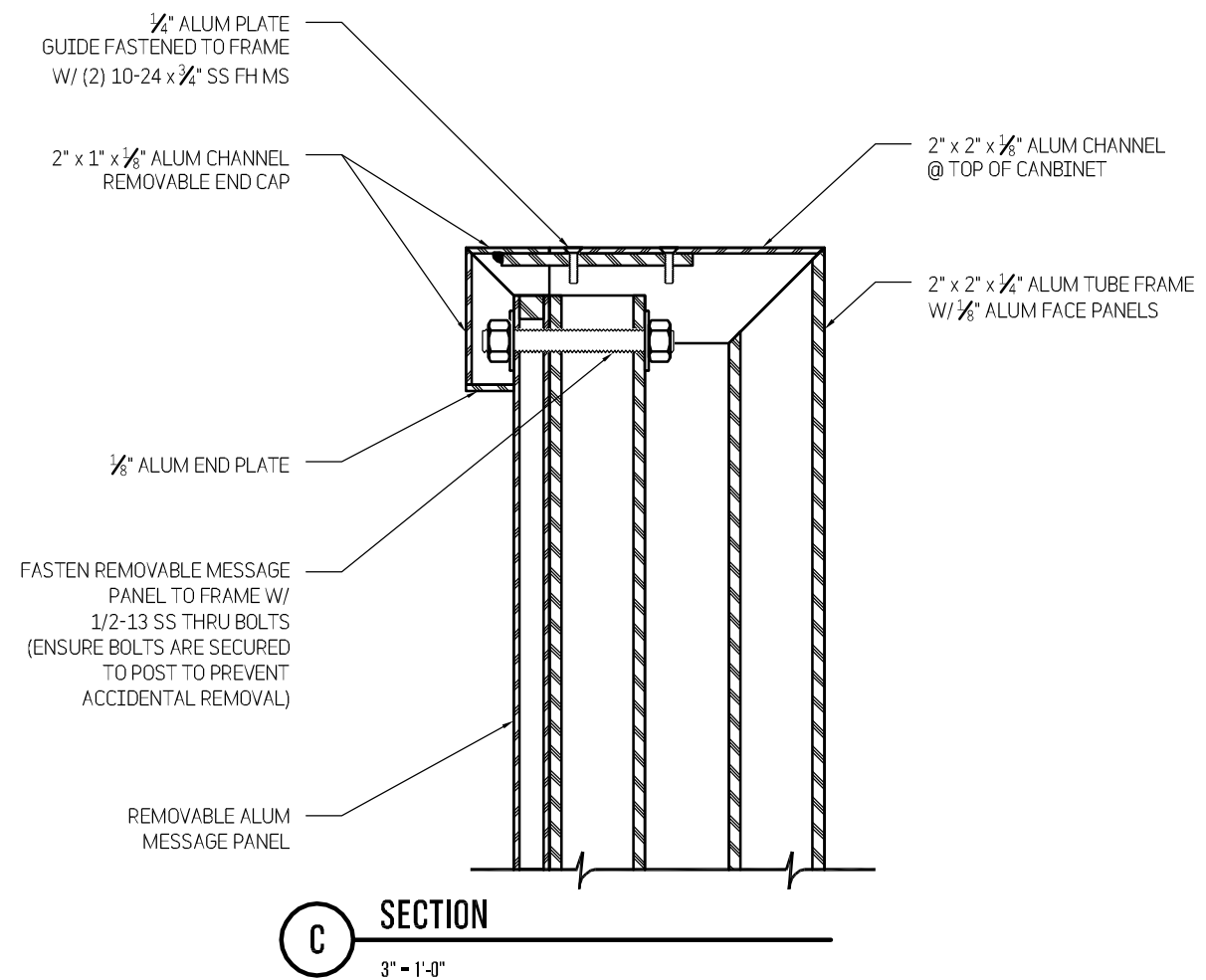
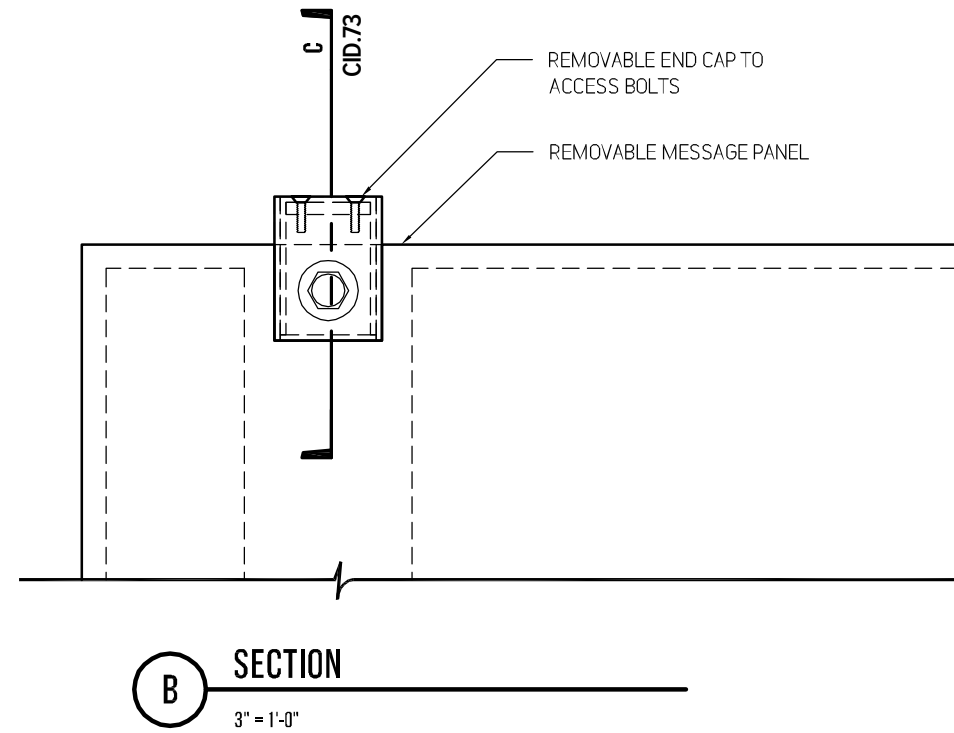
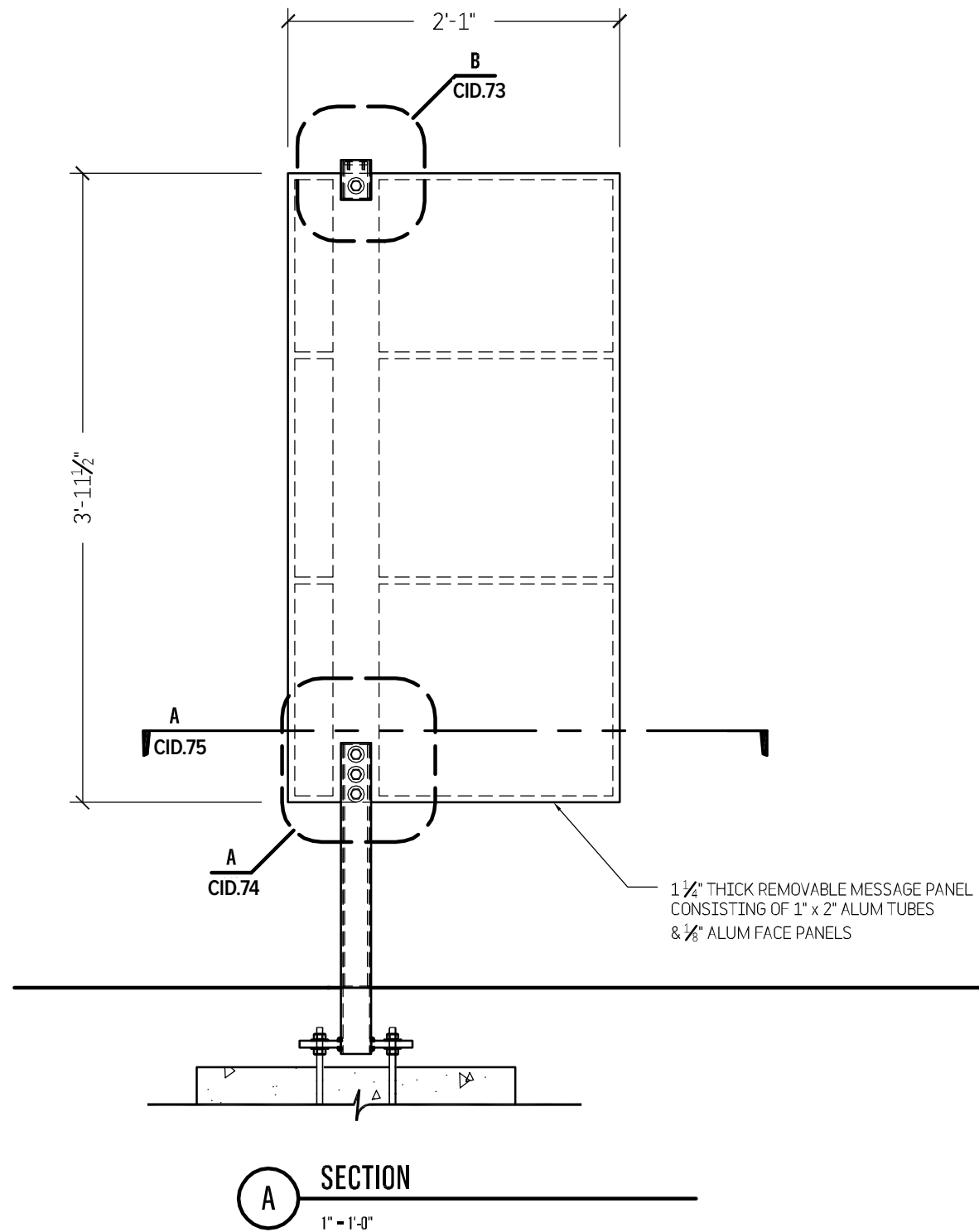

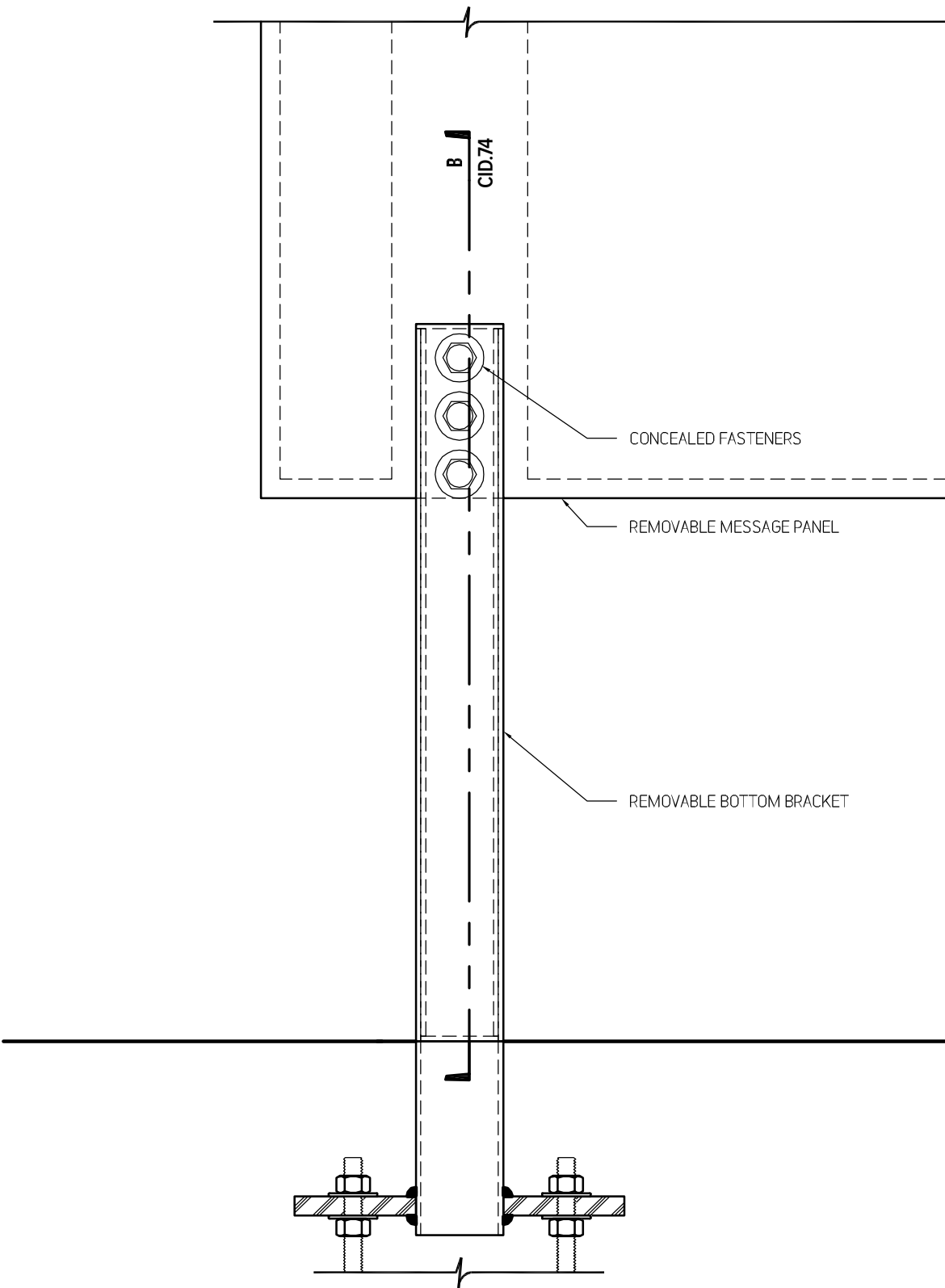

A SECTION
3" = 1'-0"

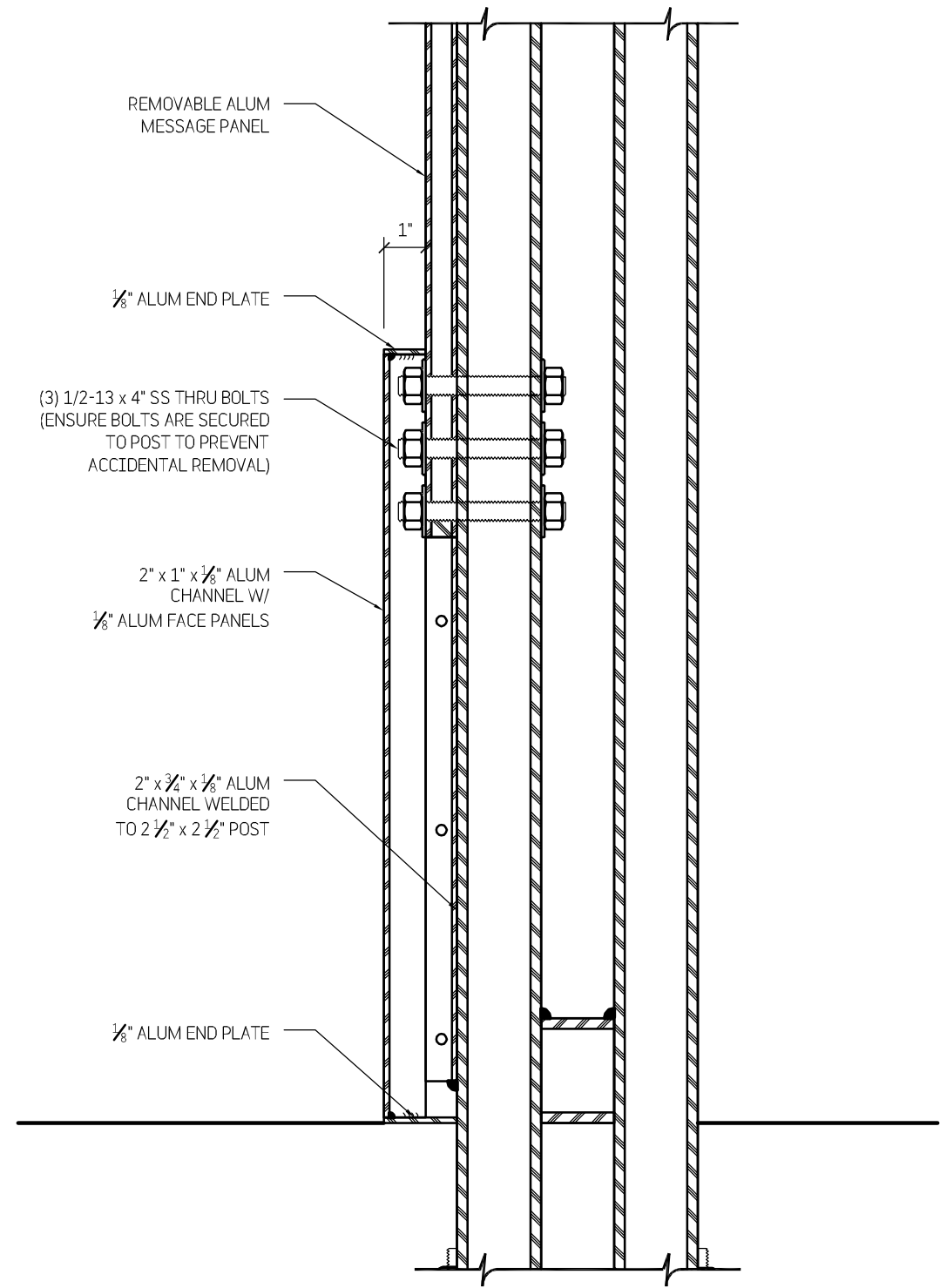

B SECTION
3" = 1'-0"

TWO TWELVE

902 BROADWAY
FLOOR 20
NEW YORK, NY
10010/6002
212 254/6670 T
212 254/6614 F

For Planning & Coordination Only –
Not for Construction

This document and the entirety of its
contents are property of 212/Harakawa
Inc. and/or Two Twelve Associates, Inc.
No part of this document shall be
duplicated, disseminated, distributed
or used for any purpose without
express written permission.

Do not use for final construction. Sign
fabricator to verify and be responsible
for all dimensions and work conditions
and inform this office of variations prior
to performing work. Written dimensions
govern over scaled dimensions.

No.	Revisions

Date 15 May 2017

Project No. UCONN-046

Phase CID

Project Title
University of Connecticut
Campus Wayfinding

Sign Type J1
Primary Building ID,
Freestanding, Small

CID.74

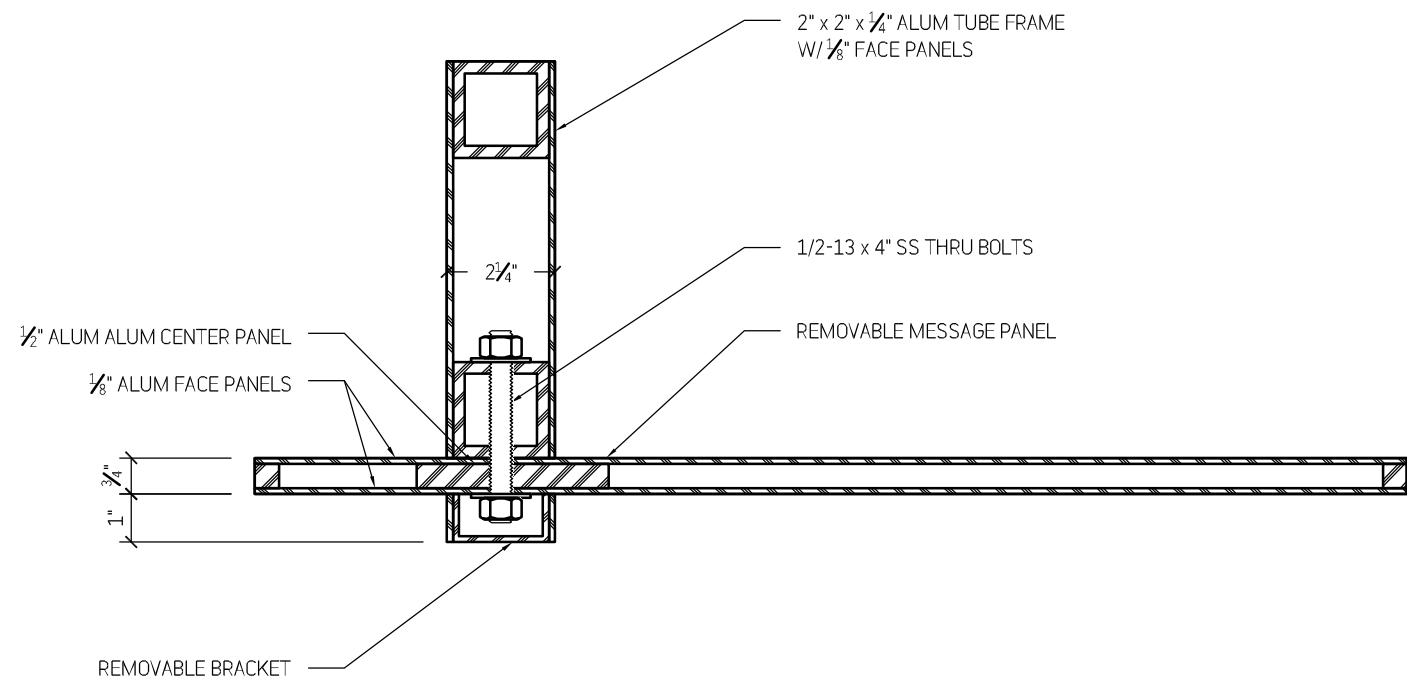

A SECTION
3" - 1'-0"

TWO TWELVE

902 BROADWAY
FLOOR 20
NEW YORK, NY
10010/6002
212 254/6670 T
212 254/6614 F

For Planning & Coordination Only –
Not for Construction

This document and the entirety of its contents are property of 212/Harakawa Inc. and/or Two Twelve Associates, Inc. No part of this document shall be duplicated, disseminated, distributed or used for any purpose without express written permission.

Do not use for final construction. Sign fabricator to verify and be responsible for all dimensions and work conditions and inform this office of variations prior to performing work. Written dimensions govern over scaled dimensions.

No.	Revisions

Date 15 May 2017

Project No. UCONN-046

Phase CID

Project Title

University of Connecticut
Campus Wayfinding

Sign Type J1
Primary Building ID,
Freestanding, Small

CID.75

TWO TWELVE

902 BROADWAY
 FLOOR 20
 NEW YORK, NY
 10010/6002
 212 254/6670 T
 212 254/6614 F

For Planning & Coordination Only –
 Not for Construction

This document and the entirety of its
 contents are property of 212/Harakawa
 Inc. and/or Two Twelve Associates, Inc.
 No part of this document shall be
 duplicated, disseminated, distributed
 or used for any purpose without
 express written permission.

Do not use for final construction. Sign
 fabricator to verify and be responsible
 for all dimensions and work conditions
 and inform this office of variations prior
 to performing work. Written dimensions
 govern over scaled dimensions.

No.	Revisions

Date 15 May 2017

Project No. UCONN-046

Phase CID

Project Title
 University of Connecticut
 Campus Wayfinding

Sign Type J1
Primary Building ID,
Freestanding, Small

CID.76

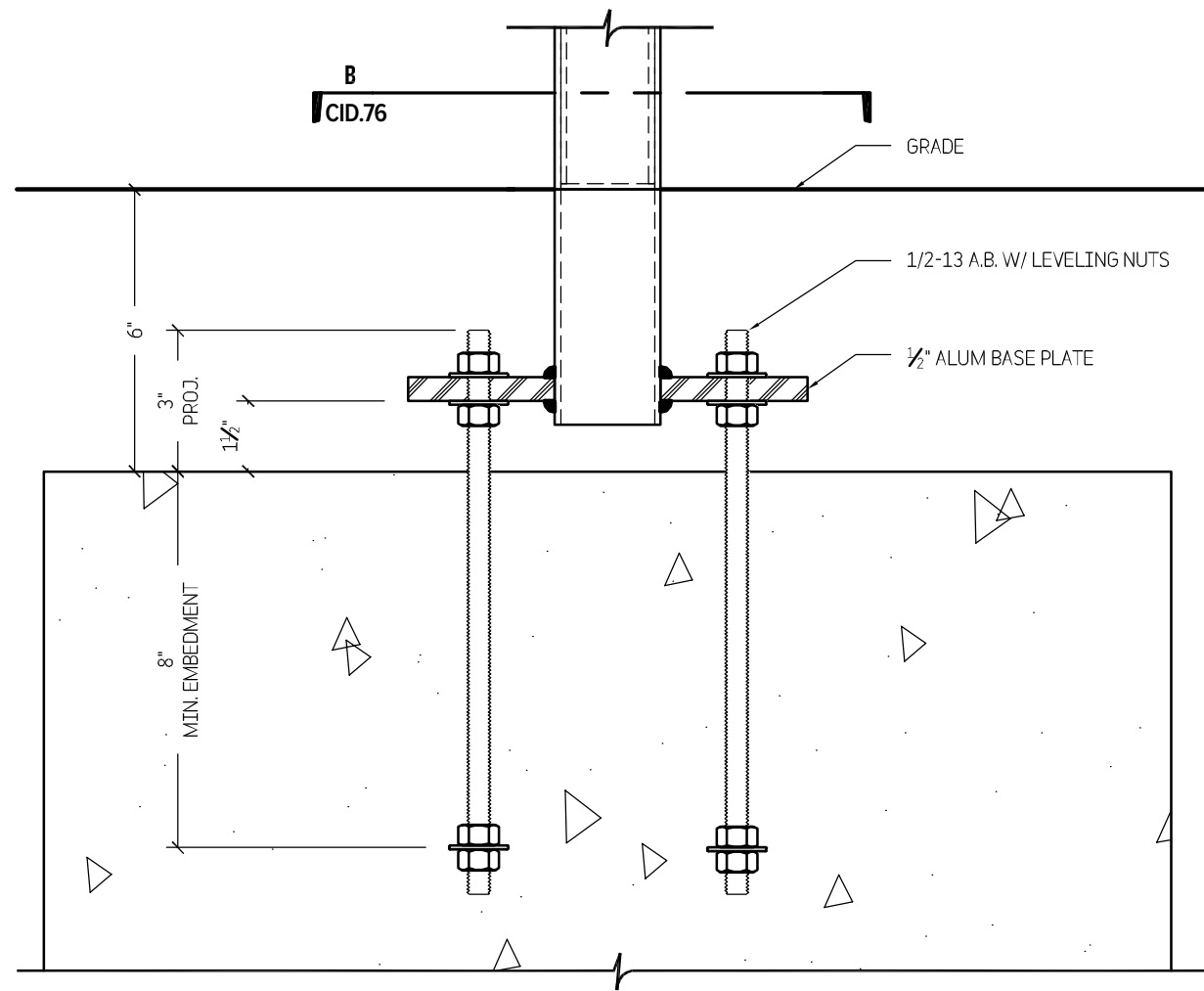

A SECTION
 3" = 1'-0"

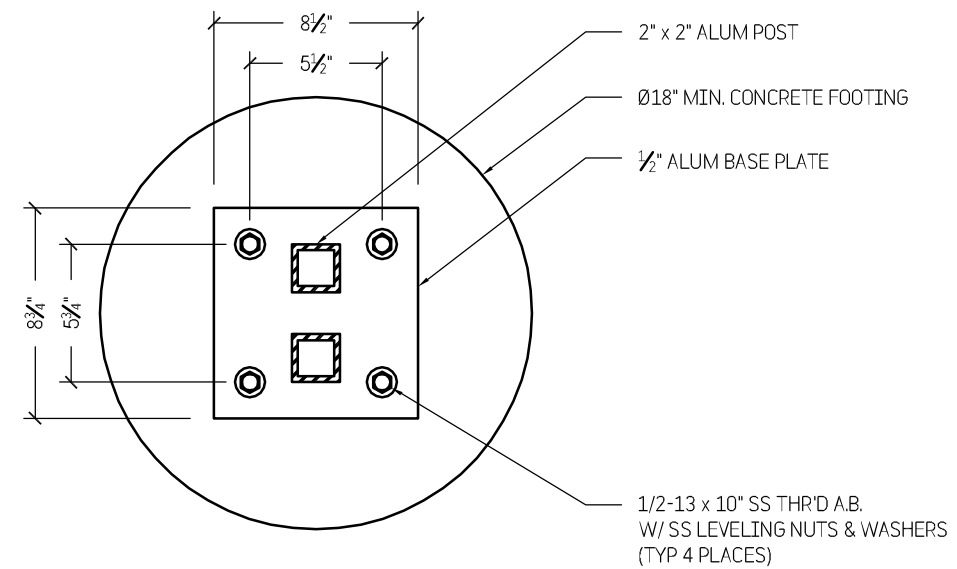

B SECTION
 1 1/2" = 1'-0"

Double-sided variation is permissible on a case-by-case basis upon request to the University's Representative.

TWO TWELVE

902 BROADWAY
FLOOR 20
NEW YORK, NY
10010/6002
212 254/6670 T
212 254/6614 F

For Planning & Coordination Only –
Not for Construction

This document and the entirety of its contents are property of 212/Harakawa Inc. and/or Two Twelve Associates, Inc. No part of this document shall be duplicated, disseminated, distributed or used for any purpose without express written permission.

Do not use for final construction. Sign fabricator to verify and be responsible for all dimensions and work conditions and inform this office of variations prior to performing work. Written dimensions govern over scaled dimensions.

No.	Revisions

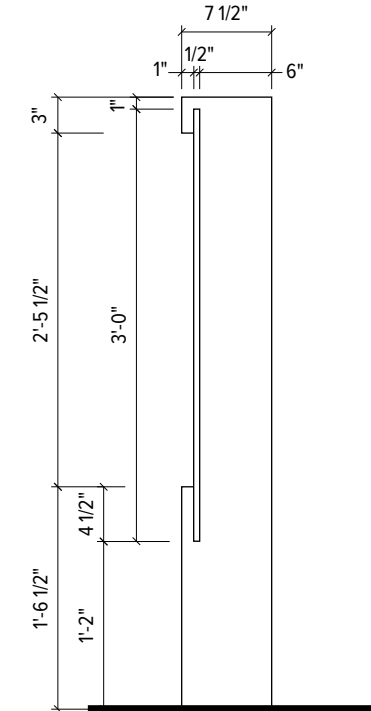
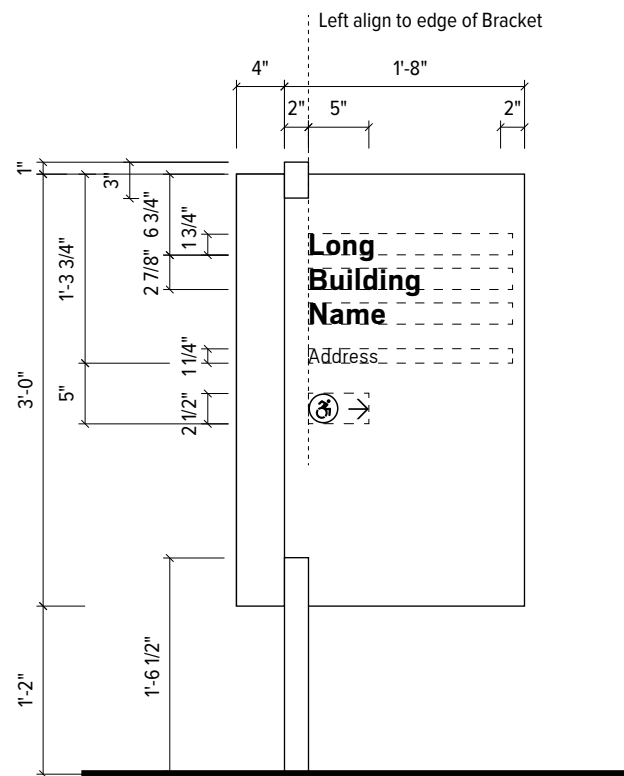
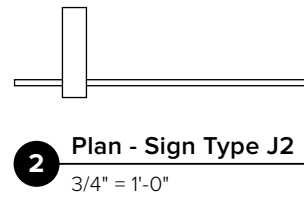
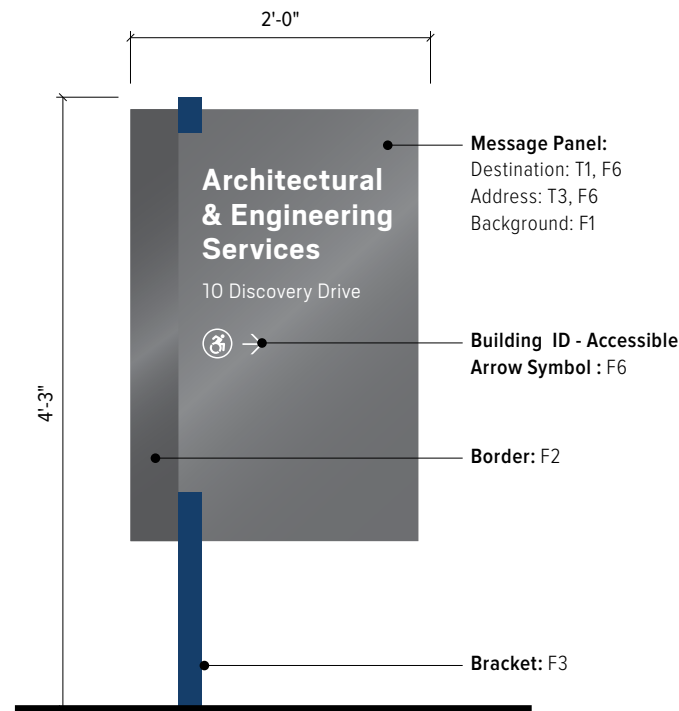

Date	15 May 2017
Project No.	UCONN-046
Phase	CID
Project Title	University of Connecticut Campus Wayfinding

Sign Type J2
Secondary Building ID,
Freestanding

CID.77

TWO TWELVE

902 BROADWAY
 FLOOR 20
 NEW YORK, NY
 10010/6002
 212 254/6670 T
 212 254/6614 F

For Planning & Coordination Only –
 Not for Construction

This document and the entirety of its
 contents are property of 212/Harakawa
 Inc. and/or Two Twelve Associates, Inc.
 No part of this document shall be
 duplicated, disseminated, distributed
 or used for any purpose without
 express written permission.

Do not use for final construction. Sign
 fabricator to verify and be responsible
 for all dimensions and work conditions
 and inform this office of variations prior
 to performing work. Written dimensions
 govern over scaled dimensions.

No.	Revisions

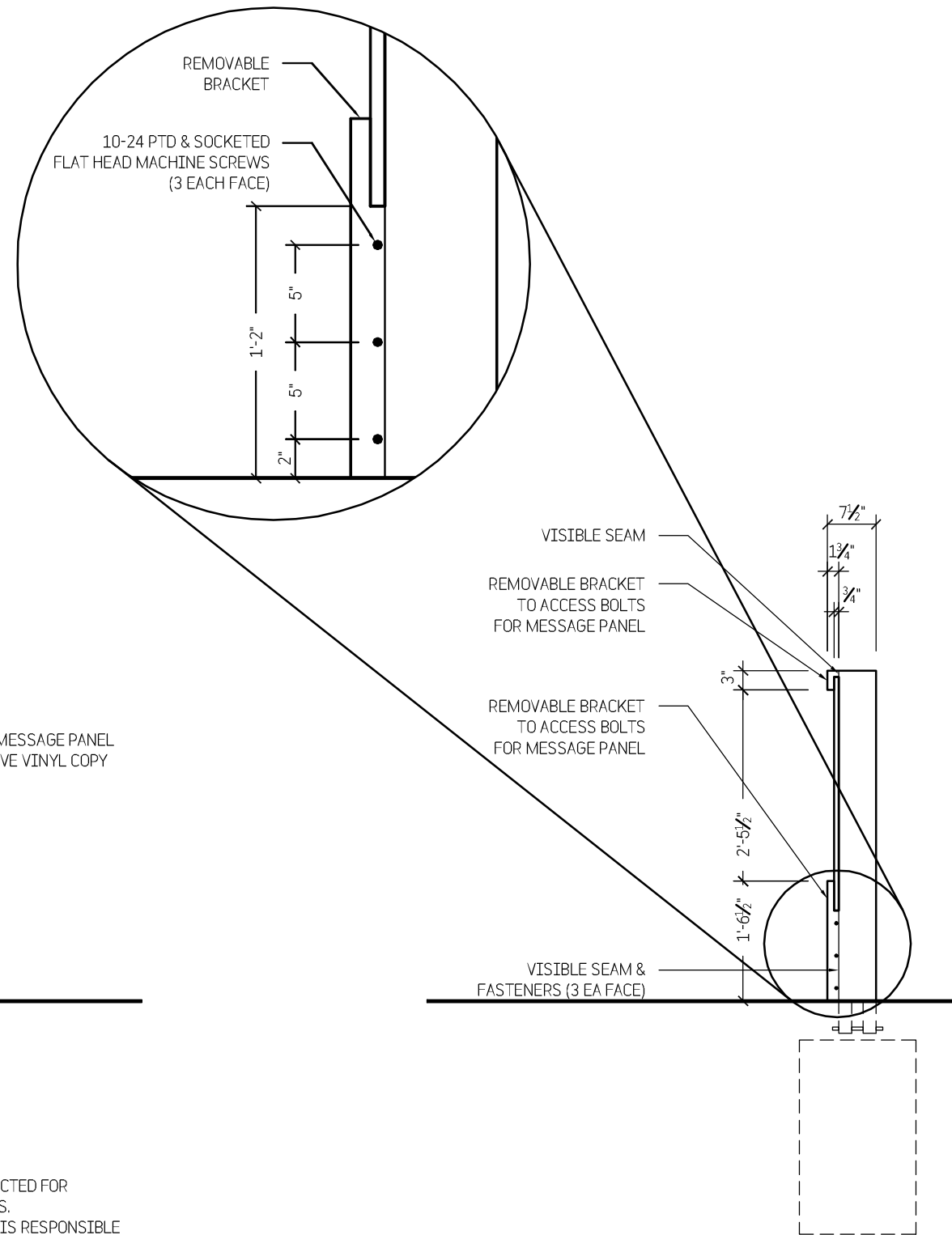
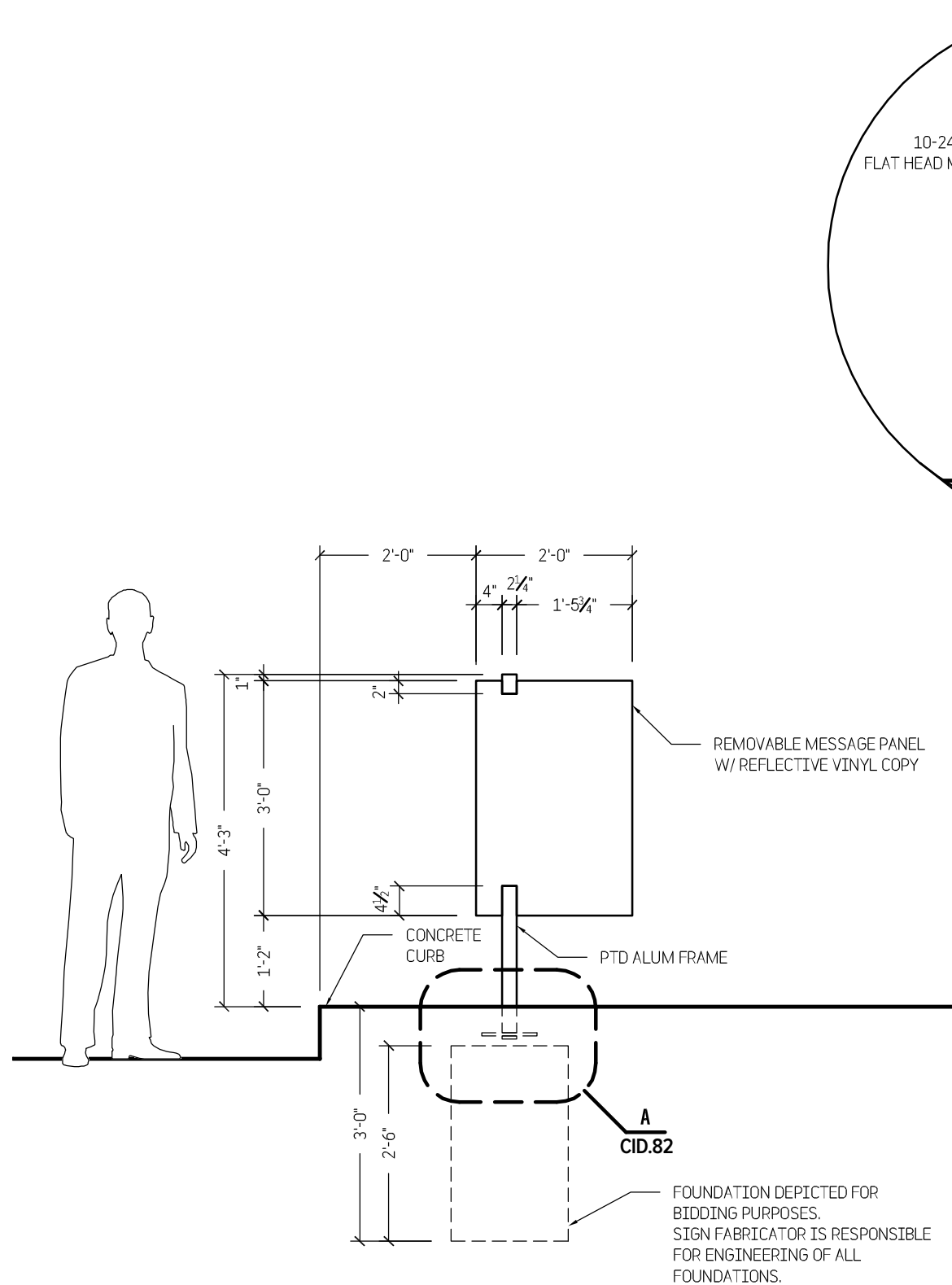

Date 15 May 2017

Project No. UCONN-046

Phase CID

Project Title
 University of Connecticut
 Campus Wayfinding

Sign Type J2
Secondary Building ID,
Freestanding

CID.78

TWO TWELVE

902 BROADWAY
 FLOOR 20
 NEW YORK, NY
 10010/6002
 212 254/6670 T
 212 254/6614 F

For Planning & Coordination Only –
 Not for Construction

This document and the entirety of its
 contents are property of 212/Harakawa
 Inc. and/or Two Twelve Associates, Inc.
 No part of this document shall be
 duplicated, disseminated, distributed
 or used for any purpose without
 express written permission.

Do not use for final construction. Sign
 fabricator to verify and be responsible
 for all dimensions and work conditions
 and inform this office of variations prior
 to performing work. Written dimensions
 govern over scaled dimensions.

No.	Revisions

Date 15 May 2017

Project No. UCONN-046

Phase CID

Project Title
 University of Connecticut
 Campus Wayfinding

Sign Type J2
 Secondary Building ID,
 Freestanding

CID.79

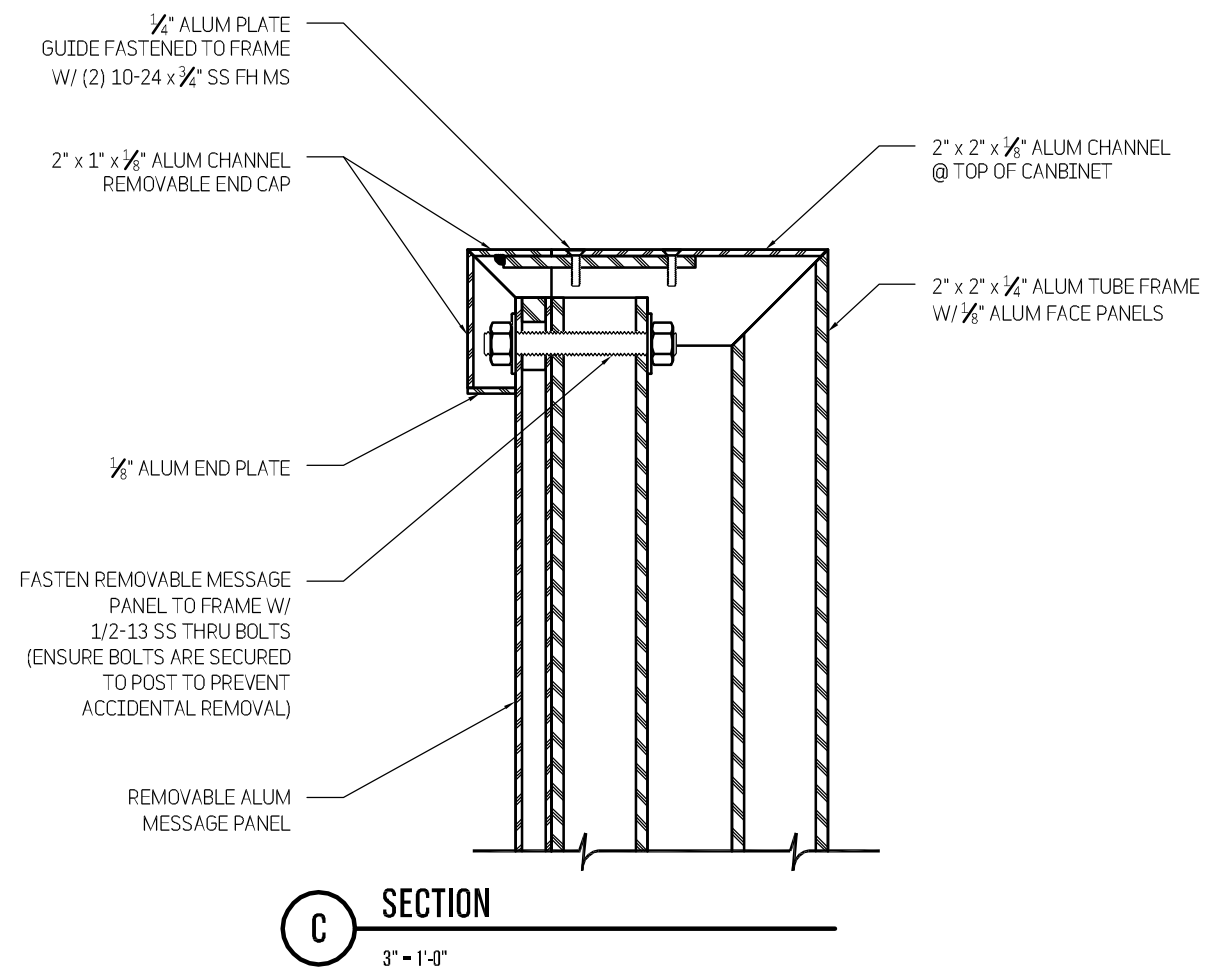
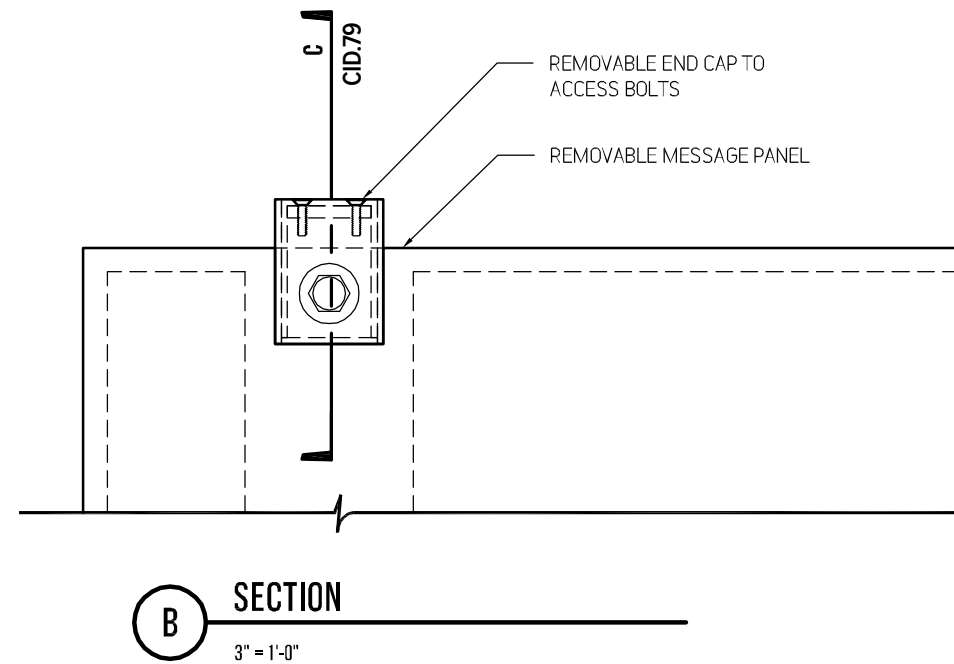
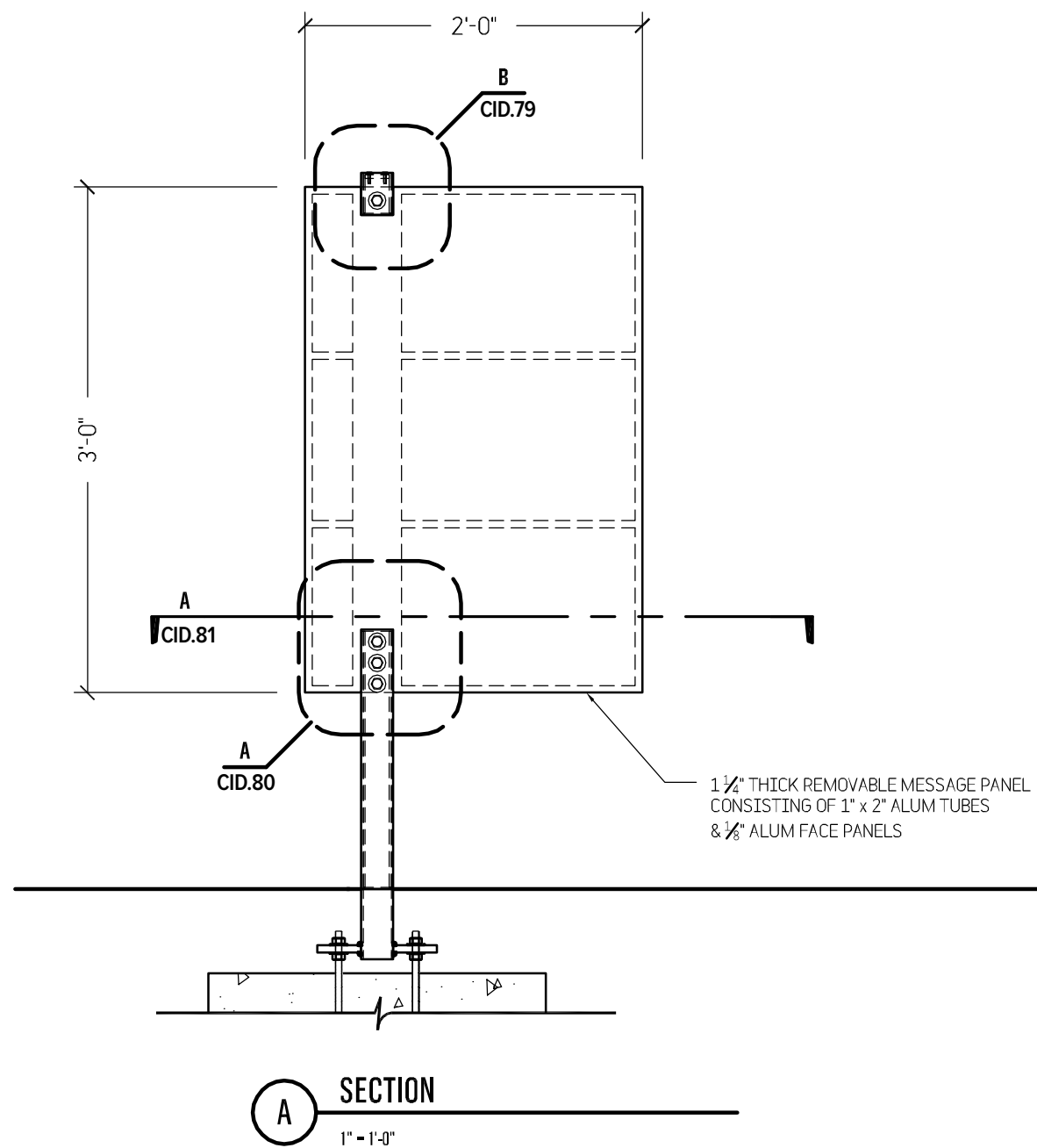

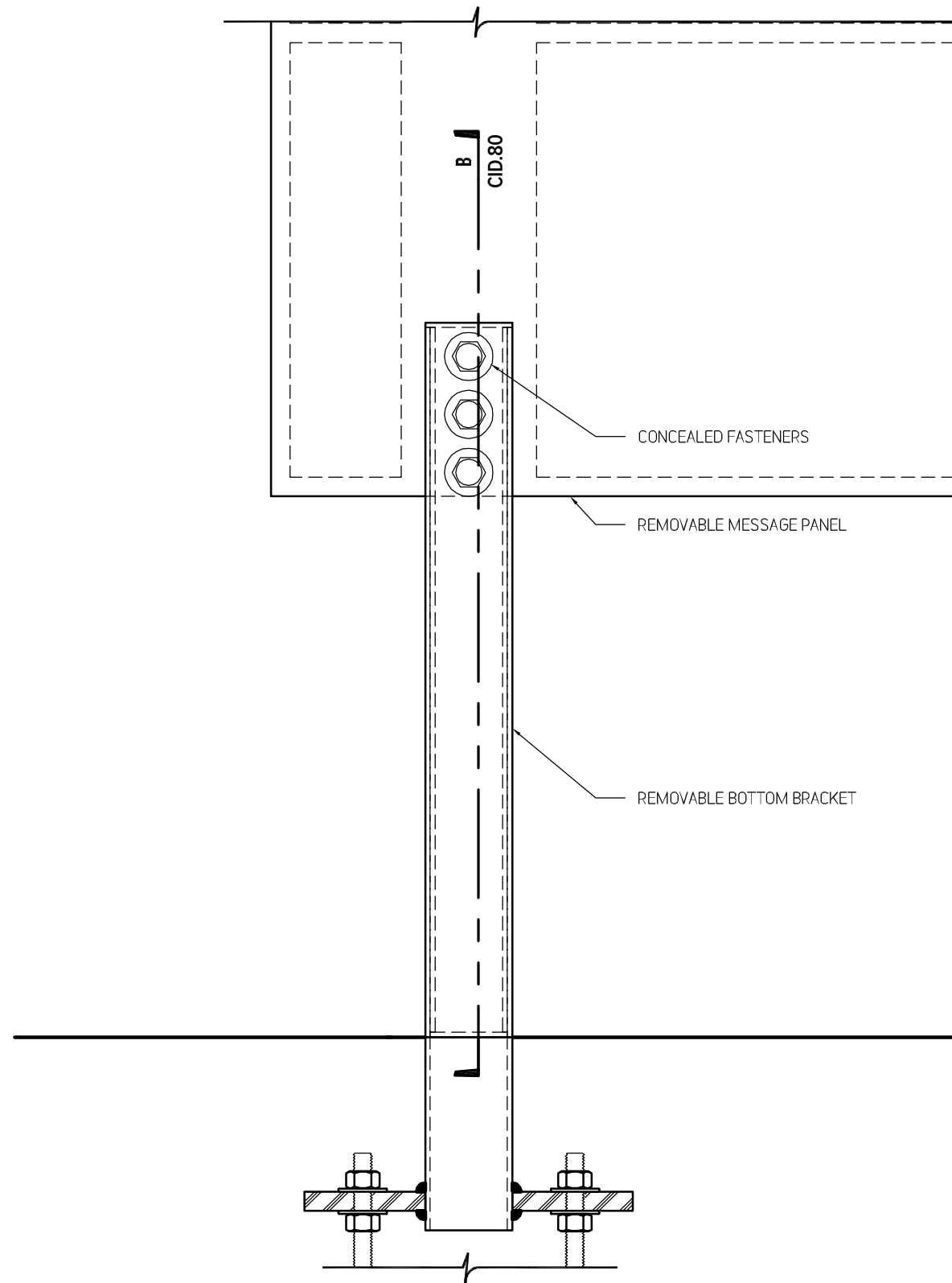

A SECTION
3" = 1'-0"

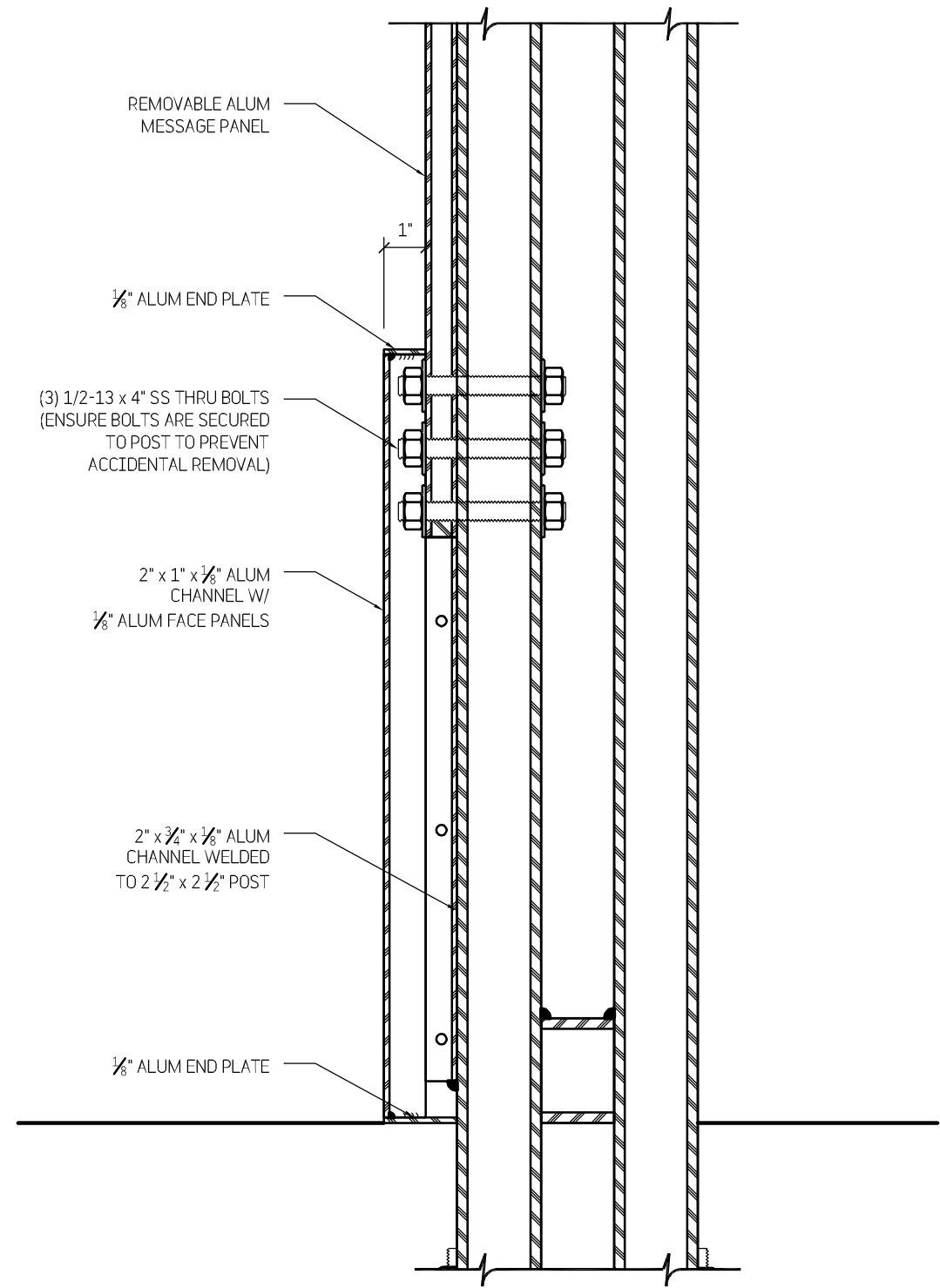

B SECTION
3" = 1'-0"

TWO TWELVE

902 BROADWAY
FLOOR 20
NEW YORK, NY
10010/6002
212 254/6670 T
212 254/6614 F

For Planning & Coordination Only –
Not for Construction

This document and the entirety of its
contents are property of 212/Harakawa
Inc. and/or Two Twelve Associates, Inc.
No part of this document shall be
duplicated, disseminated, distributed
or used for any purpose without
express written permission.

Do not use for final construction. Sign
fabricator to verify and be responsible
for all dimensions and work conditions
and inform this office of variations prior
to performing work. Written dimensions
govern over scaled dimensions.

No.	Revisions
-----	-----------

Date 15 May 2017

Project No. UCONN-046

Phase CID

Project Title
University of Connecticut
Campus Wayfinding

Sign Type J2
Secondary Building ID,
Freestanding

CID.80

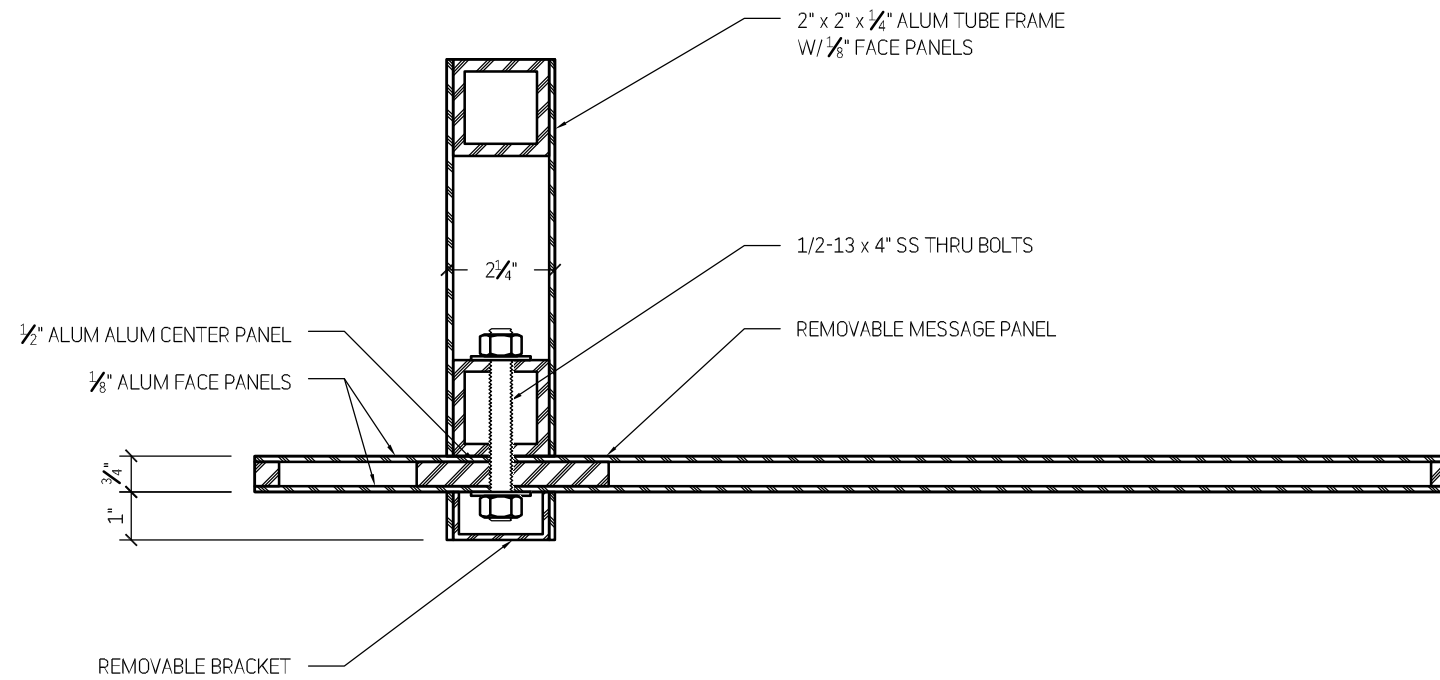

A SECTION
3" - 1'-0"

TWO TWELVE

902 BROADWAY
FLOOR 20
NEW YORK, NY
10010/6002
212 254/6670 T
212 254/6614 F

For Planning & Coordination Only –
Not for Construction

This document and the entirety of its contents are property of 212/Harakawa Inc. and/or Two Twelve Associates, Inc. No part of this document shall be duplicated, disseminated, distributed or used for any purpose without express written permission.

Do not use for final construction. Sign fabricator to verify and be responsible for all dimensions and work conditions and inform this office of variations prior to performing work. Written dimensions govern over scaled dimensions.

No.	Revisions
-----	-----------

Date 15 May 2017

Project No. UCONN-046

Phase CID

Project Title

University of Connecticut
Campus Wayfinding

**Sign Type J2
Secondary Building ID,
Freestanding**

CID.81

TWO TWELVE

902 BROADWAY
 FLOOR 20
 NEW YORK, NY
 10010/6002
 212 254/6670 T
 212 254/6614 F

For Planning & Coordination Only –
 Not for Construction

This document and the entirety of its
 contents are property of 212/Harakawa
 Inc. and/or Two Twelve Associates, Inc.
 No part of this document shall be
 duplicated, disseminated, distributed
 or used for any purpose without
 express written permission.

Do not use for final construction. Sign
 fabricator to verify and be responsible
 for all dimensions and work conditions
 and inform this office of variations prior
 to performing work. Written dimensions
 govern over scaled dimensions.

No.	Revisions

Date 15 May 2017

Project No. UCONN-046

Phase CID

Project Title
 University of Connecticut
 Campus Wayfinding

Sign Type J2
Secondary Building ID,
Freestanding

CID.82

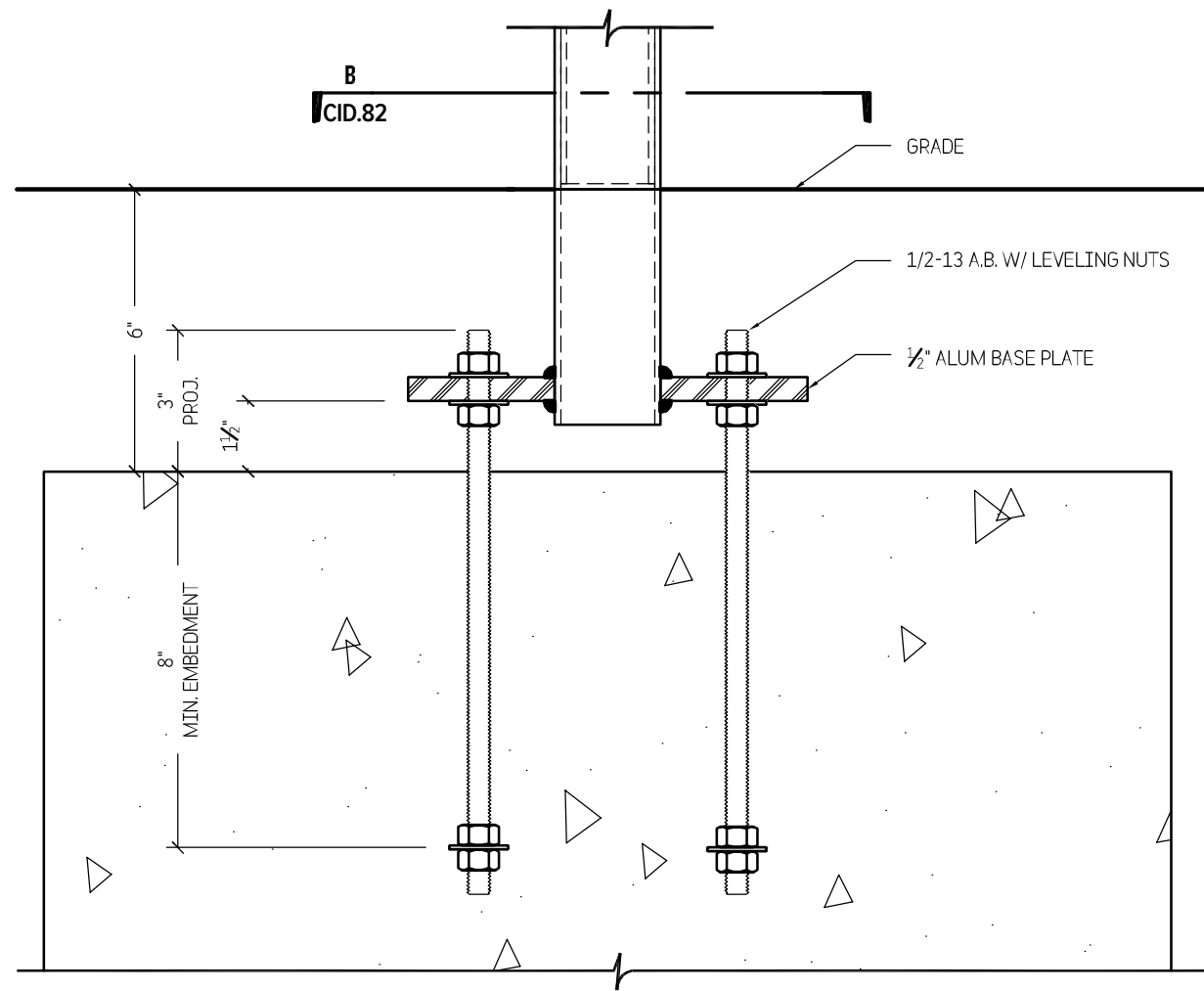

A SECTION
 3" = 1'-0"

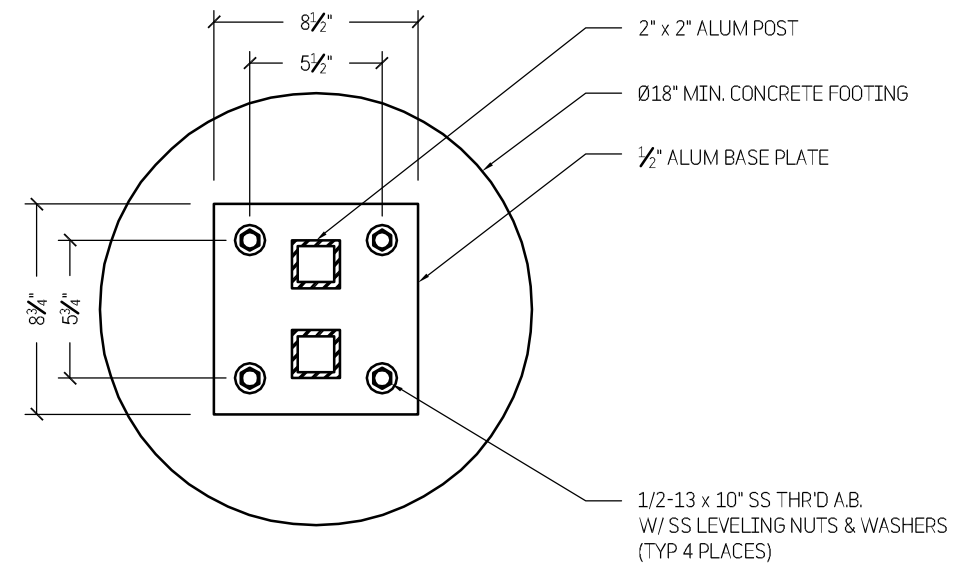

B SECTION
 1 1/2" = 1'-0"

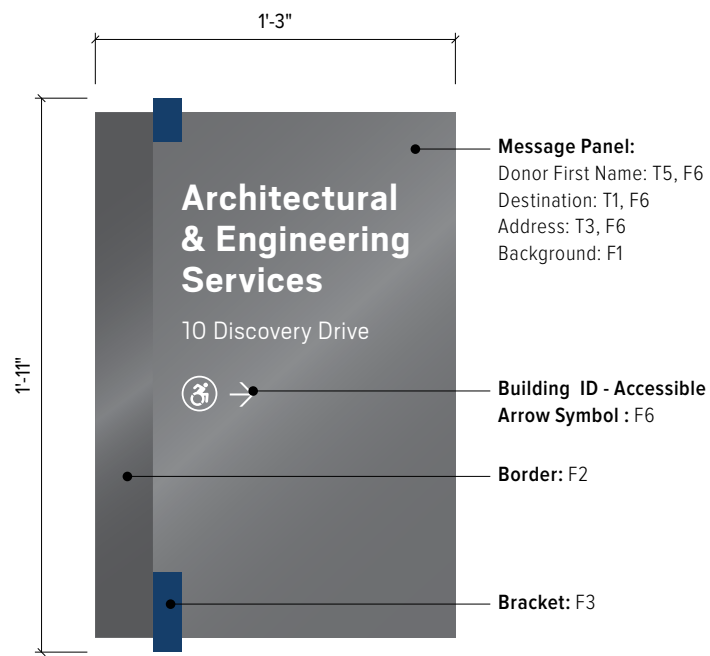

1 Elevation - Sign Type J3
 1 1/2" = 1'-0"

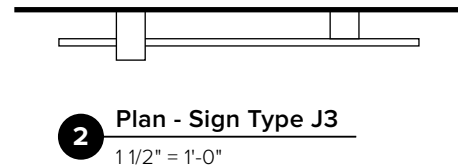

2 Plan - Sign Type J3
 1 1/2" = 1'-0"

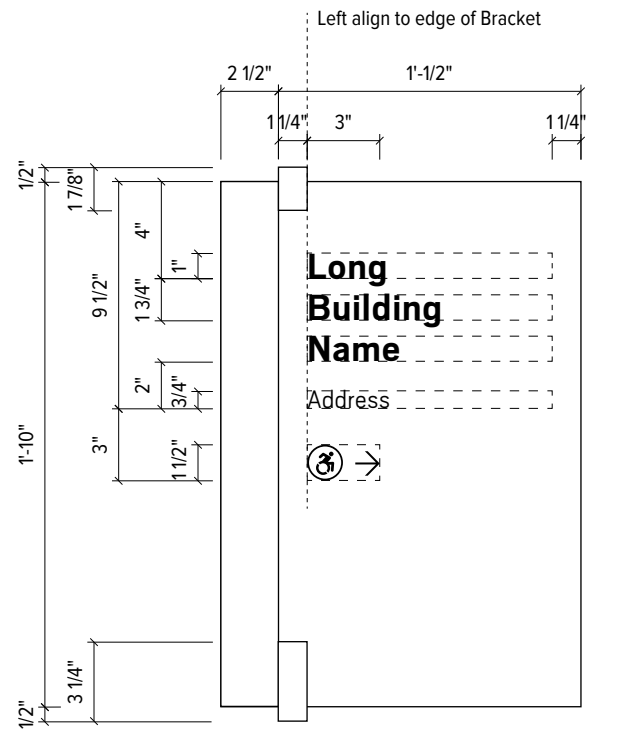

3 Graphic Layout - Sign Type J3
 1 1/2" = 1'-0"

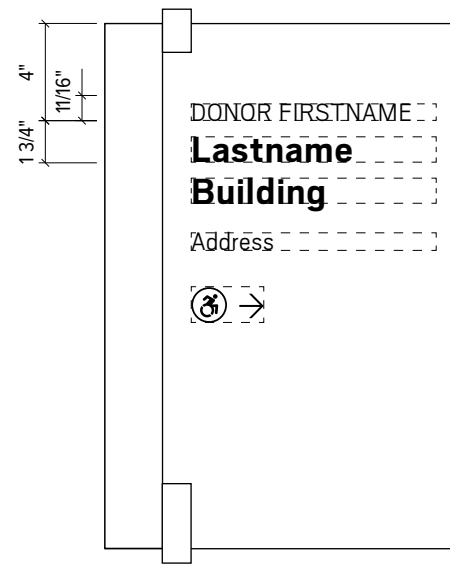

4 Graphic Layout - Sign Type J3, w/ Donor Name
 1 1/2" = 1'-0"

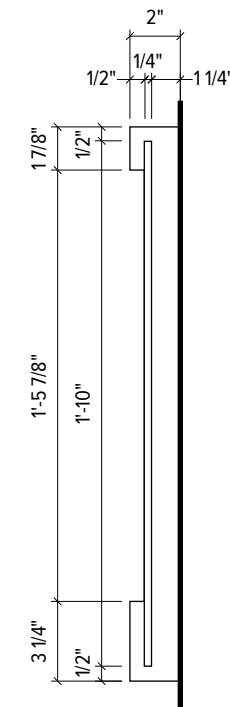

5 Side View - Sign Type J3
 1 1/2" = 1'-0"

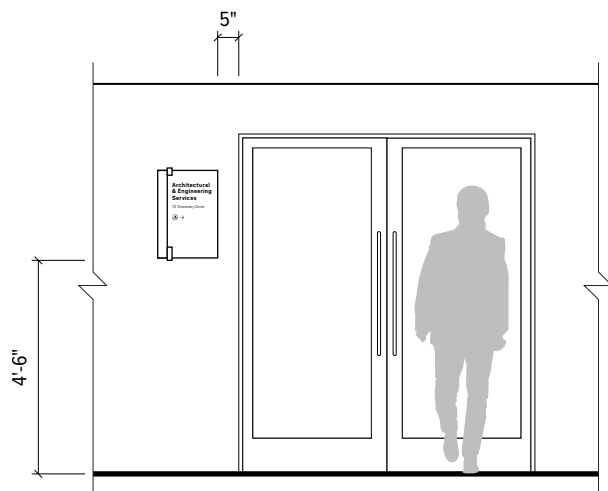

6 Installation Elevation - Sign Type J3
 1/4" = 1'-0"

TWO TWELVE

902 BROADWAY
 FLOOR 20
 NEW YORK, NY
 10010/6002
 212 254/6670 T
 212 254/6614 F

For Planning & Coordination Only –
 Not for Construction

This document and the entirety of its contents are property of 212/Harakawa Inc. and/or Two Twelve Associates, Inc. No part of this document shall be duplicated, disseminated, distributed or used for any purpose without express written permission.

Do not use for final construction. Sign fabricator to verify and be responsible for all dimensions and work conditions and inform this office of variations prior to performing work. Written dimensions govern over scaled dimensions.

No.	Revisions
-----	-----------

Date 15 May 2017
 Project No. UCONN-046
 Phase CID
 Project Title
 University of Connecticut
 Campus Wayfinding

Sign Type J3
Secondary Building ID,
Wall Mounted

CID.83

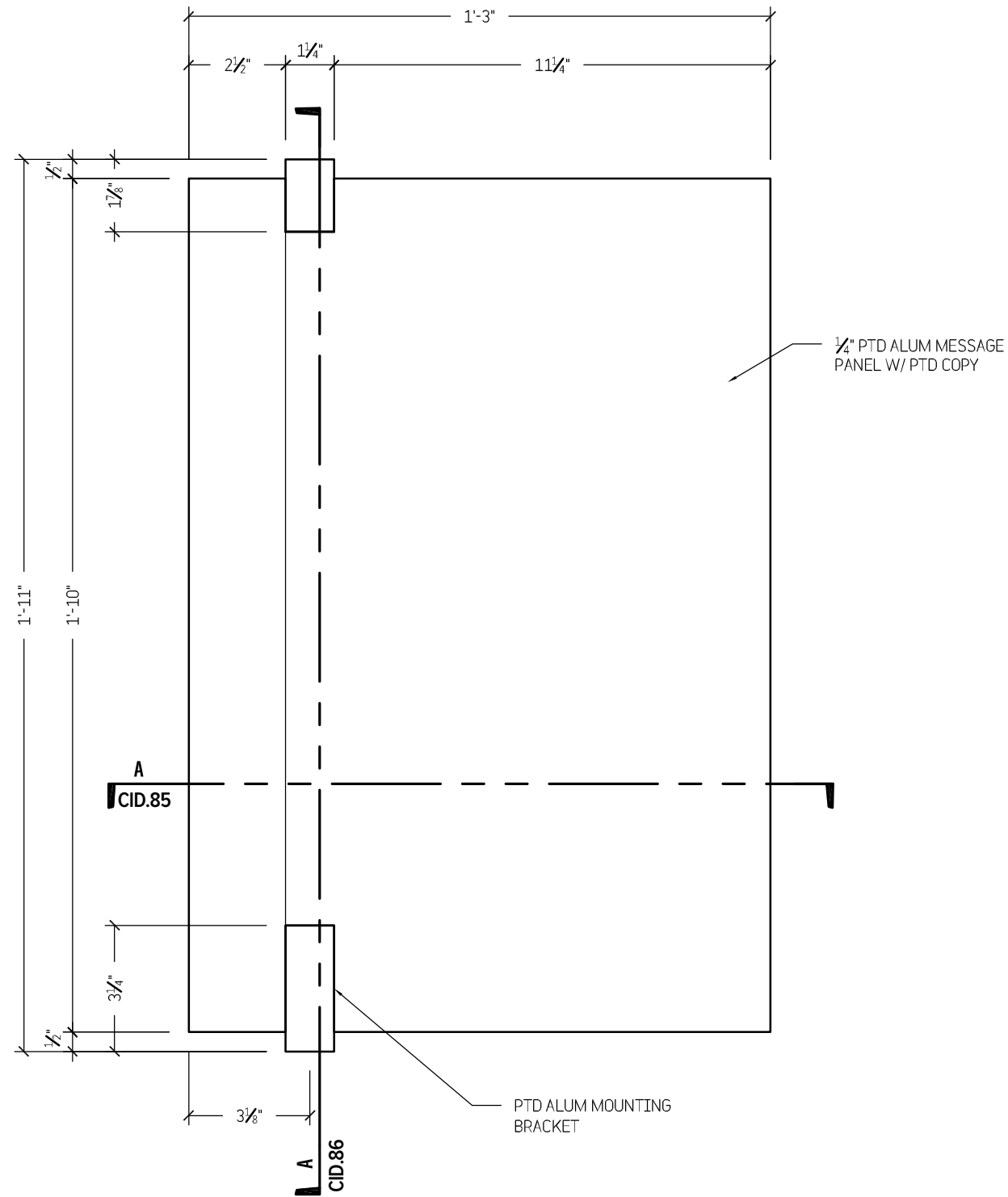

1 ELEVATION
3" - 1'-0"

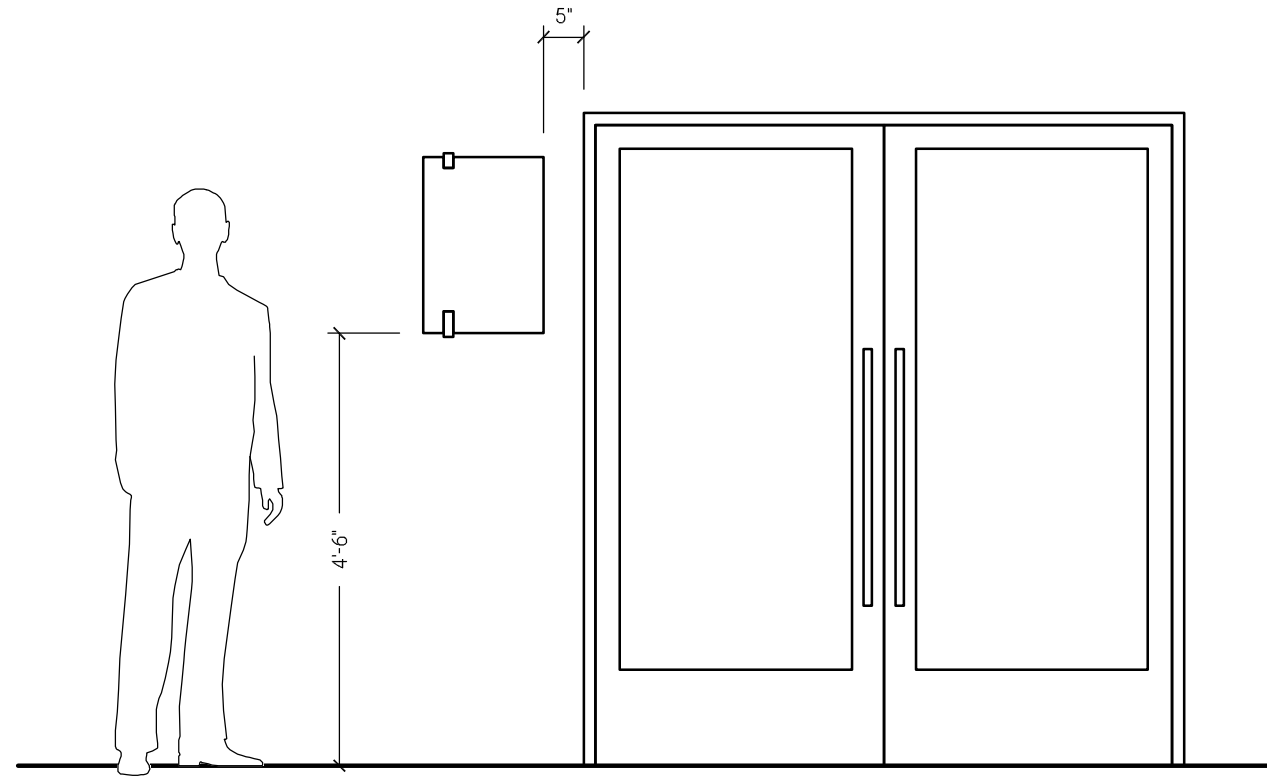

2 INSTALL ELEVATION
1/2" - 1'-0"

TWO TWELVE

902 BROADWAY
FLOOR 20
NEW YORK, NY
10010/6002
212 254/6670 T
212 254/6614 F

For Planning & Coordination Only –
Not for Construction

This document and the entirety of its contents are property of 212/Harakawa Inc. and/or Two Twelve Associates, Inc. No part of this document shall be duplicated, disseminated, distributed or used for any purpose without express written permission.

Do not use for final construction. Sign fabricator to verify and be responsible for all dimensions and work conditions and inform this office of variations prior to performing work. Written dimensions govern over scaled dimensions.

No.	Revisions

Date 15 May 2017

Project No. UCONN-046

Phase CID

Project Title
University of Connecticut
Campus Wayfinding

Sign Type J3
Secondary Building ID,
Wall Mounted

CID.84

TWO TWELVE

902 BROADWAY
 FLOOR 20
 NEW YORK, NY
 10010/6002
 212 254/6670 T
 212 254/6614 F

For Planning & Coordination Only –
 Not for Construction

This document and the entirety of its
 contents are property of 212/Harakawa
 Inc. and/or Two Twelve Associates, Inc.
 No part of this document shall be
 duplicated, disseminated, distributed
 or used for any purpose without
 express written permission.

Do not use for final construction. Sign
 fabricator to verify and be responsible
 for all dimensions and work conditions
 and inform this office of variations prior
 to performing work. Written dimensions
 govern over scaled dimensions.

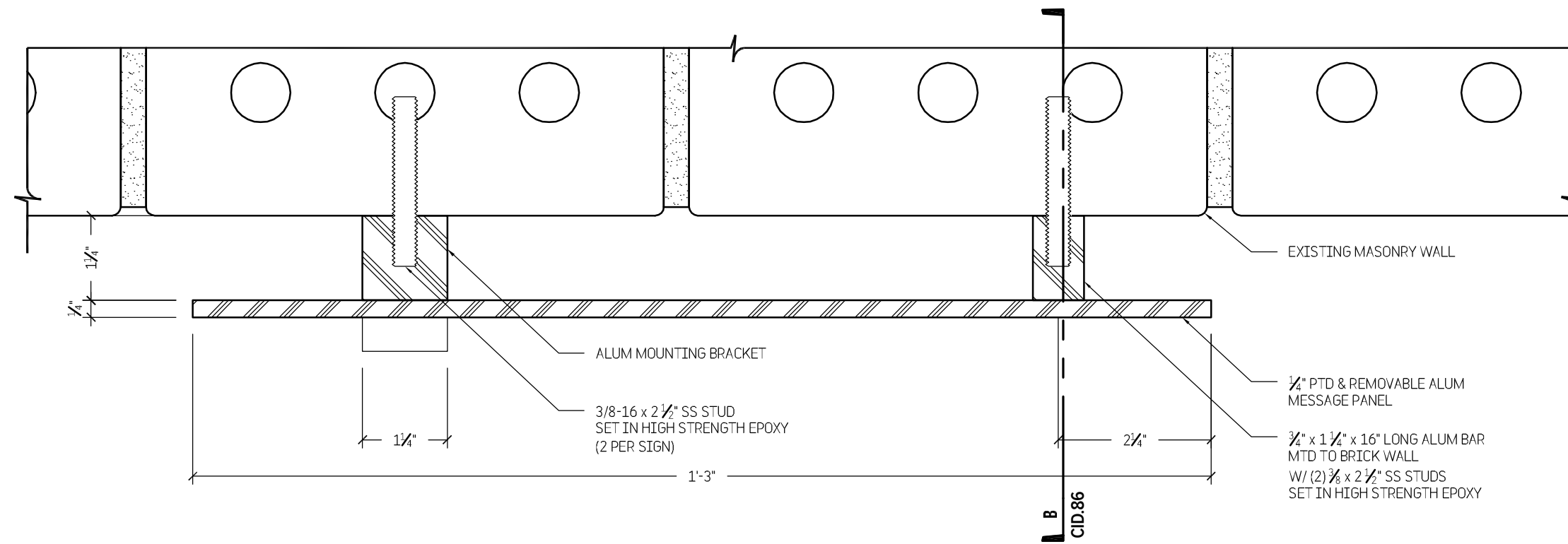

A SECTION
 Half Size

No.	Revisions
-----	-----------

Date 15 May 2017

Project No. UCONN-046

Phase CID

Project Title
 University of Connecticut
 Campus Wayfinding

**Sign Type J3
 Secondary Building ID,
 Wall Mounted**

CID.85

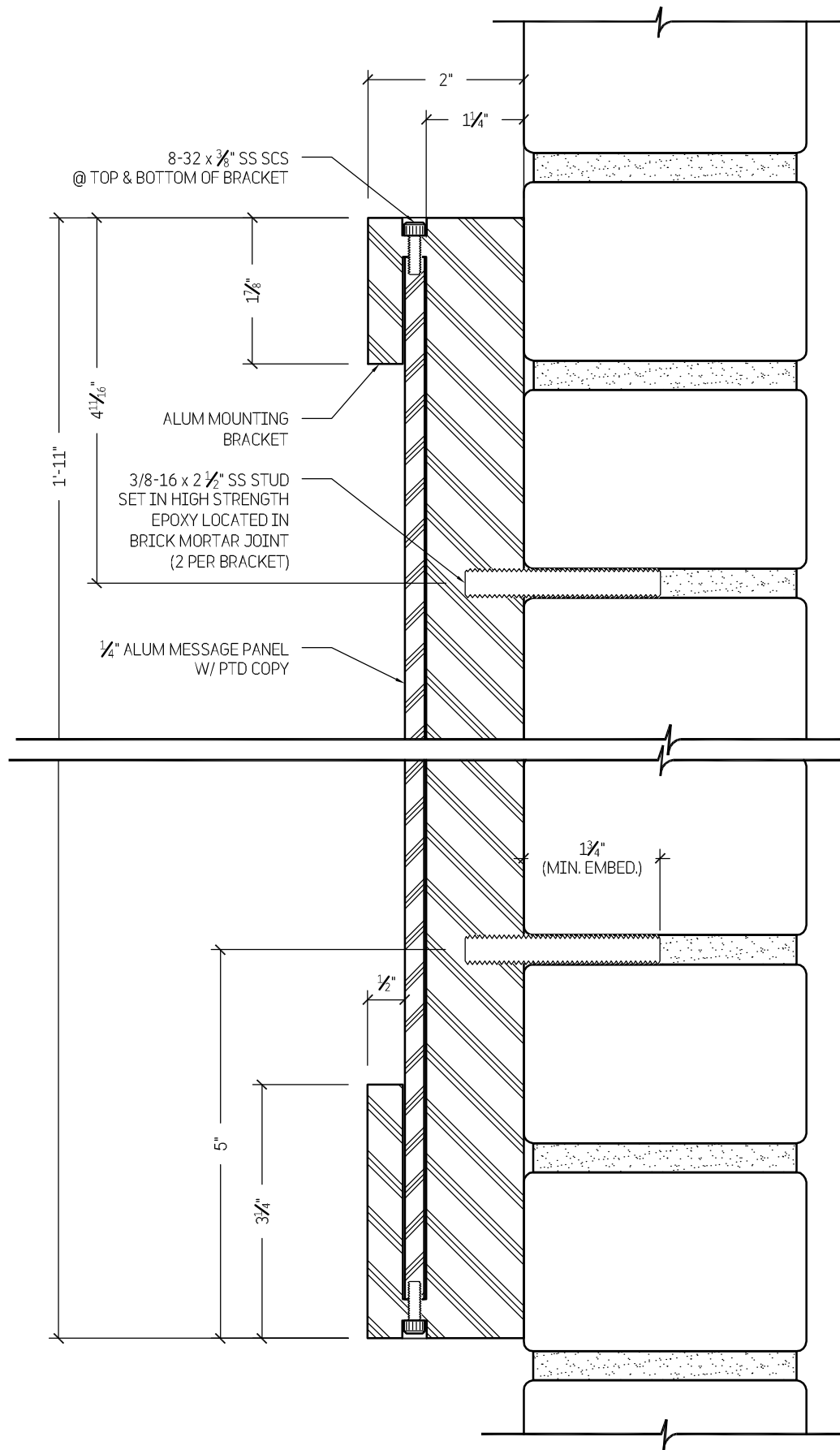

A SECTION
Half Size

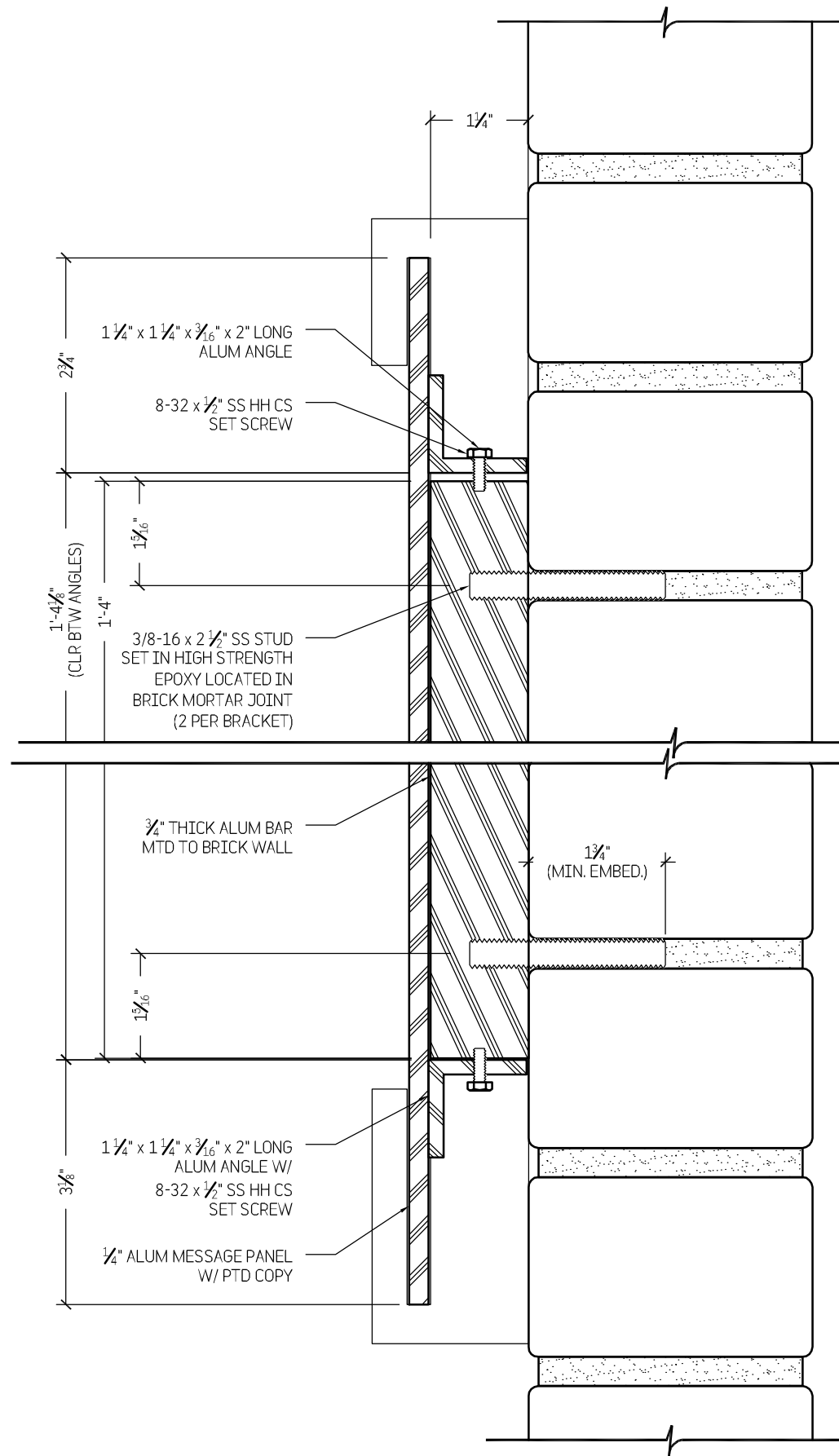

B SECTION
Half Size

TWO TWELVE

902 BROADWAY
FLOOR 20
NEW YORK, NY
10010/6002
212 254/6670 T
212 254/6614 F

For Planning & Coordination Only –
Not for Construction

This document and the entirety of its contents are property of 212/Harakawa Inc. and/or Two Twelve Associates, Inc. No part of this document shall be duplicated, disseminated, distributed or used for any purpose without express written permission.

Do not use for final construction. Sign fabricator to verify and be responsible for all dimensions and work conditions and inform this office of variations prior to performing work. Written dimensions govern over scaled dimensions.

No.	Revisions

Date 15 May 2017

Project No. UCONN-046

Phase CID

Project Title
University of Connecticut
Campus Wayfinding

Sign Type J3
Secondary Building ID,
Wall Mounted

CID.86

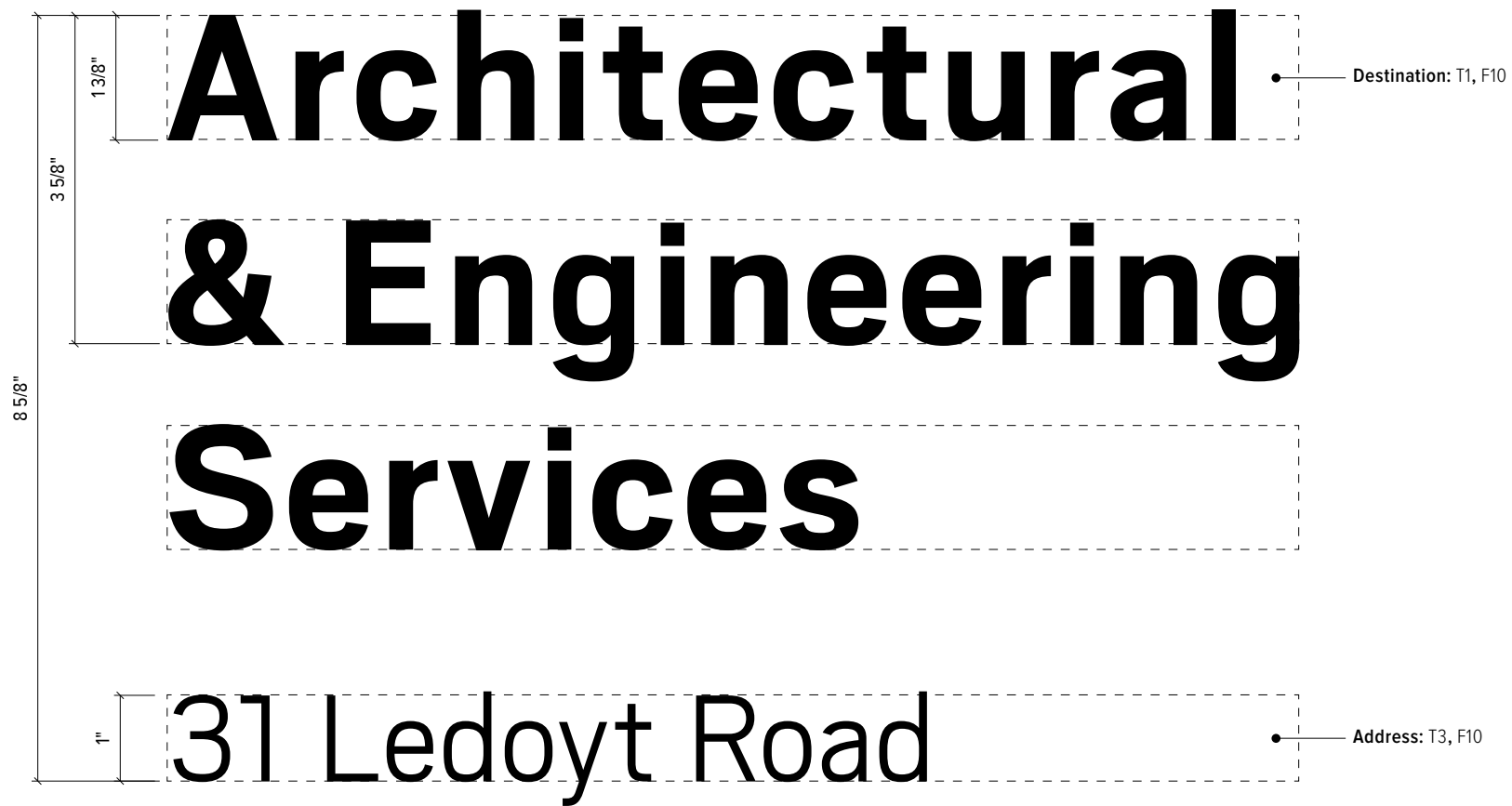

1 Graphic Layout - Sign Type J4
6" = 1'-0"

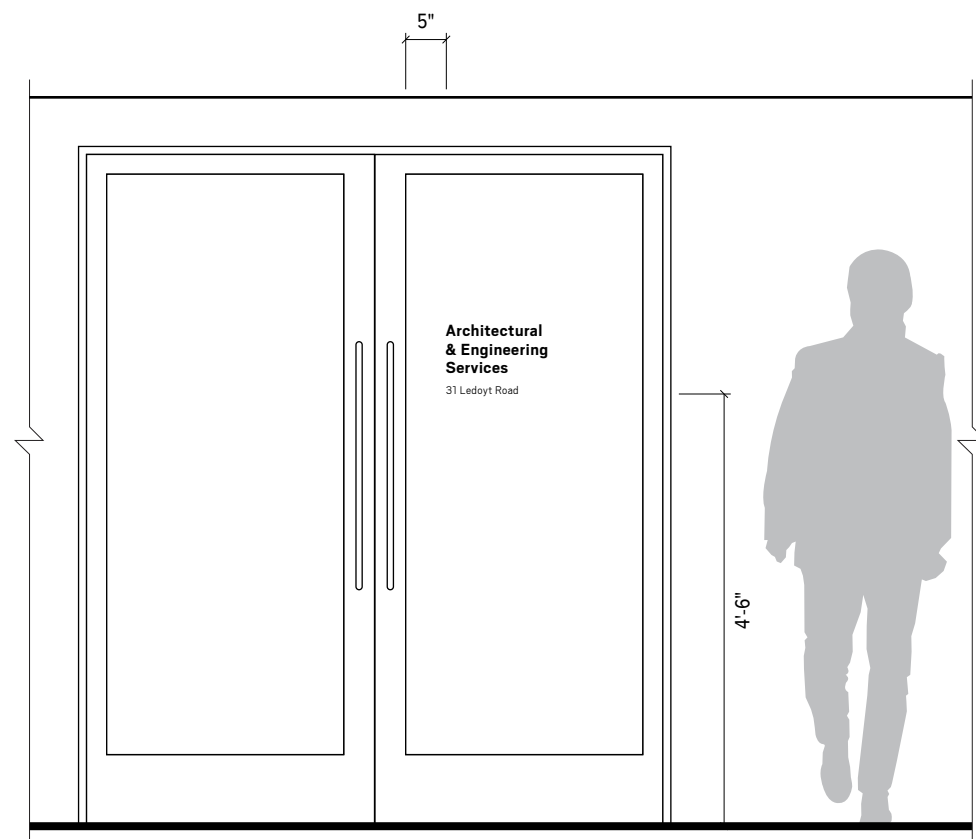

2 Installation Elevation - Sign Type J4
1/2" = 1'-0"

TWO TWELVE

902 BROADWAY
FLOOR 20
NEW YORK, NY
10010/6002
212 254/6670 T
212 254/6614 F

For Planning & Coordination Only –
Not for Construction

This document and the entirety of its contents are property of 212/Harakawa Inc. and/or Two Twelve Associates, Inc. No part of this document shall be duplicated, disseminated, distributed or used for any purpose without express written permission.

Do not use for final construction. Sign fabricator to verify and be responsible for all dimensions and work conditions and inform this office of variations prior to performing work. Written dimensions govern over scaled dimensions.

No.	Revisions
-----	-----------

Date 15 May 2017

Project No. UCONN-046

Phase CID

Project Title
University of Connecticut
Campus Wayfinding

**Sign Type J4
Secondary Building ID,
Vinyl**

CID.87

TWO TWELVE

902 BROADWAY
FLOOR 20
NEW YORK, NY
10010/6002
212 254/6670 T
212 254/6614 F

For Planning & Coordination Only –
Not for Construction

This document and the entirety of its
contents are property of 212/Harakawa
Inc. and/or Two Twelve Associates, Inc.
No part of this document shall be
duplicated, disseminated, distributed
or used for any purpose without
express written permission.

Do not use for final construction. Sign
fabricator to verify and be responsible
for all dimensions and work conditions
and inform this office of variations prior
to performing work. Written dimensions
govern over scaled dimensions.

No.	Revisions
-----	-----------

Date	15 May 2017
------	-------------

Project No.	UCONN-046
-------------	-----------

Phase	CID
-------	-----

Project Title

University of Connecticut
Campus Wayfinding

Sign Type J4
Secondary Building ID,
Vinyl

CID.88

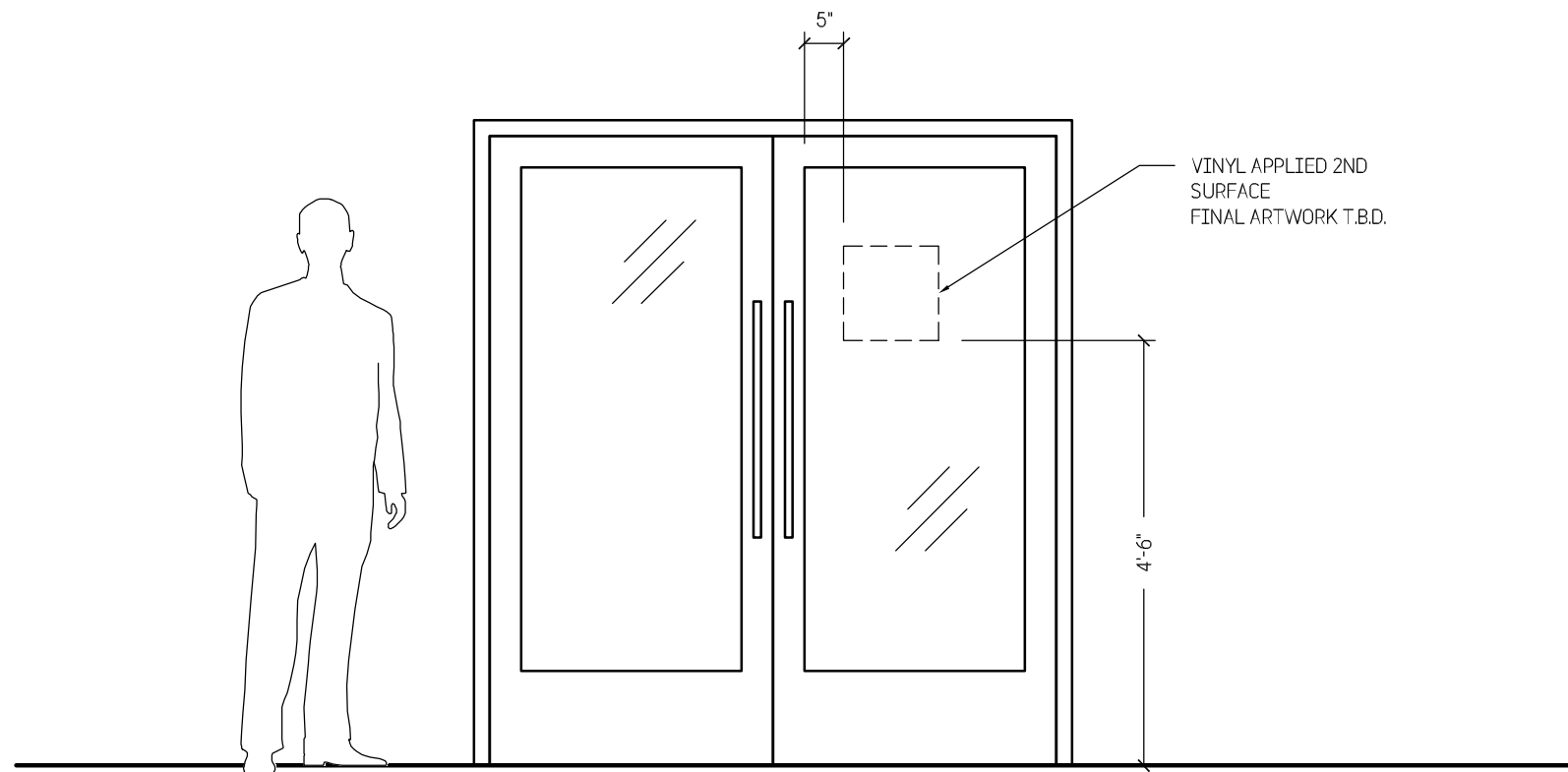

1 ELEVATION
1/2" = 1'-0"

TWO TWELVE

902 BROADWAY
 FLOOR 20
 NEW YORK, NY
 10010/6002
 212 254/6670 T
 212 254/6614 F

For Planning & Coordination Only –
 Not for Construction

This document and the entirety of its contents are property of 212/Harakawa Inc. and/or Two Twelve Associates, Inc. No part of this document shall be duplicated, disseminated, distributed or used for any purpose without express written permission.

Do not use for final construction. Sign fabricator to verify and be responsible for all dimensions and work conditions and inform this office of variations prior to performing work. Written dimensions govern over scaled dimensions.

No.	Revisions

Date 15 May 2017

Project No. UCONN-046

Phase CID

Project Title
 University of Connecticut
 Campus Wayfinding

Sign Type K
Accessible Pathway
Marker

CID.89

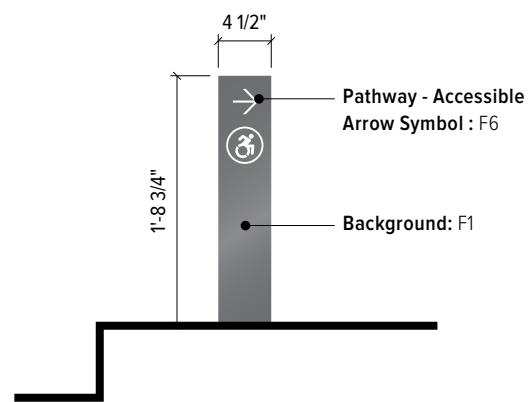

1 Elevation - Sign Type K
 3/4" = 1'-0"

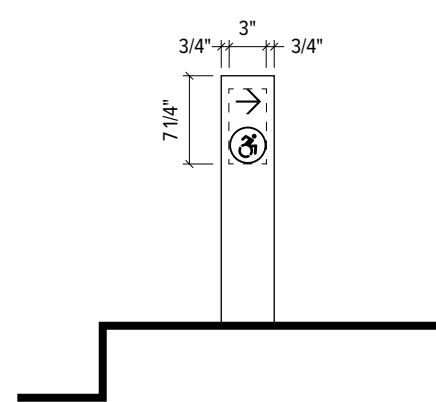

3 Graphic Layout - Sign Type K
 3/4" = 1'-0"

2 Plan - Sign Type K
 3/4" = 1'-0"

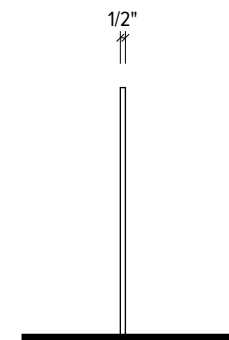

4 Side View - Sign Type K
 3/4" = 1'-0"

TWO TWELVE

902 BROADWAY
 FLOOR 20
 NEW YORK, NY
 10010/6002
 212 254/6670 T
 212 254/6614 F

For Planning & Coordination Only –
 Not for Construction

This document and the entirety of its
 contents are property of 212/Harakawa
 Inc. and/or Two Twelve Associates, Inc.
 No part of this document shall be
 duplicated, disseminated, distributed
 or used for any purpose without
 express written permission.

Do not use for final construction. Sign
 fabricator to verify and be responsible
 for all dimensions and work conditions
 and inform this office of variations prior
 to performing work. Written dimensions
 govern over scaled dimensions.

No.	Revisions

Date 15 May 2017

Project No. UCONN-046

Phase CID

Project Title
 University of Connecticut
 Campus Wayfinding

Sign Type K
Accessible Pathway
Marker

CID.90

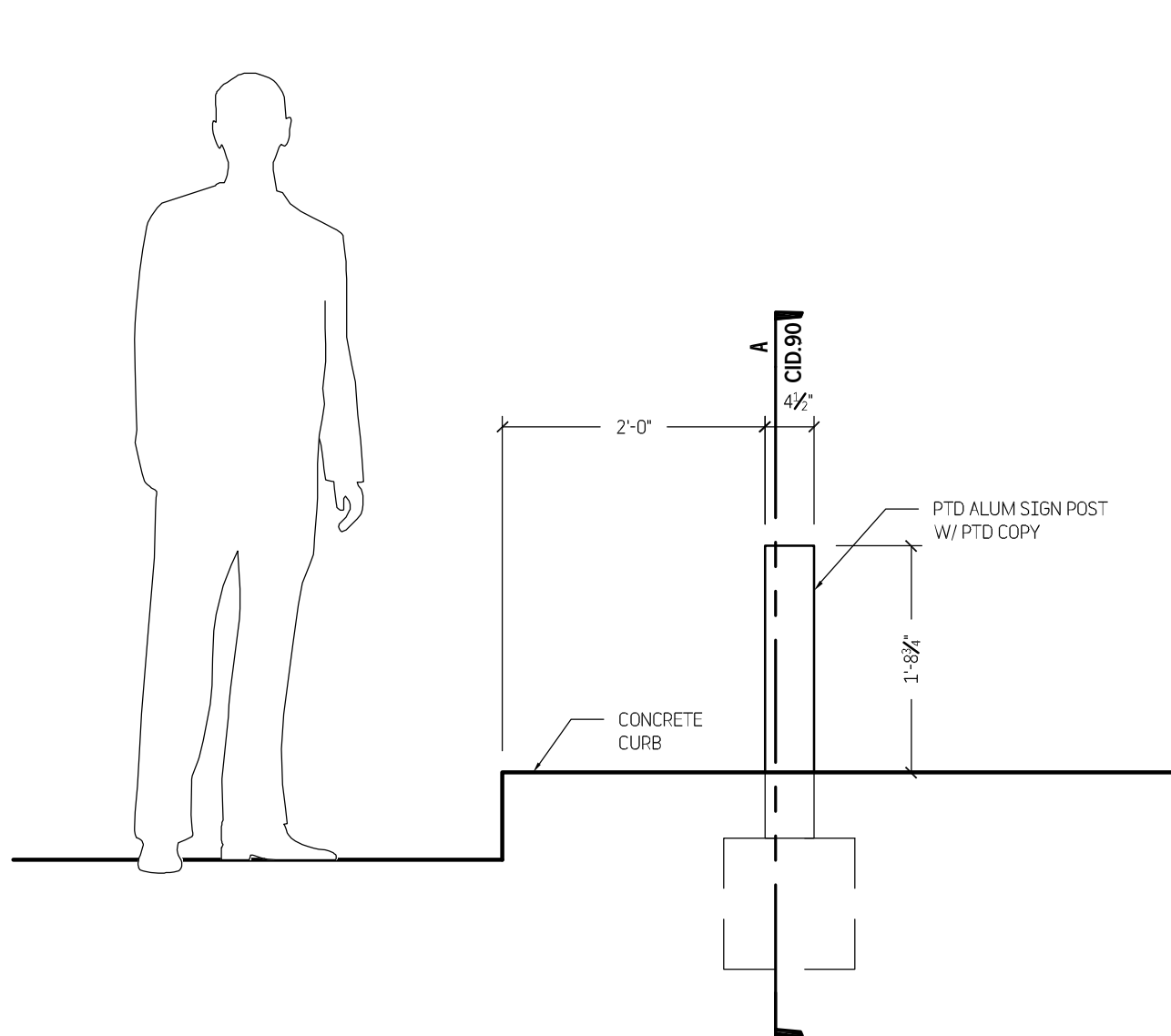

1 ELEVATION
 3/4" = 1'-0"

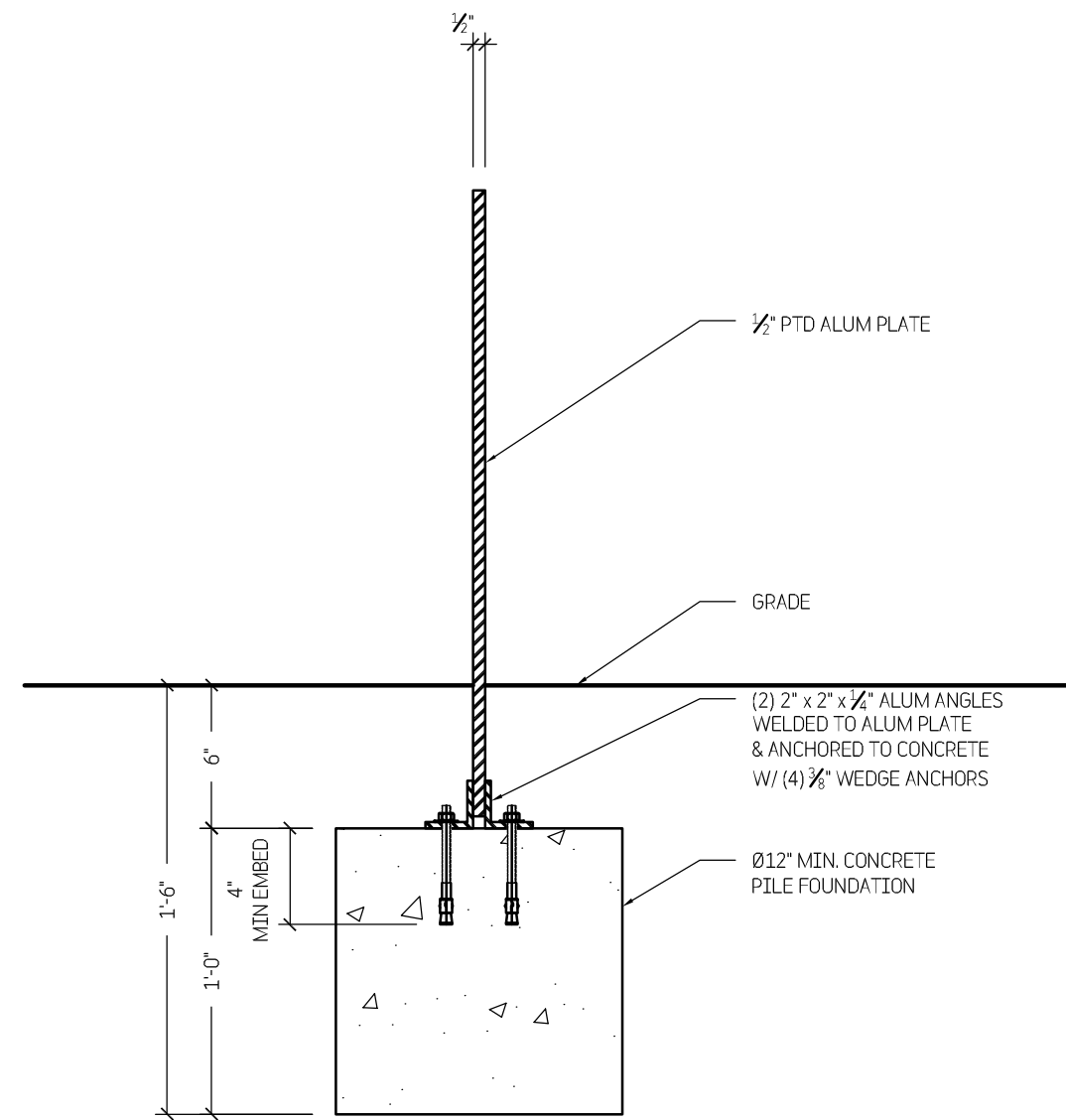

A SECTION
 3/4" = 1'-0"

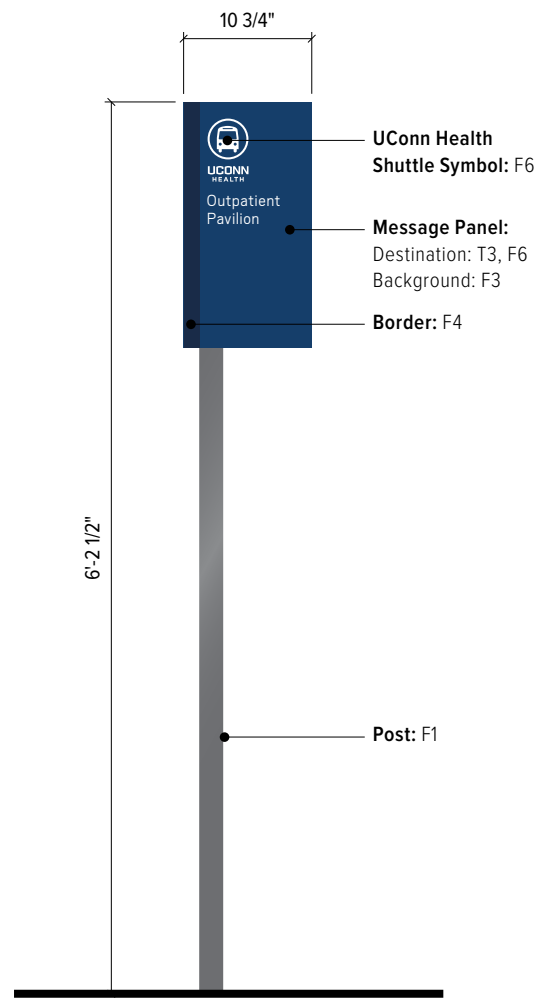

1 Elevation - Sign Type L
3/4" = 1'-0"

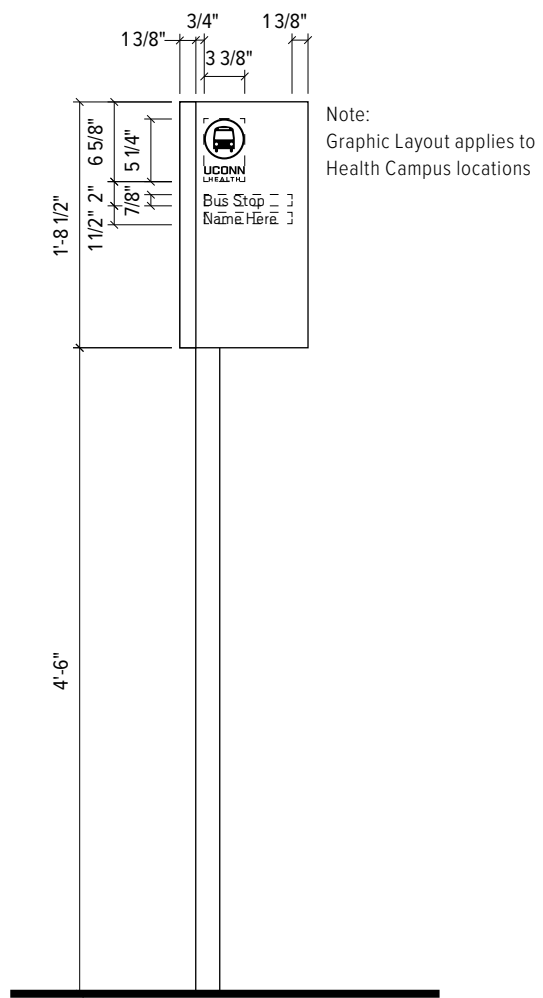

3 Graphic Layout - Sign Type L
3/4" = 1'-0"

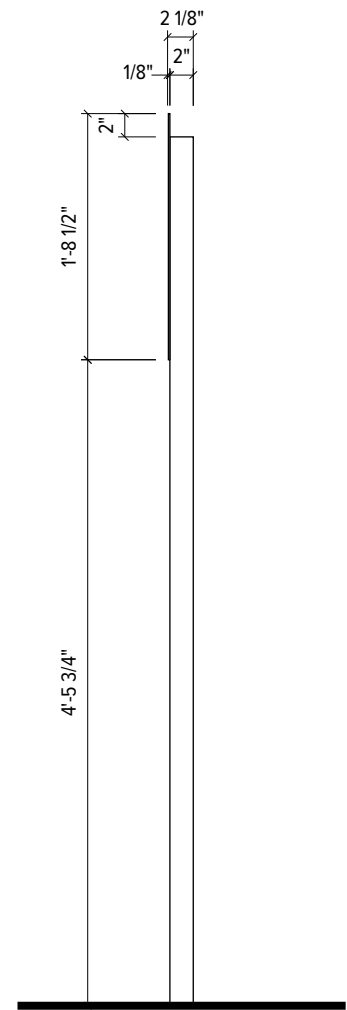

4 Side View - Sign Type L
3/4" = 1'-0"

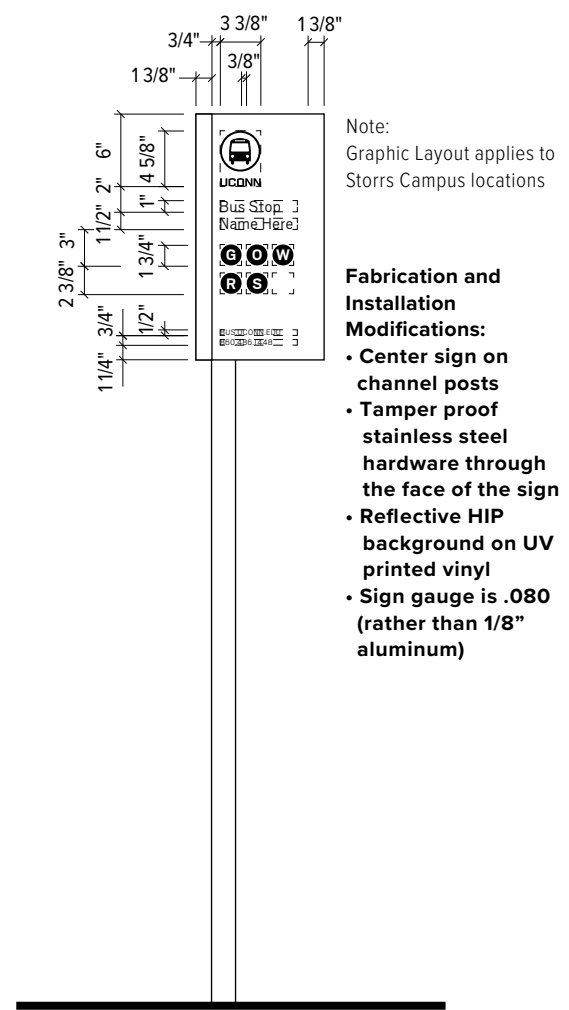

5 Alternate Graphic Layout - Sign Type L
3/4" = 1'-0"

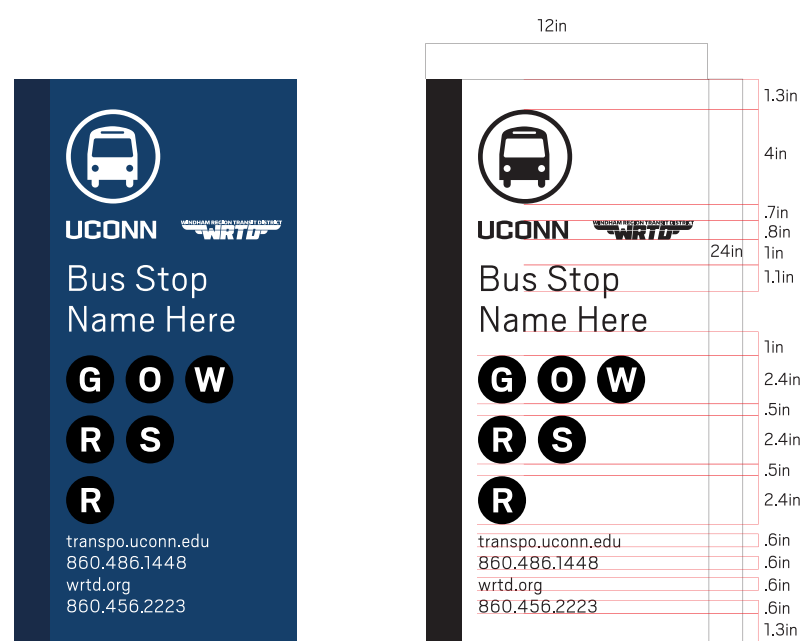
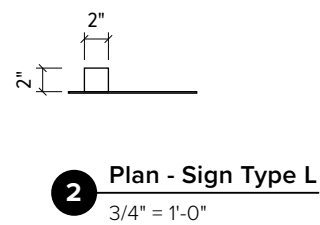

6 Alternate Graphic Layout - Larger Size - Sign Type L
3/4" = 1'-0"

Note:
Signs may be attached to other posts or mounted to shelter surfaces when requested and approved by University representative.

TWO TWELVE

902 BROADWAY
FLOOR 20
NEW YORK, NY
10010/6002
212 254/6670 T
212 254/6614 F

For Planning & Coordination Only –
Not for Construction

This document and the entirety of its contents are property of 212/Harakawa Inc. and/or Two Twelve Associates, Inc. No part of this document shall be duplicated, disseminated, distributed or used for any purpose without express written permission.

Do not use for final construction. Sign fabricator to verify and be responsible for all dimensions and work conditions and inform this office of variations prior to performing work. Written dimensions govern over scaled dimensions.

No.	Revisions

Date 15 May 2017

Project No. UCONN-046

Phase CID

Project Title

University of Connecticut
Campus Wayfinding

Sign Type L
Shuttle Bus Stop ID

CID.91

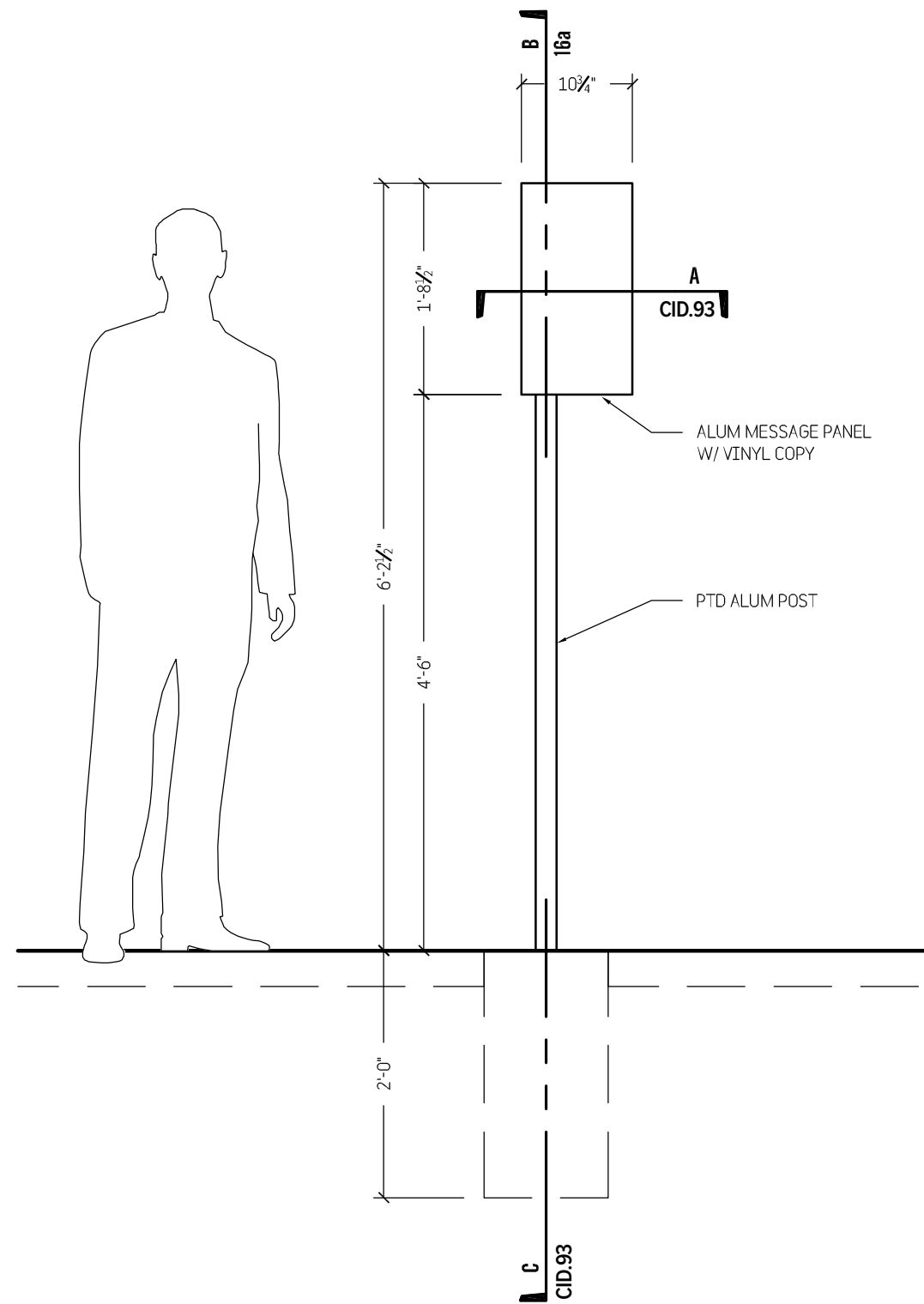

1 ELEVATION
3/4" = 1'-0"

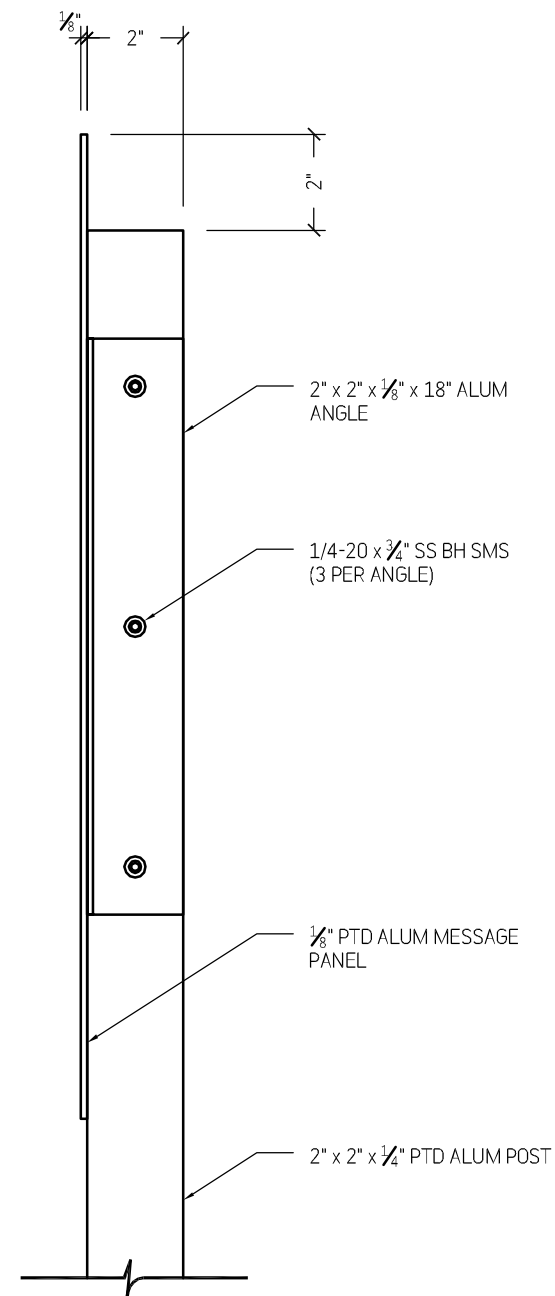

2 SIDE VIEW
3" = 1'-0"

TWO TWELVE

902 BROADWAY
FLOOR 20
NEW YORK, NY
10010/6002
212 254/6670 T
212 254/6614 F

For Planning & Coordination Only –
Not for Construction

This document and the entirety of its
contents are property of 212/Harakawa
Inc. and/or Two Twelve Associates, Inc.
No part of this document shall be
duplicated, disseminated, distributed
or used for any purpose without
express written permission.

Do not use for final construction. Sign
fabricator to verify and be responsible
for all dimensions and work conditions
and inform this office of variations prior
to performing work. Written dimensions
govern over scaled dimensions.

No.	Revisions

Date 15 May 2017

Project No. UCONN-046

Phase CID

Project Title
University of Connecticut
Campus Wayfinding

Sign Type L
Shuttle Bus Stop ID

CID.92

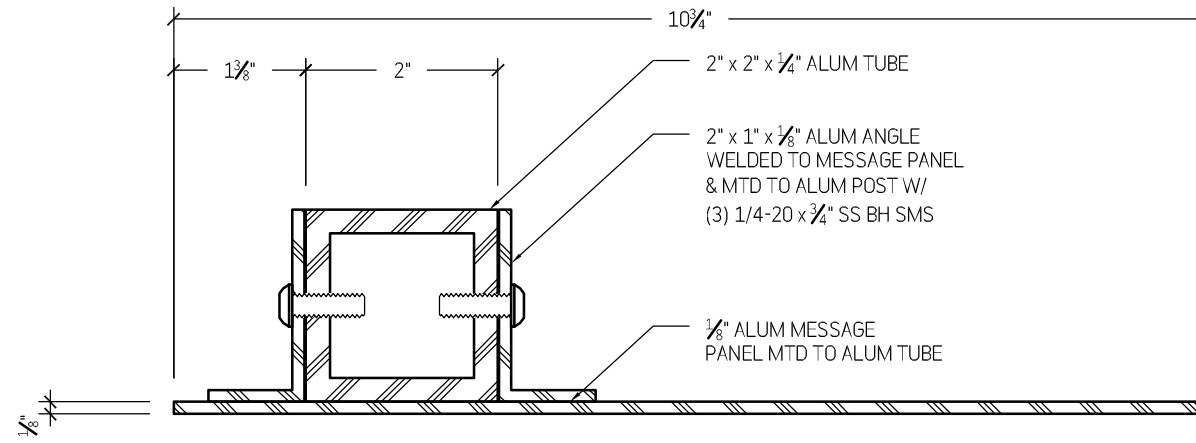

A SECTION
Half Size

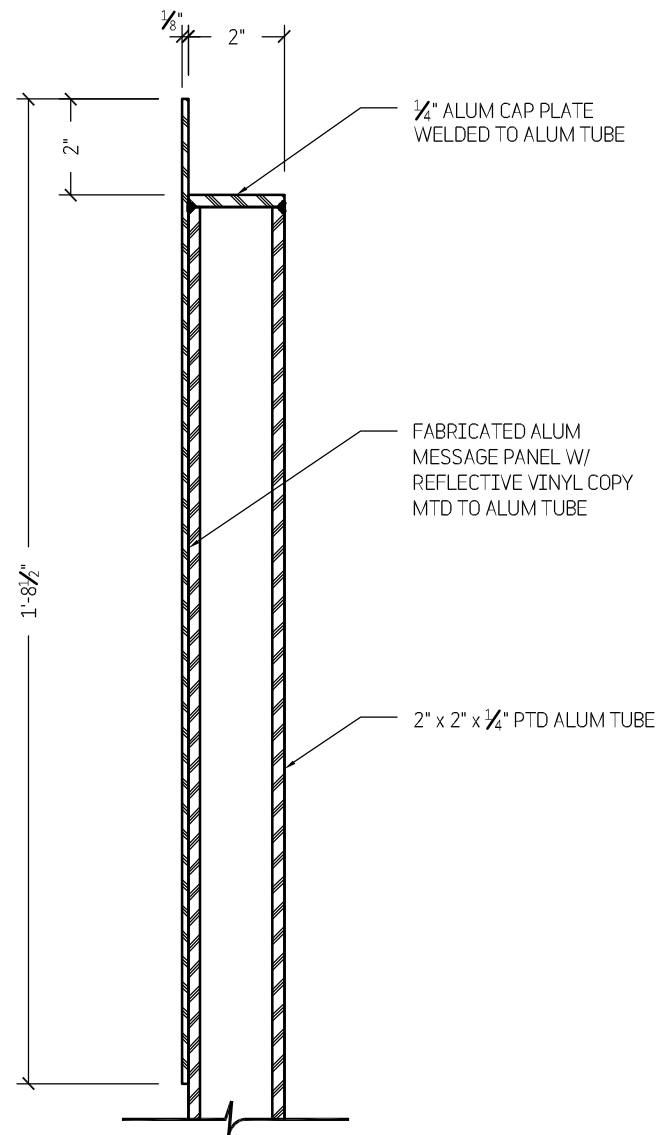

B SECTION
3\"/>

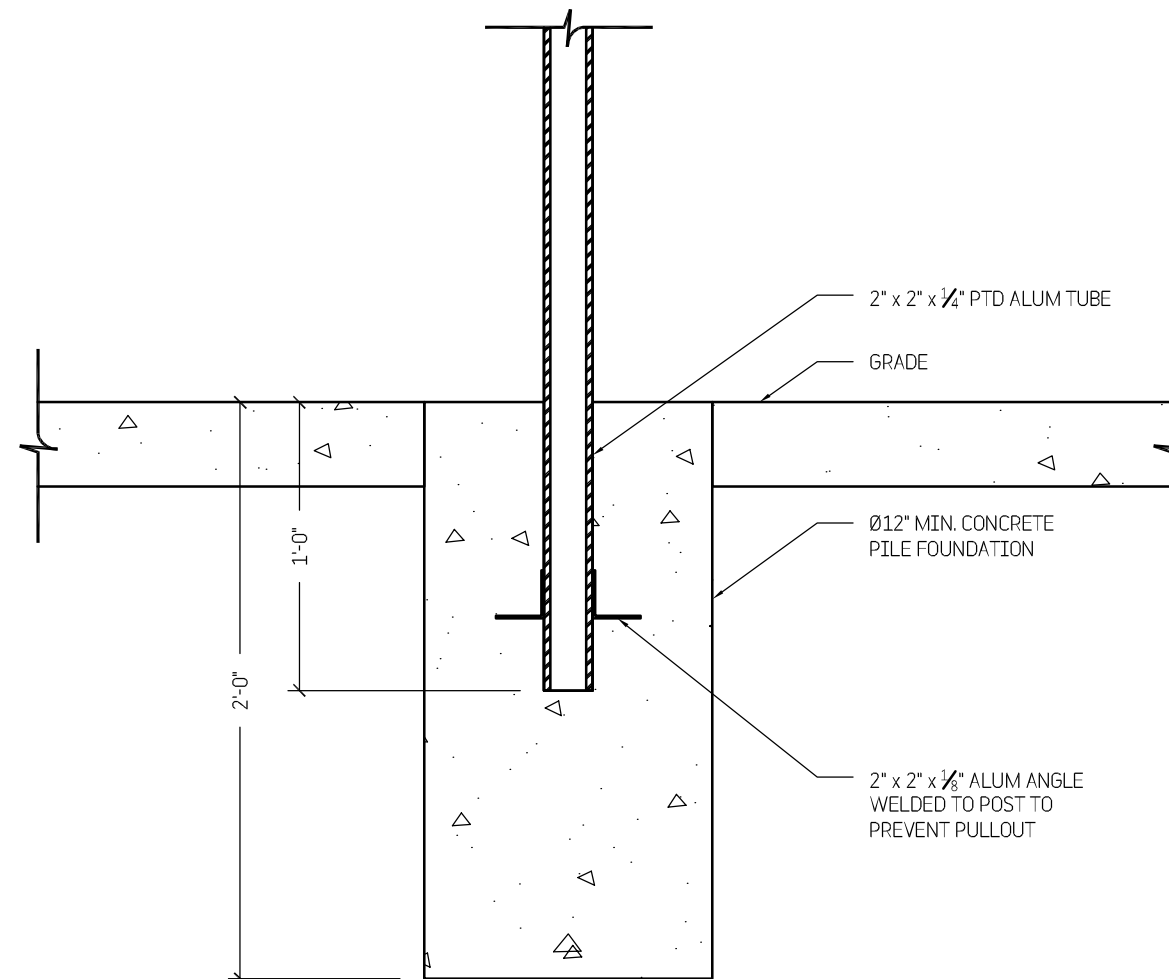

C SECTION
1 1/2\"/>

TWO TWELVE

902 BROADWAY
FLOOR 20
NEW YORK, NY
10010/6002
212 254/6670 T
212 254/6614 F

For Planning & Coordination Only –
Not for Construction

This document and the entirety of its contents are property of 212/Harakawa Inc. and/or Two Twelve Associates, Inc. No part of this document shall be duplicated, disseminated, distributed or used for any purpose without express written permission.

Do not use for final construction. Sign fabricator to verify and be responsible for all dimensions and work conditions and inform this office of variations prior to performing work. Written dimensions govern over scaled dimensions.

No.	Revisions

Date 15 May 2017

Project No. UCONN-046

Phase CID

Project Title
University of Connecticut
Campus Wayfinding

Sign Type L
Shuttle Bus Stop ID

CID.93



	<small>This Drawing Or Copy Is Submitted For Your Personal Use In Connection With The Project That We're Planning For You. It Is Not To Be Copied, Reproduced Or Exhibited To Anyone Outside Of Your Department Without Written Permission From: </small>	Signs mounted on metal U-channel posts.	Date: 8/26/19	<ul style="list-style-type: none"> I have verified the accuracy of all graphics shown with respect to sizes and content. The specifications are correct and represent our order requirements exactly. I authorize release to production according to this approved submittal. 	Page Number:
			Scale: 1:3		

Drawing Title
Sign Type P
Regulatory, Vehicular

Drawing No.
CID.94

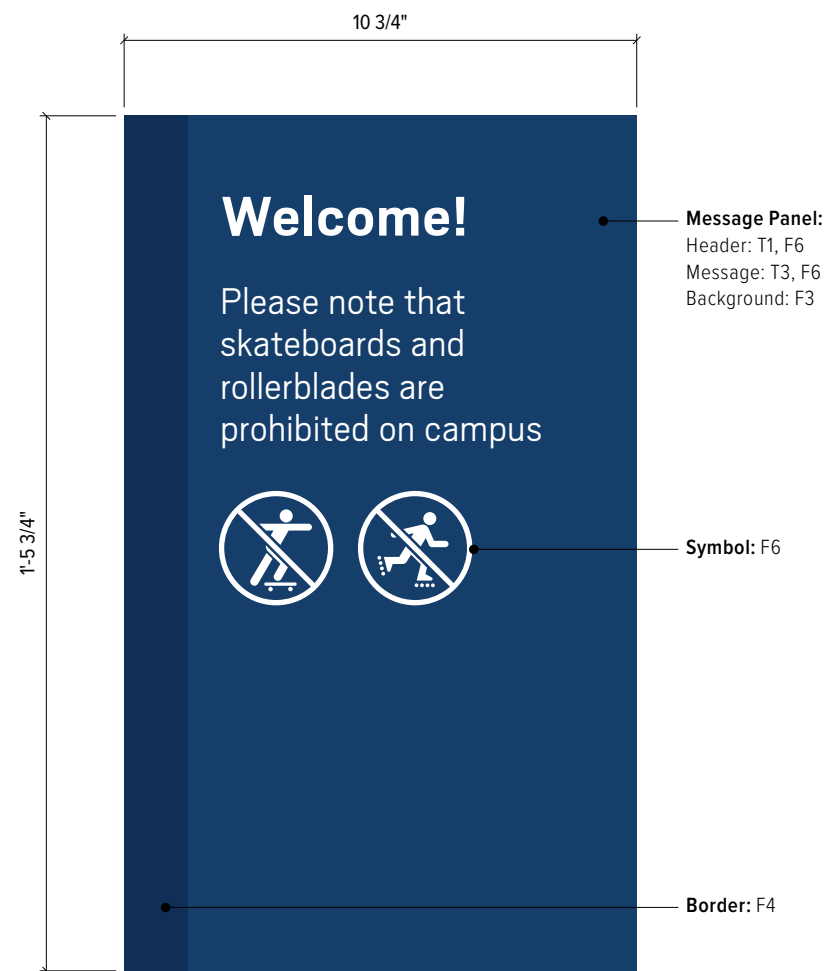

1 Elevation - Sign Type Q1
3" = 1'-0"

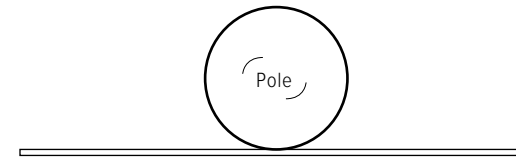

2 Plan - Sign Type Q1
3" = 1'-0"

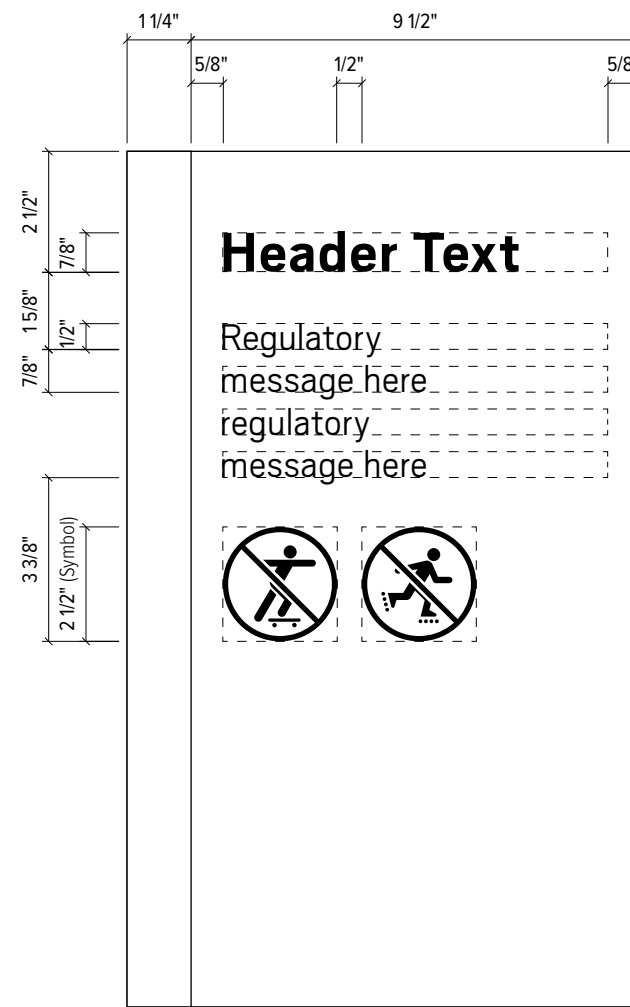

3 Graphic Layout - Sign Type Q1
3" = 1'-0"

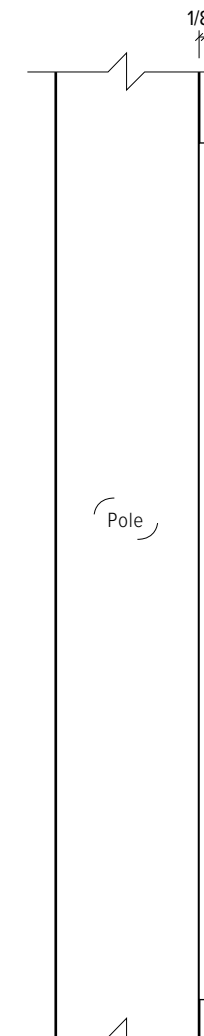

4 Side View - Sign Type Q1
3" = 1'-0"

TWO TWELVE

902 BROADWAY
FLOOR 20
NEW YORK, NY
10010/6002
212 254/6670 T
212 254/6614 F

For Planning & Coordination Only –
Not for Construction

This document and the entirety of its contents are property of 212/Harakawa Inc. and/or Two Twelve Associates, Inc. No part of this document shall be duplicated, disseminated, distributed or used for any purpose without express written permission.

Do not use for final construction. Sign fabricator to verify and be responsible for all dimensions and work conditions and inform this office of variations prior to performing work. Written dimensions govern over scaled dimensions.

No.	Revisions

Date 15 May 2017

Project No. UCONN-046

Phase CID

Project Title
University of Connecticut
Campus Wayfinding

Drawing Title

**Sign Type Q1
Regulatory, Pedestrian**

Drawing No.

CID.95

TWO TWELVE

902 BROADWAY
FLOOR 20
NEW YORK, NY
10010/6002
212 254/6670 T
212 254/6614 F

For Planning & Coordination Only –
Not for Construction

This document and the entirety of its contents are property of 212/Harakawa Inc. and/or Two Twelve Associates, Inc. No part of this document shall be duplicated, disseminated, distributed or used for any purpose without express written permission.

Do not use for final construction. Sign fabricator to verify and be responsible for all dimensions and work conditions and inform this office of variations prior to performing work. Written dimensions govern over scaled dimensions.

No.	Revisions
-----	-----------

Date	15 May 2017
------	-------------

Project No.	UCONN-046
-------------	-----------

Phase	CID
-------	-----

Project Title	University of Connecticut Campus Wayfinding
---------------	--

Drawing Title

**Sign Type Q1
Regulatory, Pedestrian**

Drawing No.

CID.96

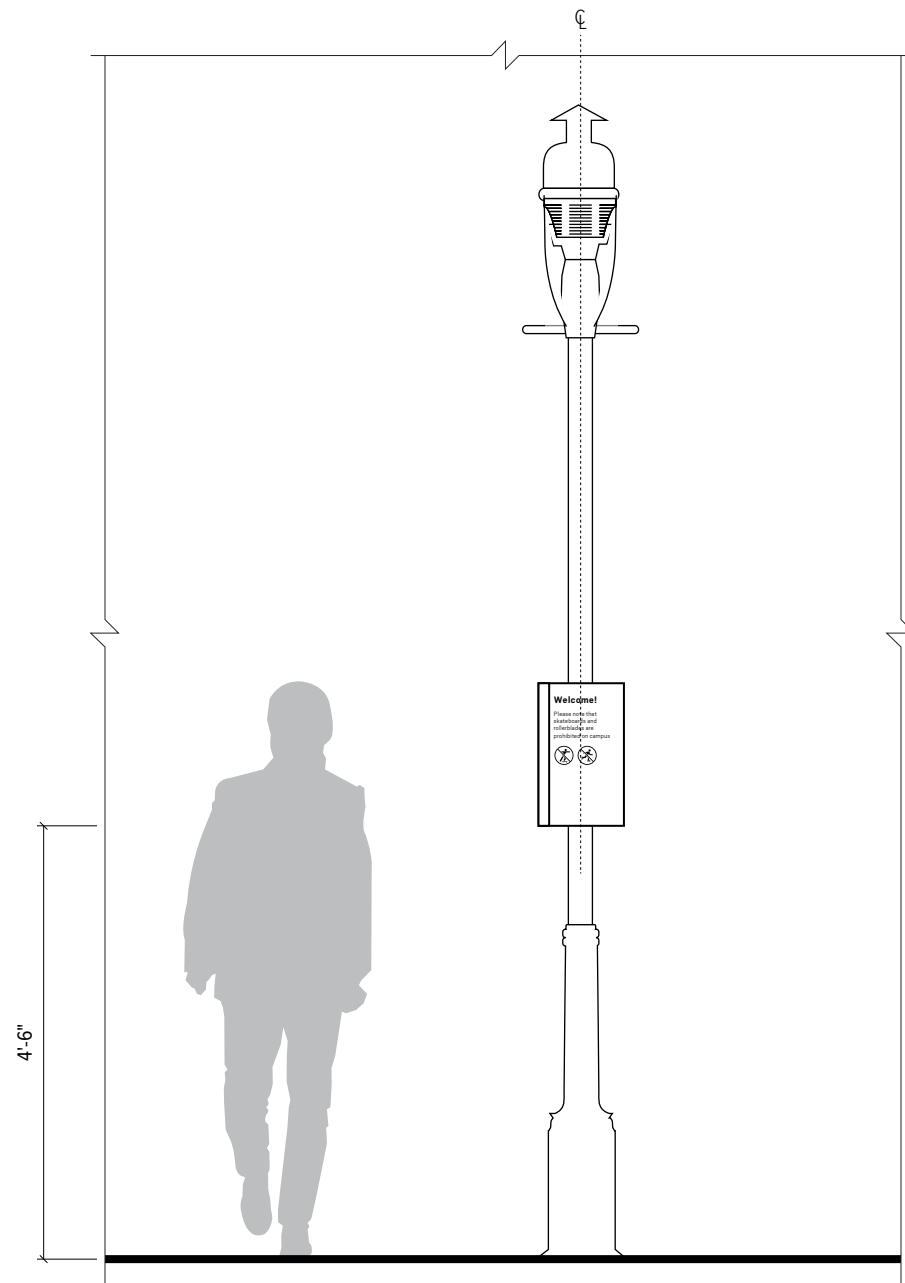

1 Installation Elevation - Sign Type Q1
1/2" = 1'-0"

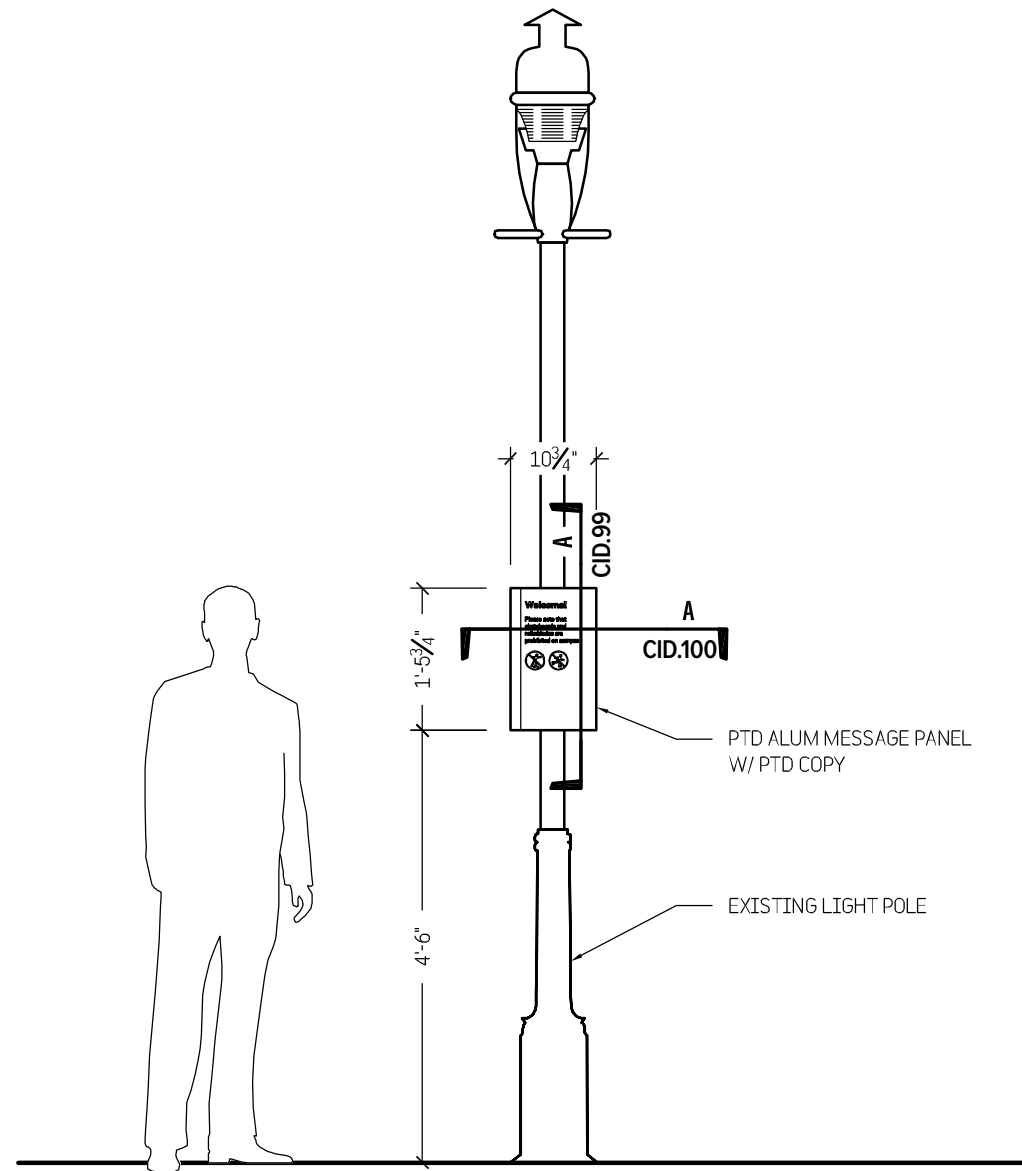

1 ELEVATION
3/4" = 1'-0"

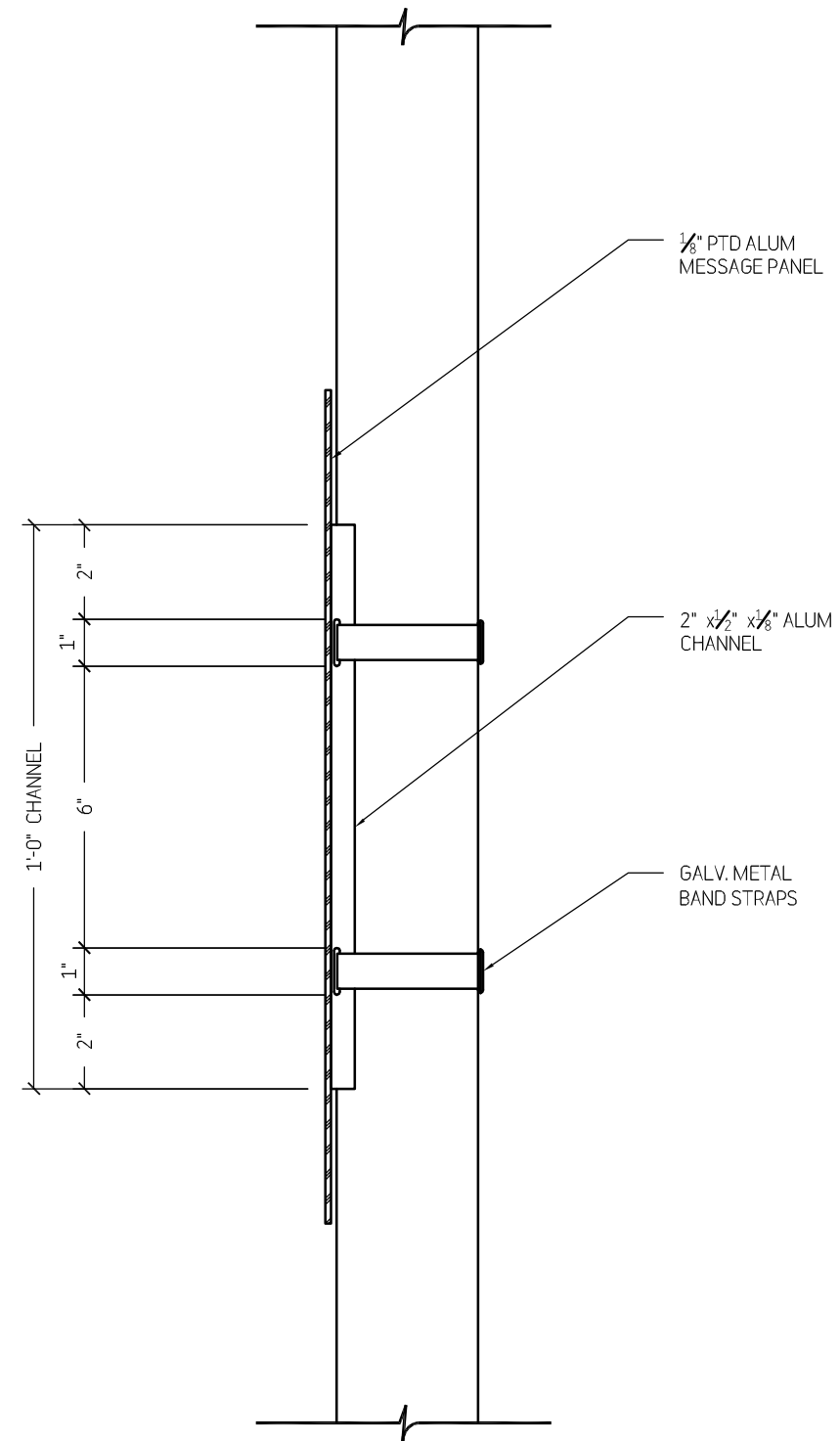

A SECTION
3" = 1'-0"

TWO TWELVE

902 BROADWAY
FLOOR 20
NEW YORK, NY
10010/6002
212 254/6670 T
212 254/6614 F

For Planning & Coordination Only –
Not for Construction

This document and the entirety of its contents are property of 212/Harakawa Inc. and/or Two Twelve Associates, Inc. No part of this document shall be duplicated, disseminated, distributed or used for any purpose without express written permission.

Do not use for final construction. Sign fabricator to verify and be responsible for all dimensions and work conditions and inform this office of variations prior to performing work. Written dimensions govern over scaled dimensions.

No.	Revisions

Date 15 May 2017

Project No. UCONN-046

Phase CID

Project Title
University of Connecticut
Campus Wayfinding

Sign Type Q1
Regulatory, Pedestrian

CID.97

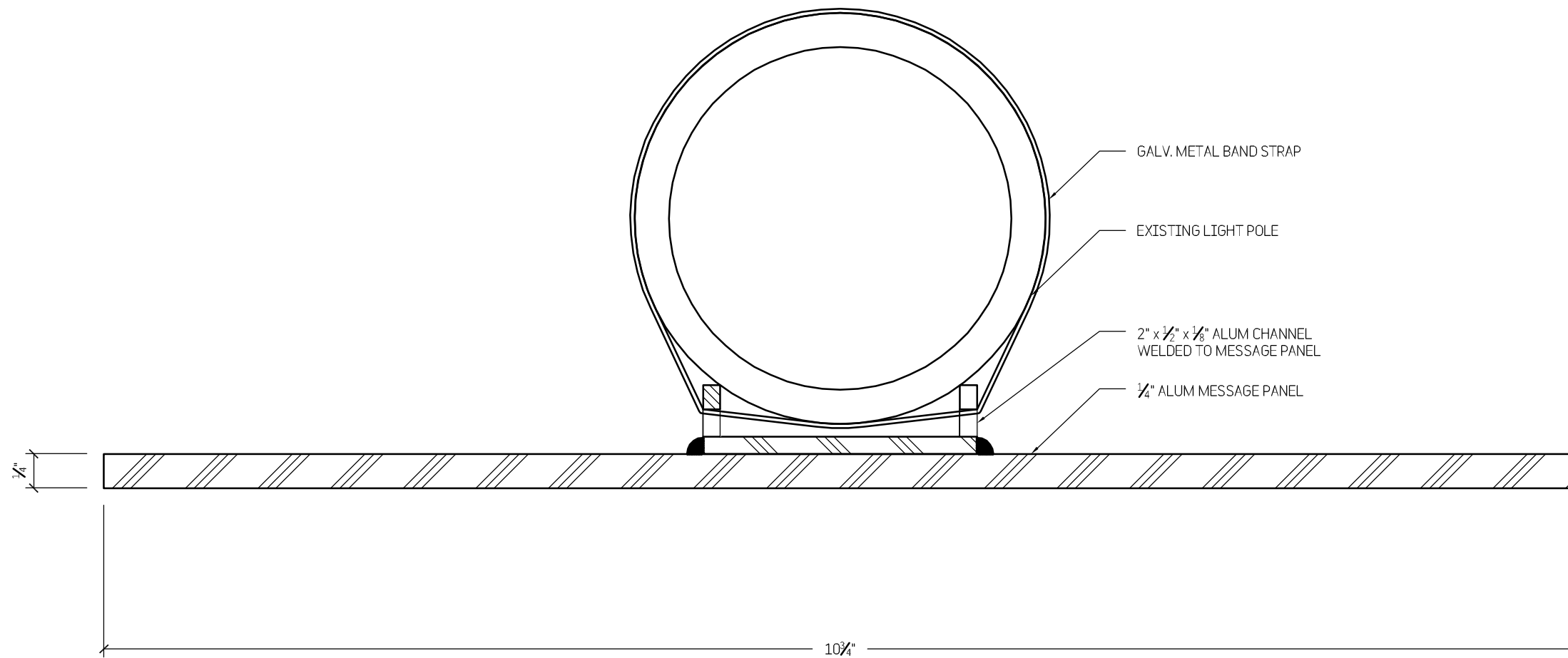

A SECTION
Half Size

TWO TWELVE

902 BROADWAY
FLOOR 20
NEW YORK, NY
10010/6002
212 254/6670 T
212 254/6614 F

For Planning & Coordination Only –
Not for Construction

This document and the entirety of its contents are property of 212/Harakawa Inc. and/or Two Twelve Associates, Inc. No part of this document shall be duplicated, disseminated, distributed or used for any purpose without express written permission.

Do not use for final construction. Sign fabricator to verify and be responsible for all dimensions and work conditions and inform this office of variations prior to performing work. Written dimensions govern over scaled dimensions.

No.	Revisions
-----	-----------

Date 15 May 2017

Project No. UCONN-046

Phase CID

Project Title

University of Connecticut
Campus Wayfinding

Sign Type Q1
Regulatory, Pedestrian

CID.98

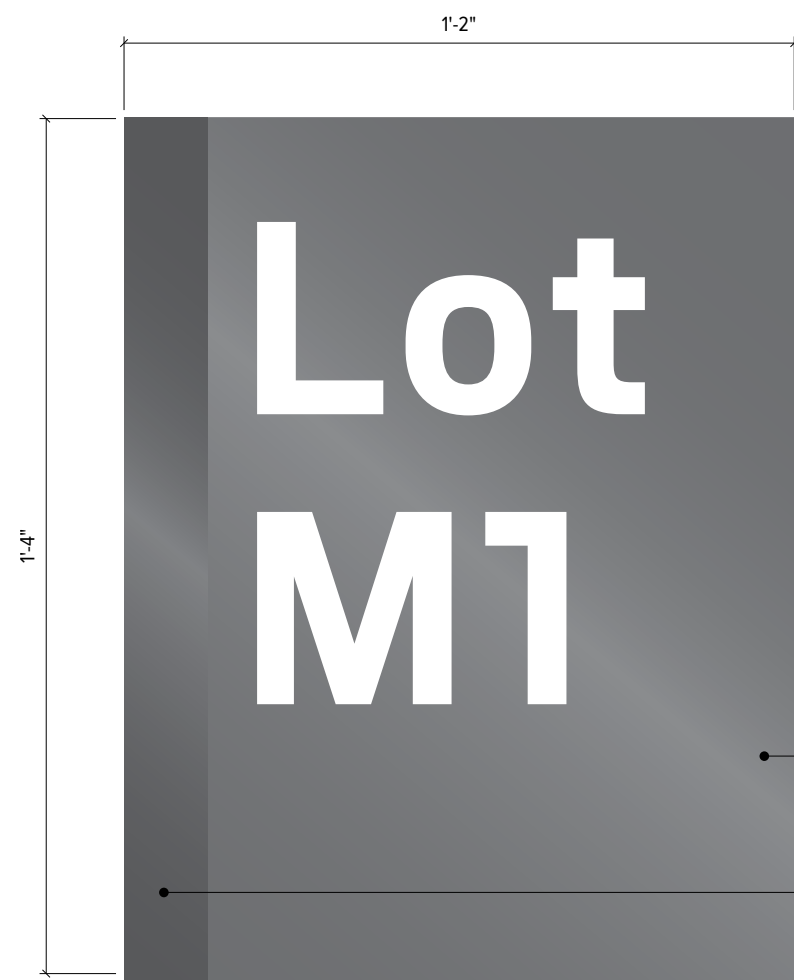

1 Elevation - Sign Type Q1a
3" = 1'-0"

Message Panel:
Lot Name: T1, F6
Background: F1

Border: F2

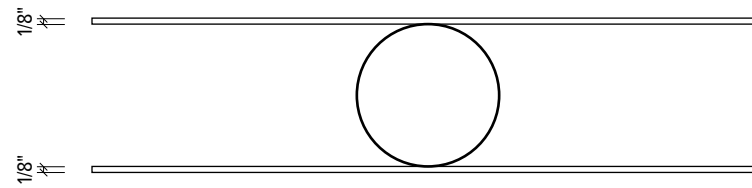

2 Plan - Sign Type Q1a
3" = 1'-0"

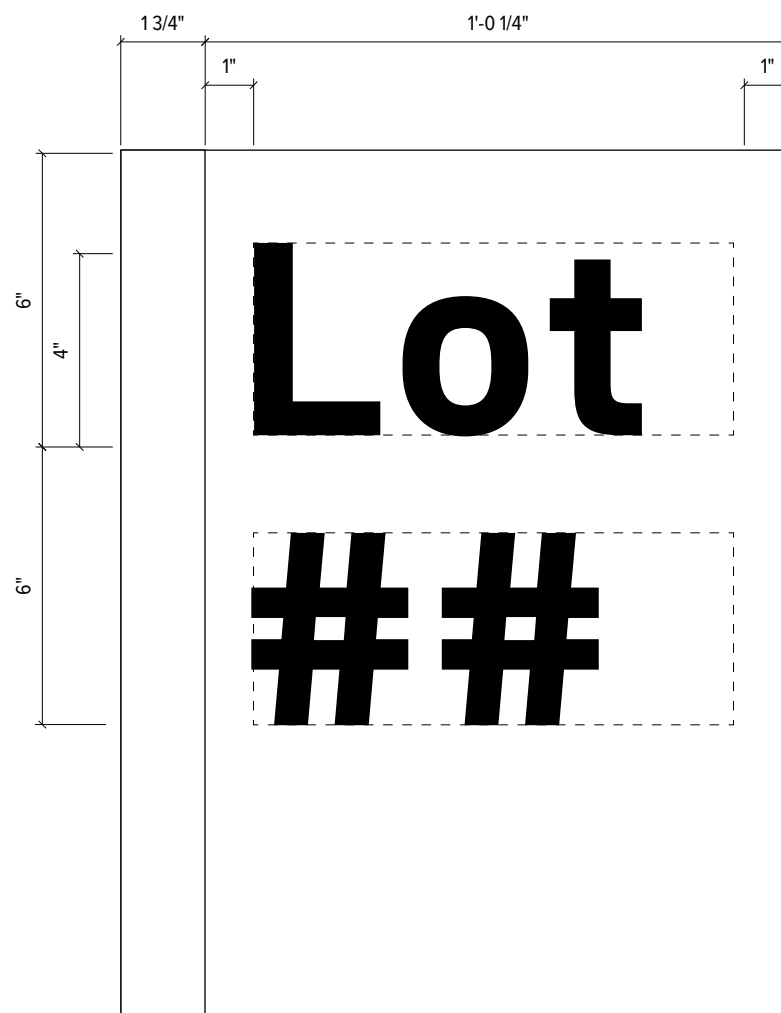

3 Graphic Layout - Sign Type Q1a
3" = 1'-0"

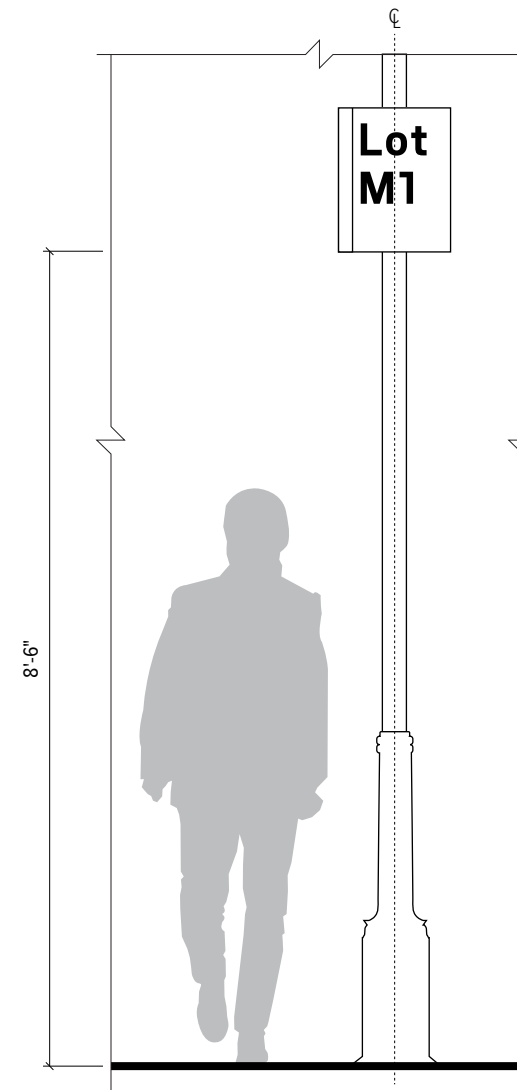

4 Installation Elevation - Sign Type Q1a
1/2" = 1'-0"

TWO TWELVE

902 BROADWAY
FLOOR 20
NEW YORK, NY
10010/6002
212 254/6670 T
212 254/6614 F

For Planning & Coordination Only –
Not for Construction

This document and the entirety of its
contents are property of 212/Harakawa
Inc. and/or Two Twelve Associates, Inc.
No part of this document shall be
duplicated, disseminated, distributed
or used for any purpose without
express written permission.

Do not use for final construction. Sign
fabricator to verify and be responsible
for all dimensions and work conditions
and inform this office of variations prior
to performing work. Written dimensions
govern over scaled dimensions.

No.	Revisions

Date 15 May 2017

Project No. UCONN-046

Phase CID

Project Title

University of Connecticut
Campus Wayfinding

Sign Type Q1a
Parking Lot ID,
Pole-Mount

CID.99

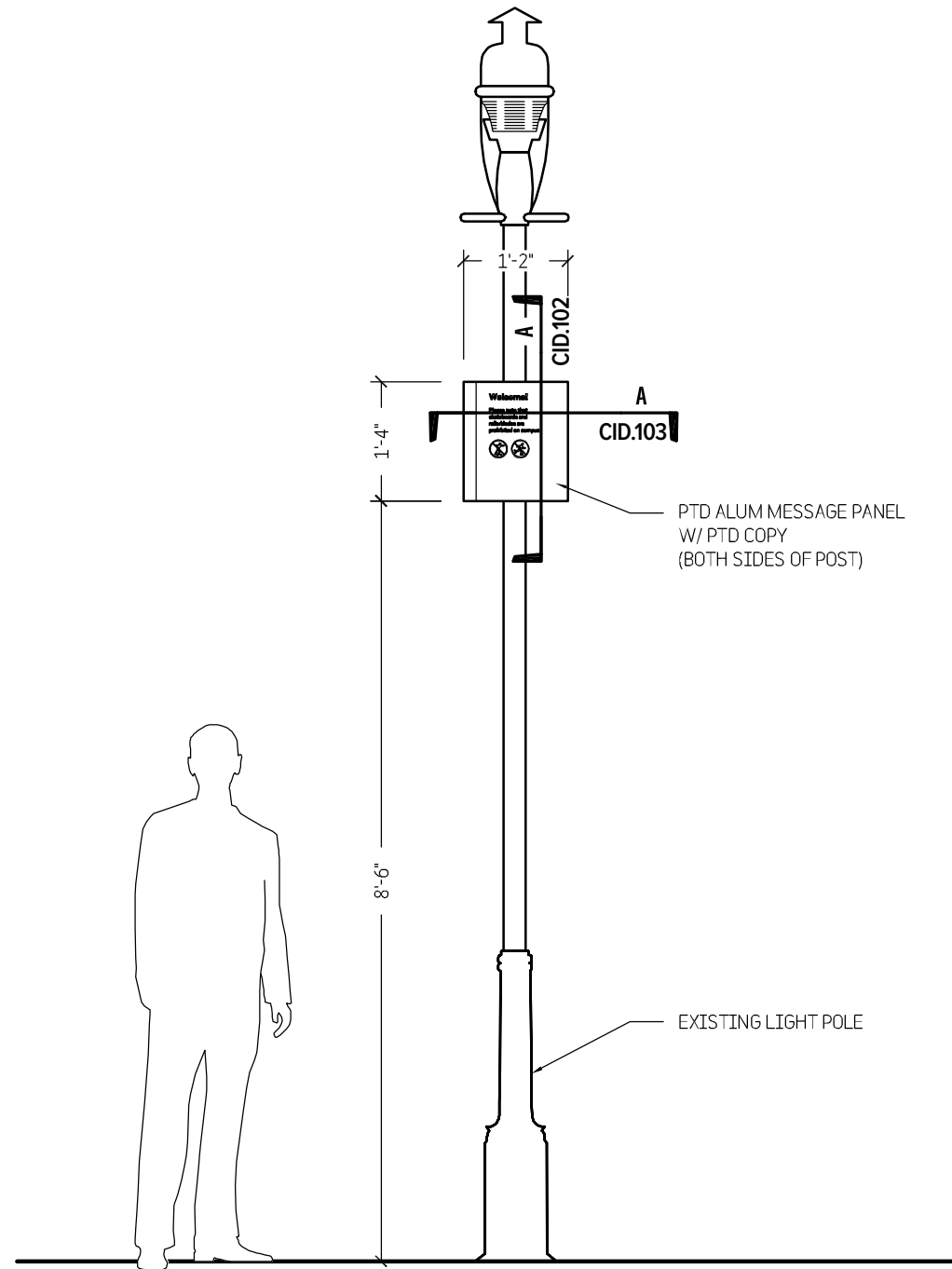

1 ELEVATION
3/4" = 1'-0"

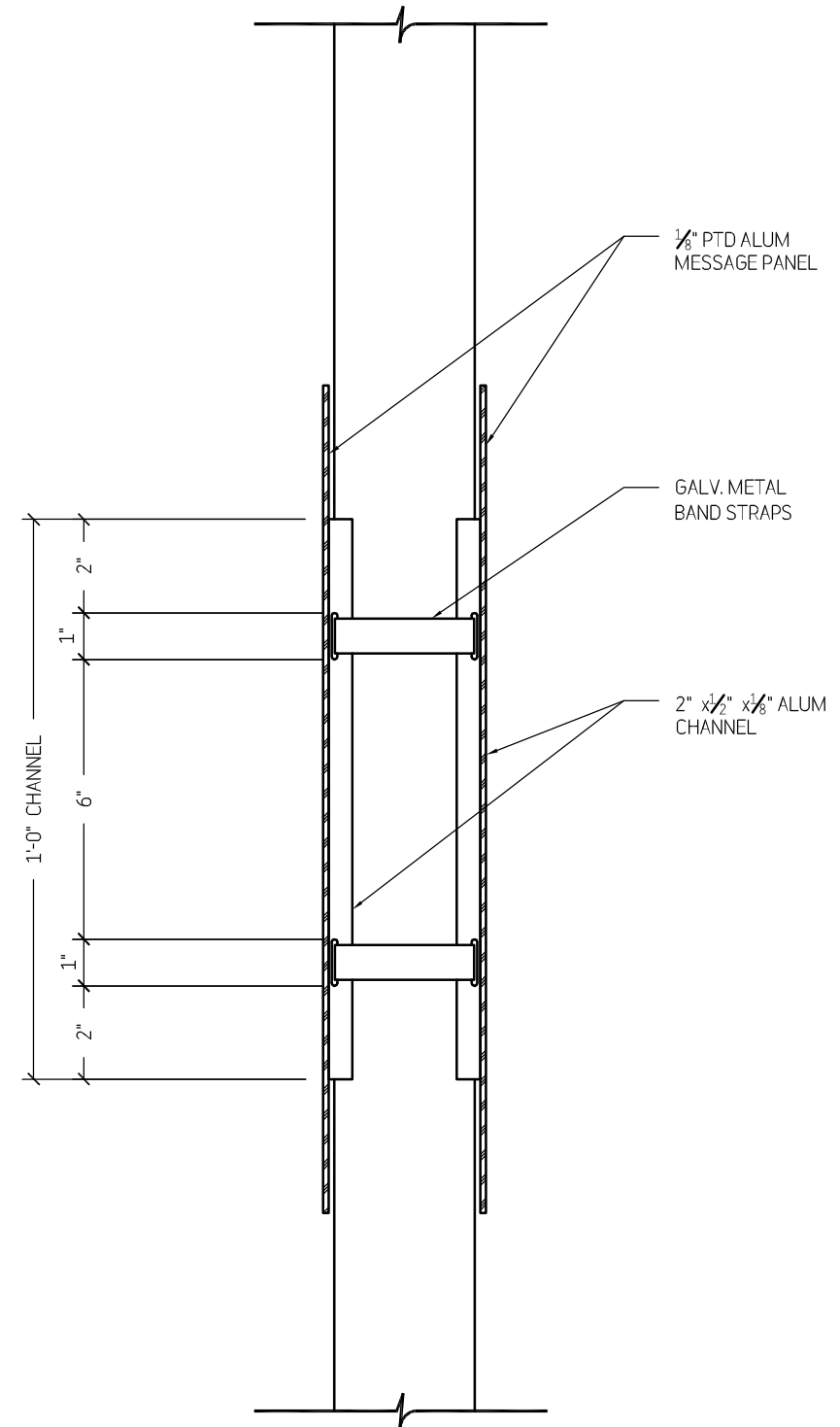

A SECTION
3" = 1'-0"

TWO TWELVE

902 BROADWAY
FLOOR 20
NEW YORK, NY
10010/6002
212 254/6670 T
212 254/6614 F

For Planning & Coordination Only –
Not for Construction

This document and the entirety of its contents are property of 212/Harakawa Inc. and/or Two Twelve Associates, Inc. No part of this document shall be duplicated, disseminated, distributed or used for any purpose without express written permission.

Do not use for final construction. Sign fabricator to verify and be responsible for all dimensions and work conditions and inform this office of variations prior to performing work. Written dimensions govern over scaled dimensions.

No.	Revisions

Date 15 May 2017

Project No. UCONN-046

Phase CID

Project Title
University of Connecticut
Campus Wayfinding

Sign Type Q1a
Parking Lot ID,
Pole-Mount

CID.100

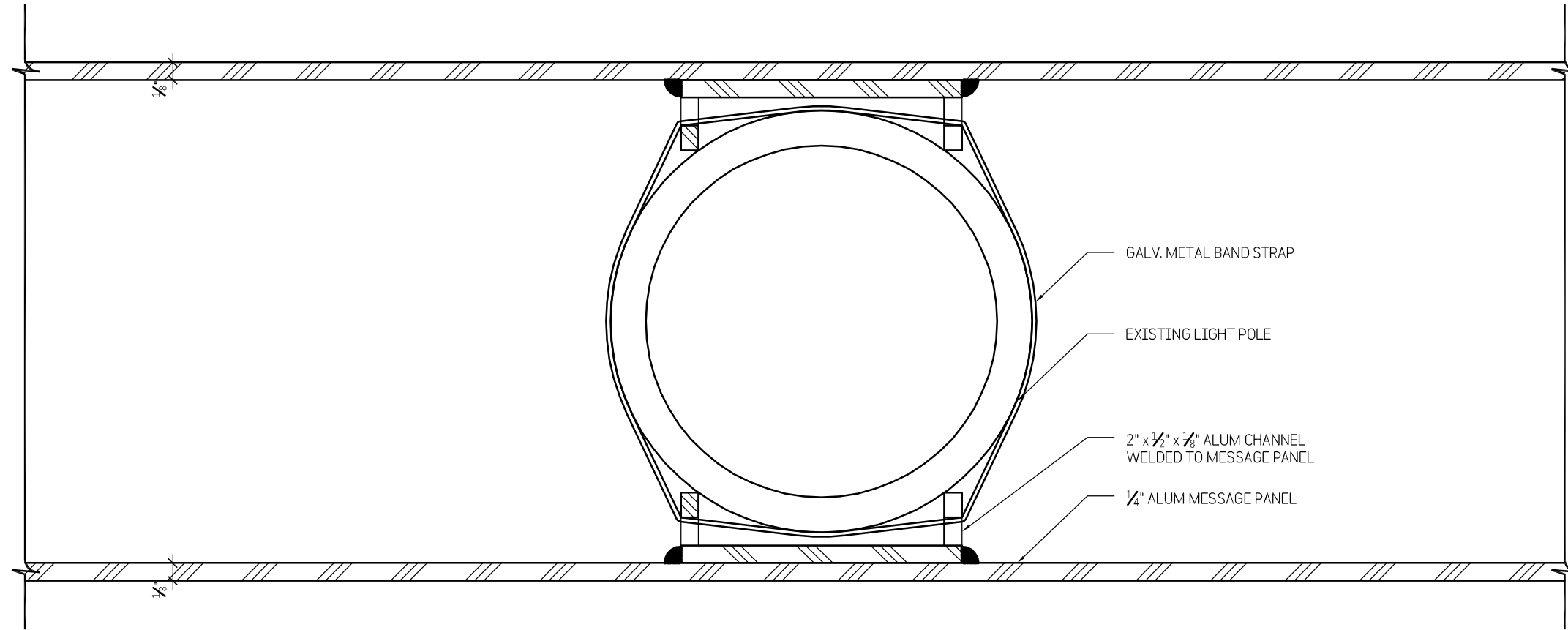

A SECTION
Half Size

TWO TWELVE

902 BROADWAY
FLOOR 20
NEW YORK, NY
10010/6002
212 254/6670 T
212 254/6614 F

For Planning & Coordination Only –
Not for Construction

This document and the entirety of its contents are property of 212/Harakawa Inc. and/or Two Twelve Associates, Inc. No part of this document shall be duplicated, disseminated, distributed or used for any purpose without express written permission.

Do not use for final construction. Sign fabricator to verify and be responsible for all dimensions and work conditions and inform this office of variations prior to performing work. Written dimensions govern over scaled dimensions.

No.	Revisions
-----	-----------

Date 15 May 2017

Project No. UCONN-046

Phase CID

Project Title
University of Connecticut
Campus Wayfinding

**Sign Type Q1a
Parking Lot ID,
Pole-Mount**

CID.101

TWO TWELVE

902 BROADWAY
 FLOOR 20
 NEW YORK, NY
 10010/6002
 212 254/6670 T
 212 254/6614 F

For Planning & Coordination Only –
 Not for Construction

This document and the entirety of its contents are property of 212/Harakawa Inc. and/or Two Twelve Associates, Inc. No part of this document shall be duplicated, disseminated, distributed or used for any purpose without express written permission.

Do not use for final construction. Sign fabricator to verify and be responsible for all dimensions and work conditions and inform this office of variations prior to performing work. Written dimensions govern over scaled dimensions.

No.	Revisions

Date	15 May 2017
Project No.	UCONN-046
Phase	CID
Project Title	University of Connecticut Campus Wayfinding

Sign Type Q2
Regulatory, Pedestrian,
Fence Mounted

CID.102

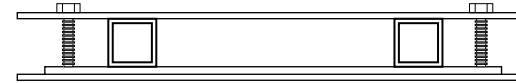

2 Plan - Sign Type Q2
 3" = 1'-0"

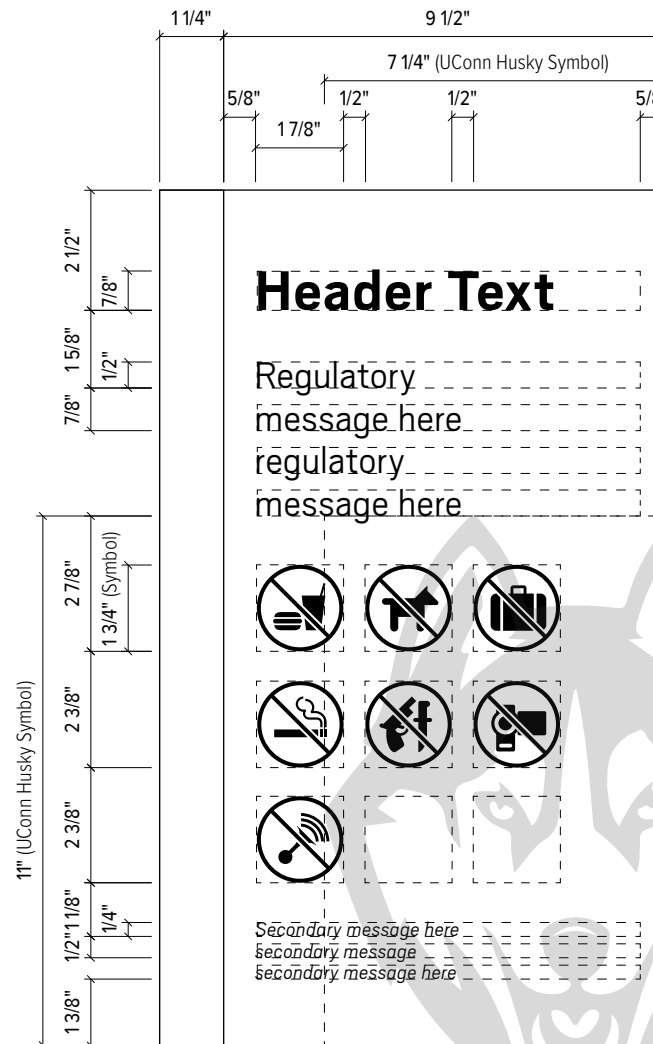

3 Graphic Layout - Sign Type Q2
 3" = 1'-0"

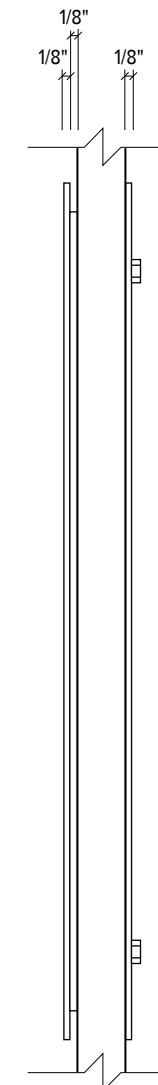

4 Side View - Sign Type Q2
 3" = 1'-0"

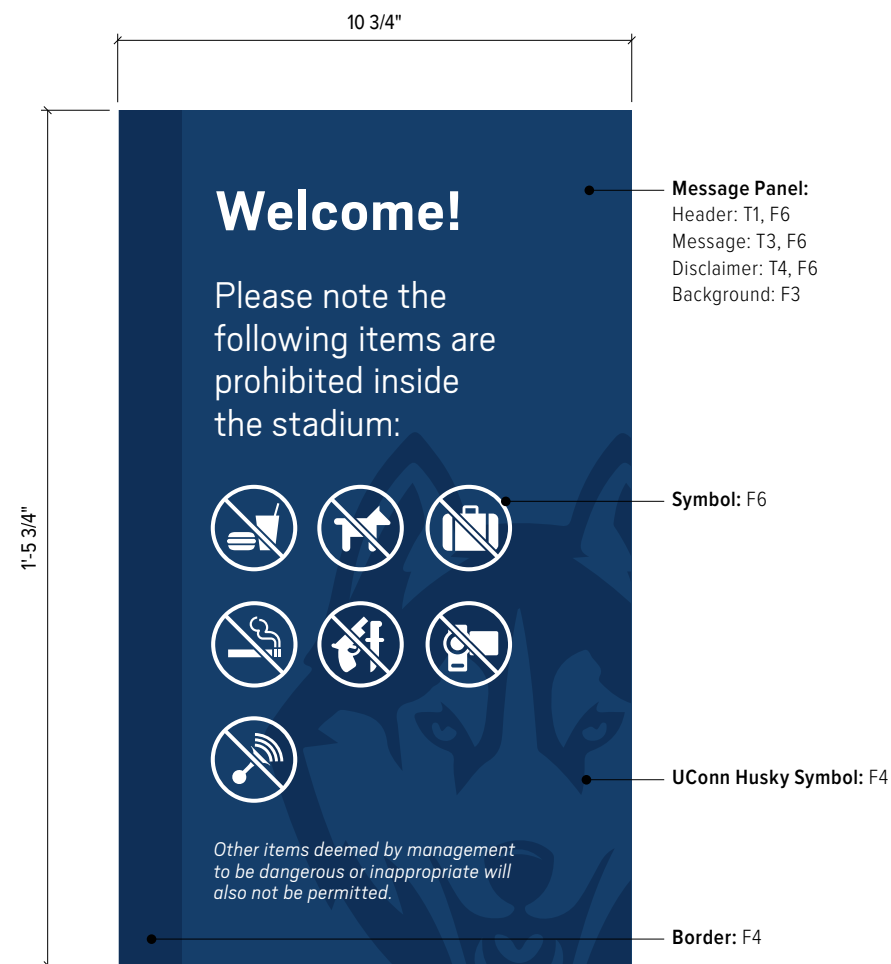

1 Elevation - Sign Type Q2
 3" = 1'-0"

TWO TWELVE

902 BROADWAY
FLOOR 20
NEW YORK, NY
10010/6002
212 254/6670 T
212 254/6614 F

For Planning & Coordination Only –
Not for Construction

This document and the entirety of its contents are property of 212/Harakawa Inc. and/or Two Twelve Associates, Inc. No part of this document shall be duplicated, disseminated, distributed or used for any purpose without express written permission.

Do not use for final construction. Sign fabricator to verify and be responsible for all dimensions and work conditions and inform this office of variations prior to performing work. Written dimensions govern over scaled dimensions.

No. Revisions

Date 15 May 2017

Project No. UCONN-046

Phase CID

Project Title
University of Connecticut
Campus Wayfinding

**Sign Type Q2
Regulatory, Pedestrian,
Fence Mounted**

CID.103



1 Installation Elevation - Sign Type Q2
3/4" = 1'-0"

TWO TWELVE

902 BROADWAY
 FLOOR 20
 NEW YORK, NY
 10010/6002
 212 254/6670 T
 212 254/6614 F

For Planning & Coordination Only –
 Not for Construction

This document and the entirety of its contents are property of 212/Harakawa Inc. and/or Two Twelve Associates, Inc. No part of this document shall be duplicated, disseminated, distributed or used for any purpose without express written permission.

Do not use for final construction. Sign fabricator to verify and be responsible for all dimensions and work conditions and inform this office of variations prior to performing work. Written dimensions govern over scaled dimensions.

No.	Revisions

Date 15 May 2017

Project No. UCONN-046

Phase CID

Project Title
 University of Connecticut
 Campus Wayfinding

Sign Type Q2
Regulatory, Pedestrian,
Fence Mounted

CID.104

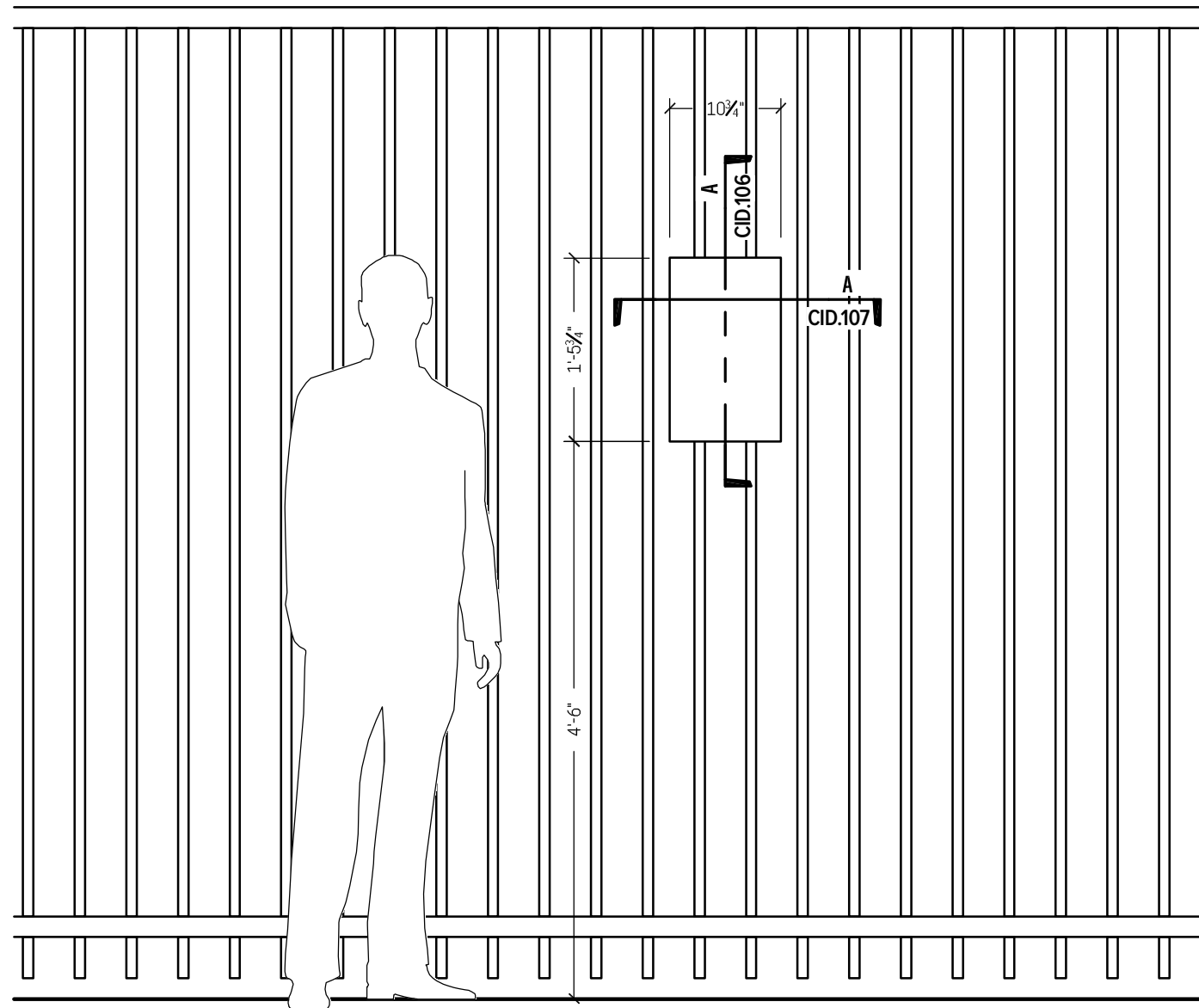

1 ELEVATION
 3/4" = 1'-0"

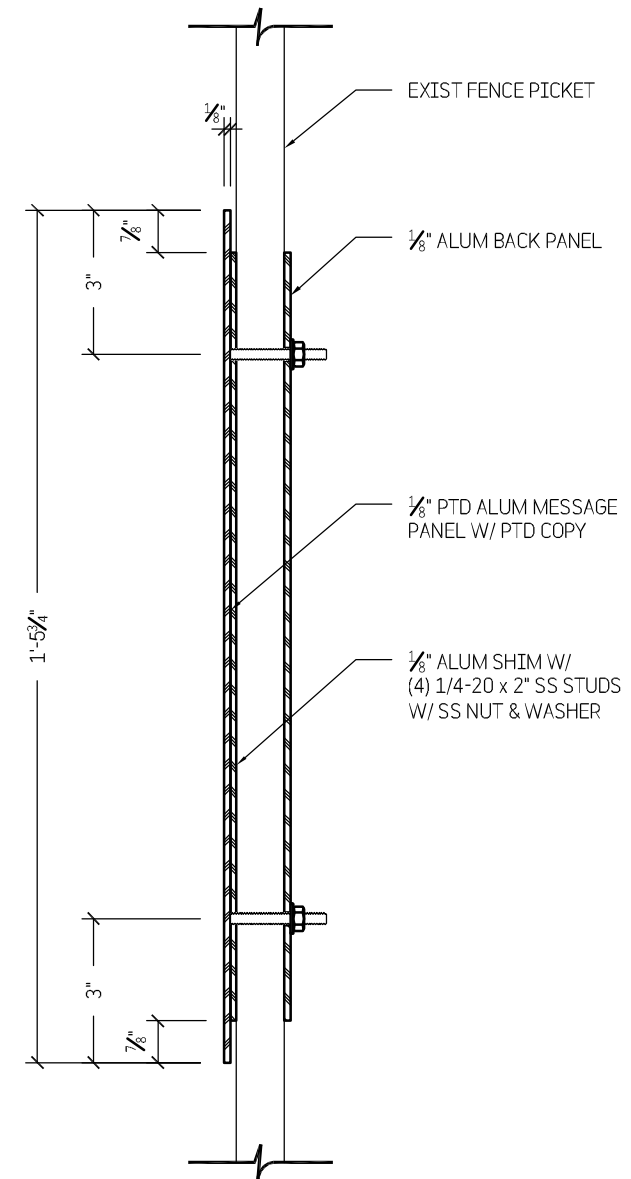

A SECTION
 3" = 1'-0"

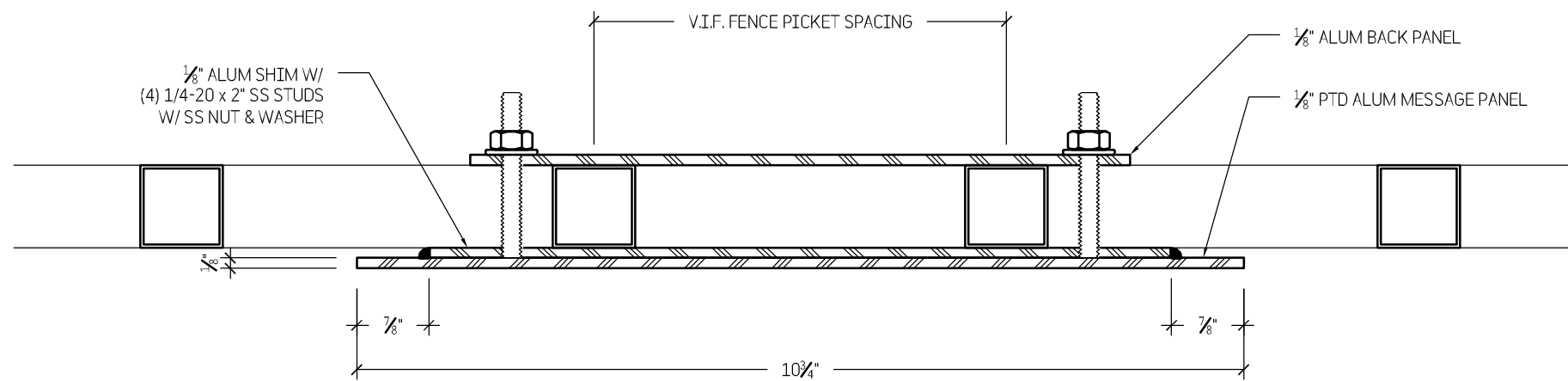

A SECTION
Half Size

TWO TWELVE

902 BROADWAY
FLOOR 20
NEW YORK, NY
10010/6002
212 254/6670 T
212 254/6614 F

For Planning & Coordination Only –
Not for Construction

This document and the entirety of its contents are property of 212/Harakawa Inc. and/or Two Twelve Associates, Inc. No part of this document shall be duplicated, disseminated, distributed or used for any purpose without express written permission.

Do not use for final construction. Sign fabricator to verify and be responsible for all dimensions and work conditions and inform this office of variations prior to performing work. Written dimensions govern over scaled dimensions.

No.	Revisions
-----	-----------

Date 15 May 2017

Project No. UCONN-046

Phase CID

Project Title

University of Connecticut
Campus Wayfinding

**Sign Type Q2
Regulatory, Pedestrian,
Fence Mounted**

CID.105

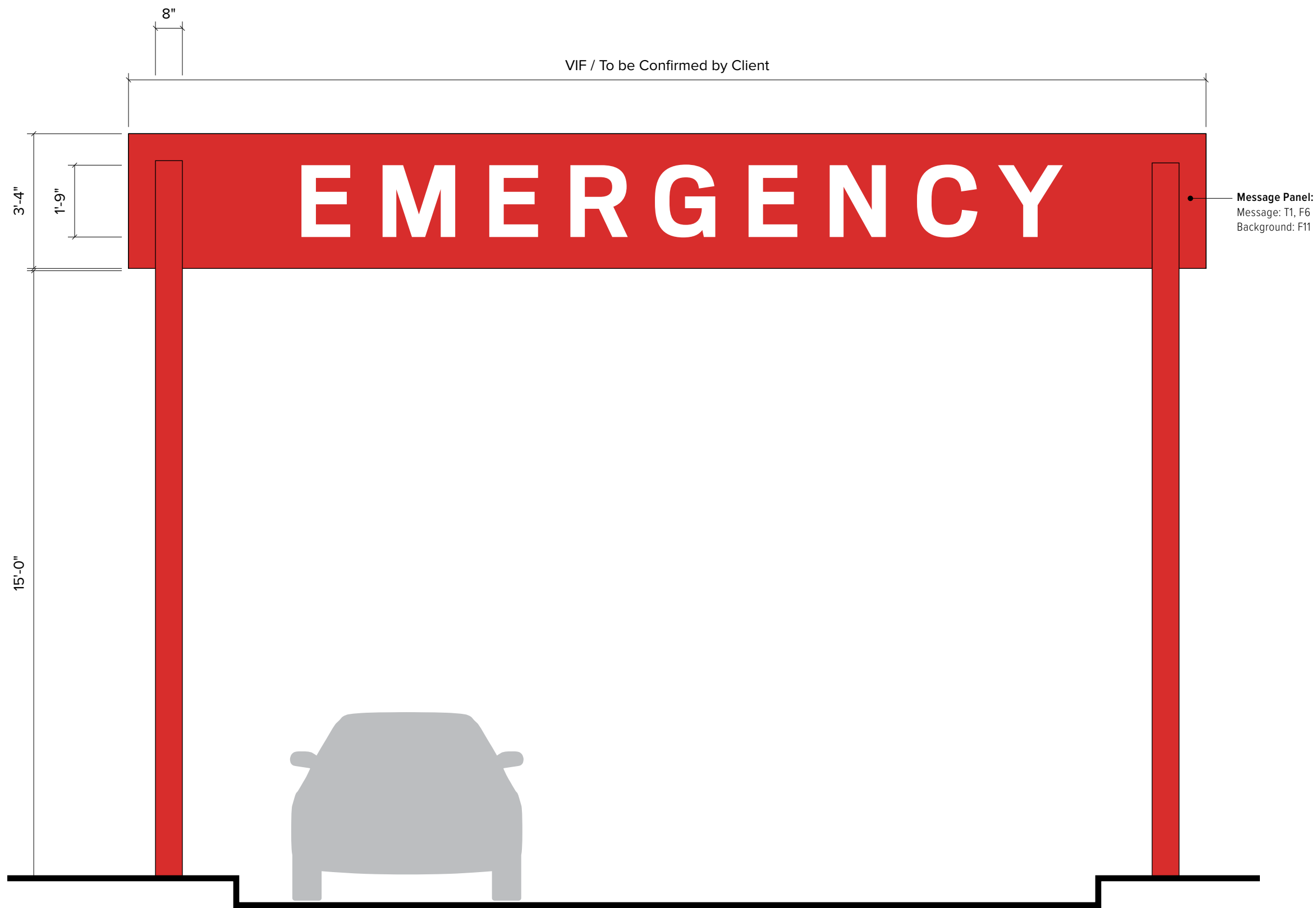

TWO TWELVE

902 BROADWAY
FLOOR 20
NEW YORK, NY
10010/6002
212 254/6670 T
212 254/6614 F

For Planning & Coordination Only –
Not for Construction

This document and the entirety of its contents are property of 212/Harakawa Inc. and/or Two Twelve Associates, Inc. No part of this document shall be duplicated, disseminated, distributed or used for any purpose without express written permission.

Do not use for final construction. Sign fabricator to verify and be responsible for all dimensions and work conditions and inform this office of variations prior to performing work. Written dimensions govern over scaled dimensions.

No.	Revisions
-----	-----------

Date 15 May 2017

Project No. UCONN-046

Phase CID

Project Title
University of Connecticut
Campus Wayfinding

Sign Type R
Emergency ID

CID.106

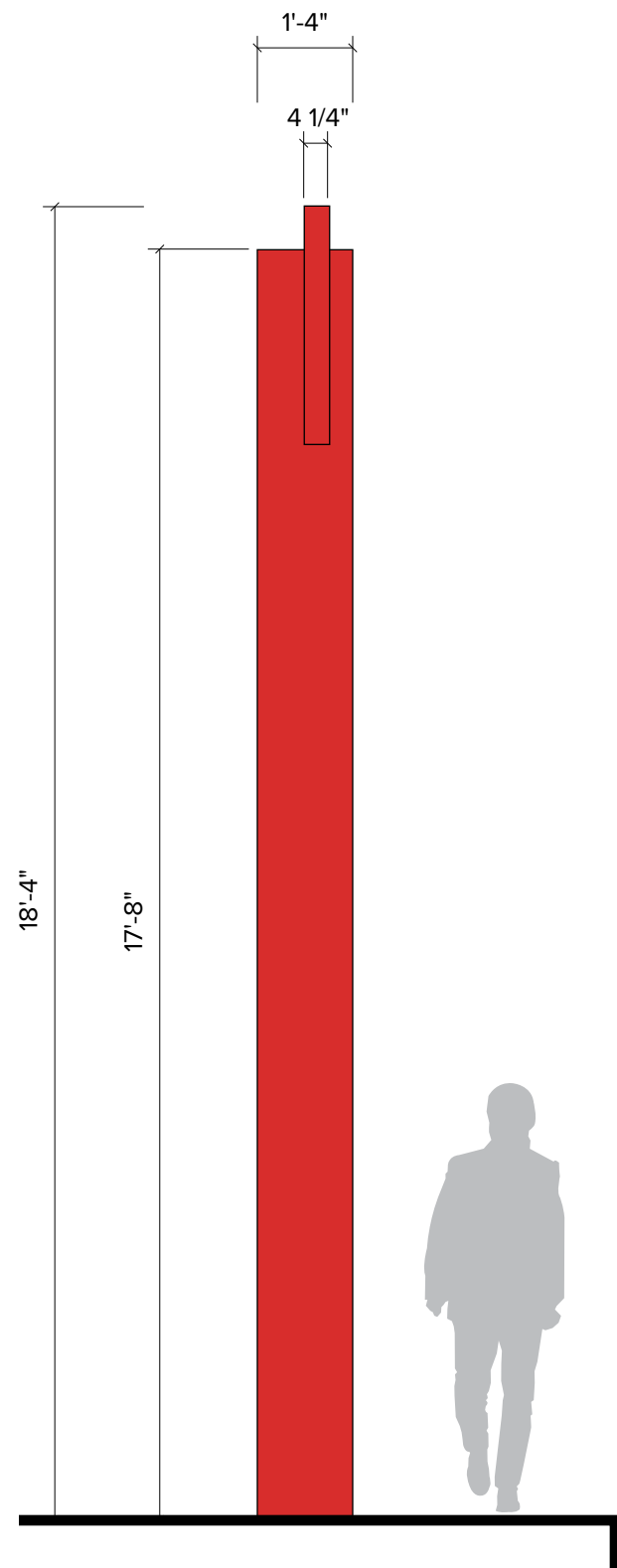

1 Elevation - Sign Type R
 3/8" = 1'-0"

TWO TWELVE

902 BROADWAY
 FLOOR 20
 NEW YORK, NY
 10010/6002
 212 254/6670 T
 212 254/6614 F

For Planning & Coordination Only –
 Not for Construction

This document and the entirety of its contents are property of 212/Harakawa Inc. and/or Two Twelve Associates, Inc. No part of this document shall be duplicated, disseminated, distributed or used for any purpose without express written permission.

Do not use for final construction. Sign fabricator to verify and be responsible for all dimensions and work conditions and inform this office of variations prior to performing work. Written dimensions govern over scaled dimensions.

No.	Revisions
-----	-----------

Date 15 May 2017

Project No. UCONN-046

Phase CID

Project Title

University of Connecticut
 Campus Wayfinding

Sign Type R
Emergency ID

CID.107

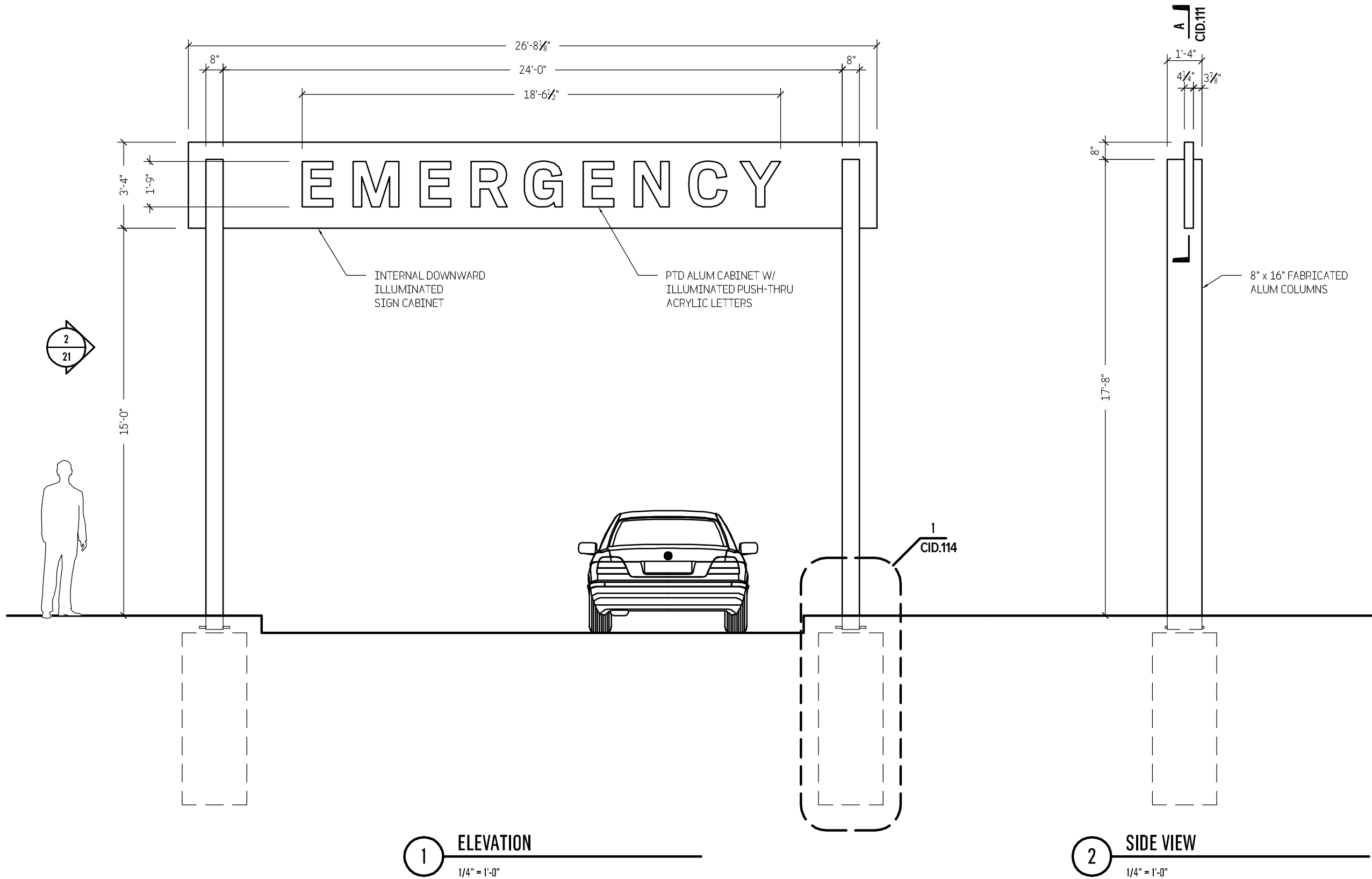

TWO TWELVE

902 BROADWAY
 FLOOR 20
 NEW YORK, NY
 10010/6002
 212 254/6670 T
 212 254/6614 F

For Planning & Coordination Only –
 Not for Construction

This document and the entirety of its contents are property of 212/Harakawa Inc. and/or Two Twelve Associates, Inc. No part of this document shall be duplicated, disseminated, distributed or used for any purpose without express written permission.

Do not use for final construction. Sign fabricator to verify and be responsible for all dimensions and work conditions and inform this office of variations prior to performing work. Written dimensions govern over scaled dimensions.

No.	Revisions

Date 15 May 2017

Project No. UCONN-046

Phase CID

Project Title
 University of Connecticut
 Campus Wayfinding

Sign Type R
Emergency ID

CID.108

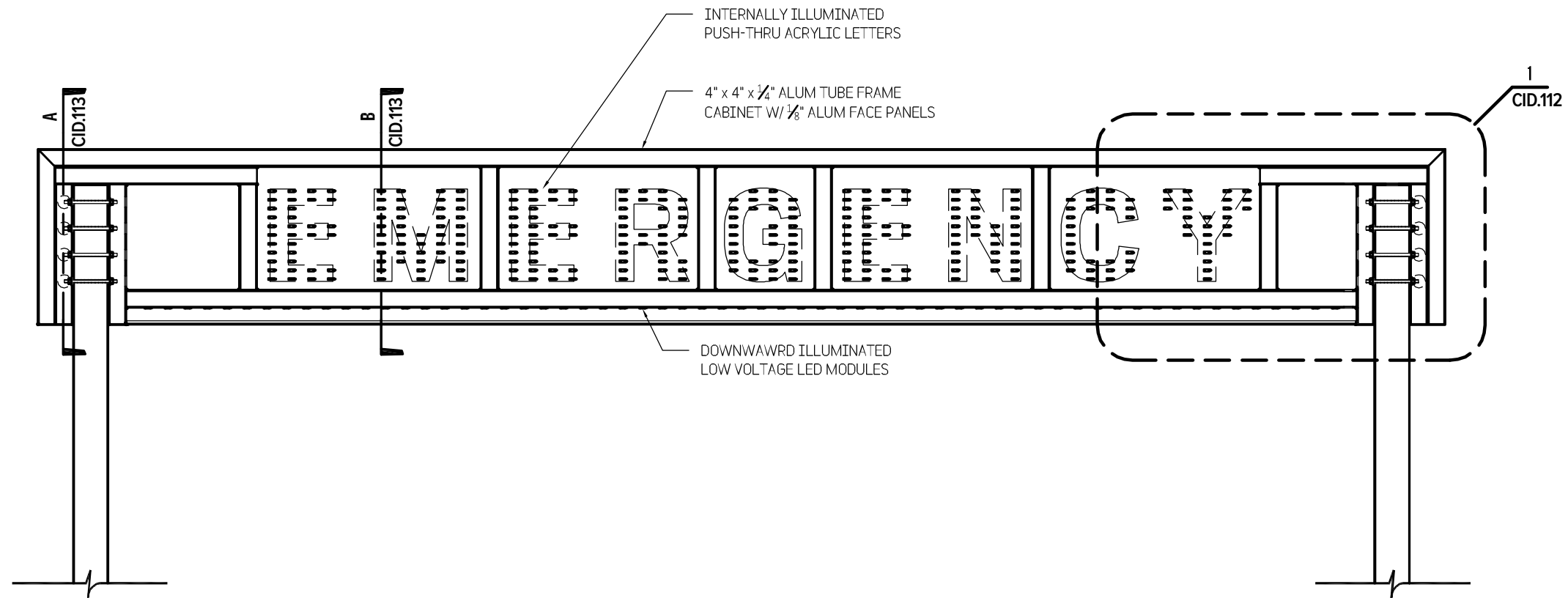

A SECTION
3/8" = 1'-0"

TWO TWELVE

902 BROADWAY
FLOOR 20
NEW YORK, NY
10010/6002
212 254/6670 T
212 254/6614 F

For Planning & Coordination Only –
Not for Construction

This document and the entirety of its
contents are property of 212/Harakawa
Inc. and/or Two Twelve Associates, Inc.
No part of this document shall be
duplicated, disseminated, distributed
or used for any purpose without
express written permission.

Do not use for final construction. Sign
fabricator to verify and be responsible
for all dimensions and work conditions
and inform this office of variations prior
to performing work. Written dimensions
govern over scaled dimensions.

No.	Revisions
-----	-----------

Date 15 May 2017

Project No. UCONN-046

Phase CID

Project Title
University of Connecticut
Campus Wayfinding

Sign Type R
Emergency ID

CID.109

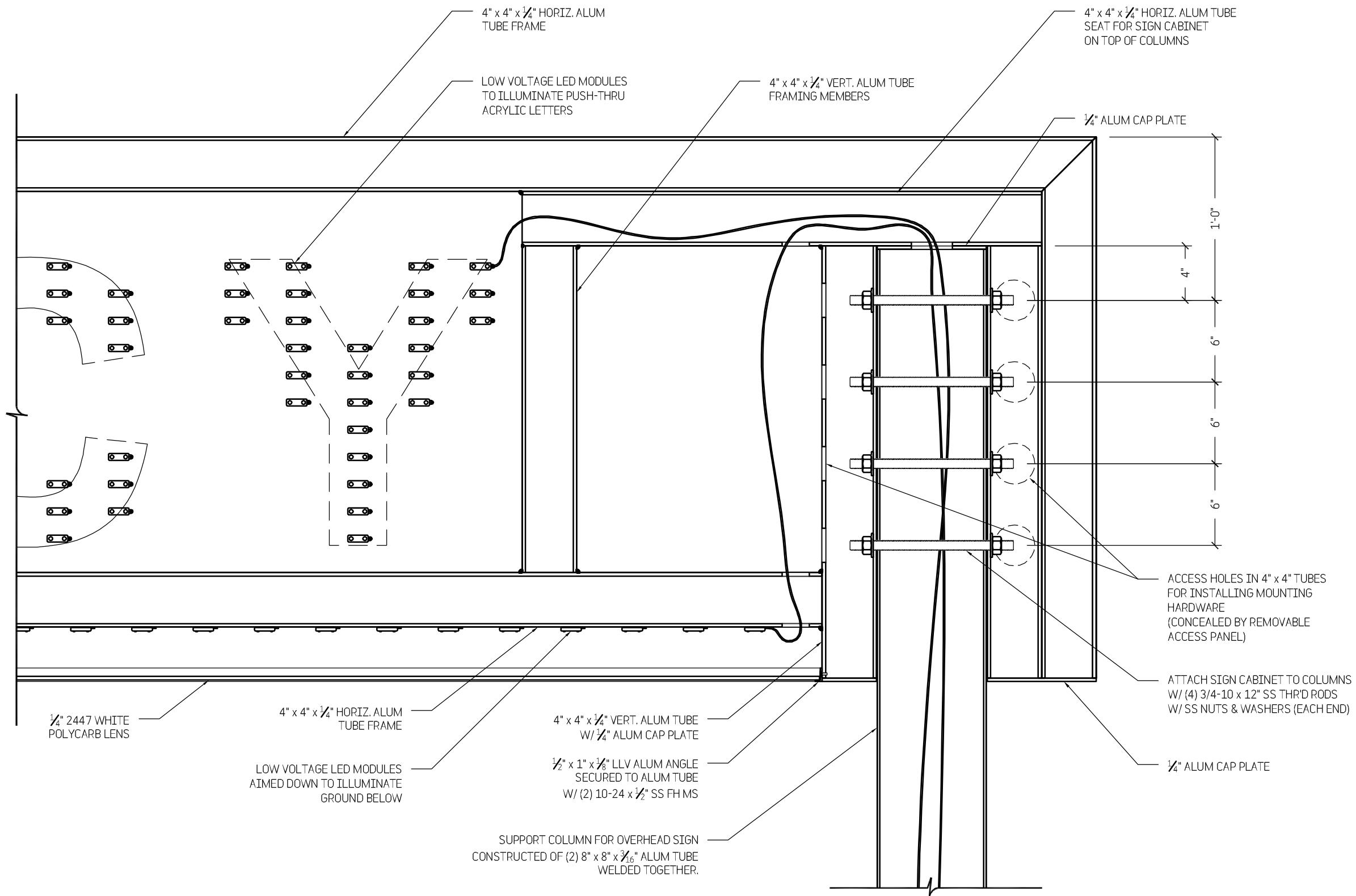

TWO TWELVE

902 BROADWAY
FLOOR 20
NEW YORK, NY
10010/6002
212 254/6670 T
212 254/6614 F

For Planning & Coordination Only –
Not for Construction

This document and the entirety of its contents are property of 212/Harakawa Inc. and/or Two Twelve Associates, Inc. No part of this document shall be duplicated, disseminated, distributed or used for any purpose without express written permission.

Do not use for final construction. Sign fabricator to verify and be responsible for all dimensions and work conditions and inform this office of variations prior to performing work. Written dimensions govern over scaled dimensions.

No.	Revisions

Date 15 May 2017

Project No. UCONN-046

Phase CID

Project Title

University of Connecticut
Campus Wayfinding

Sign Type R
Emergency ID

CID.110

1 DETAIL
1 1/2" = 1'-0"

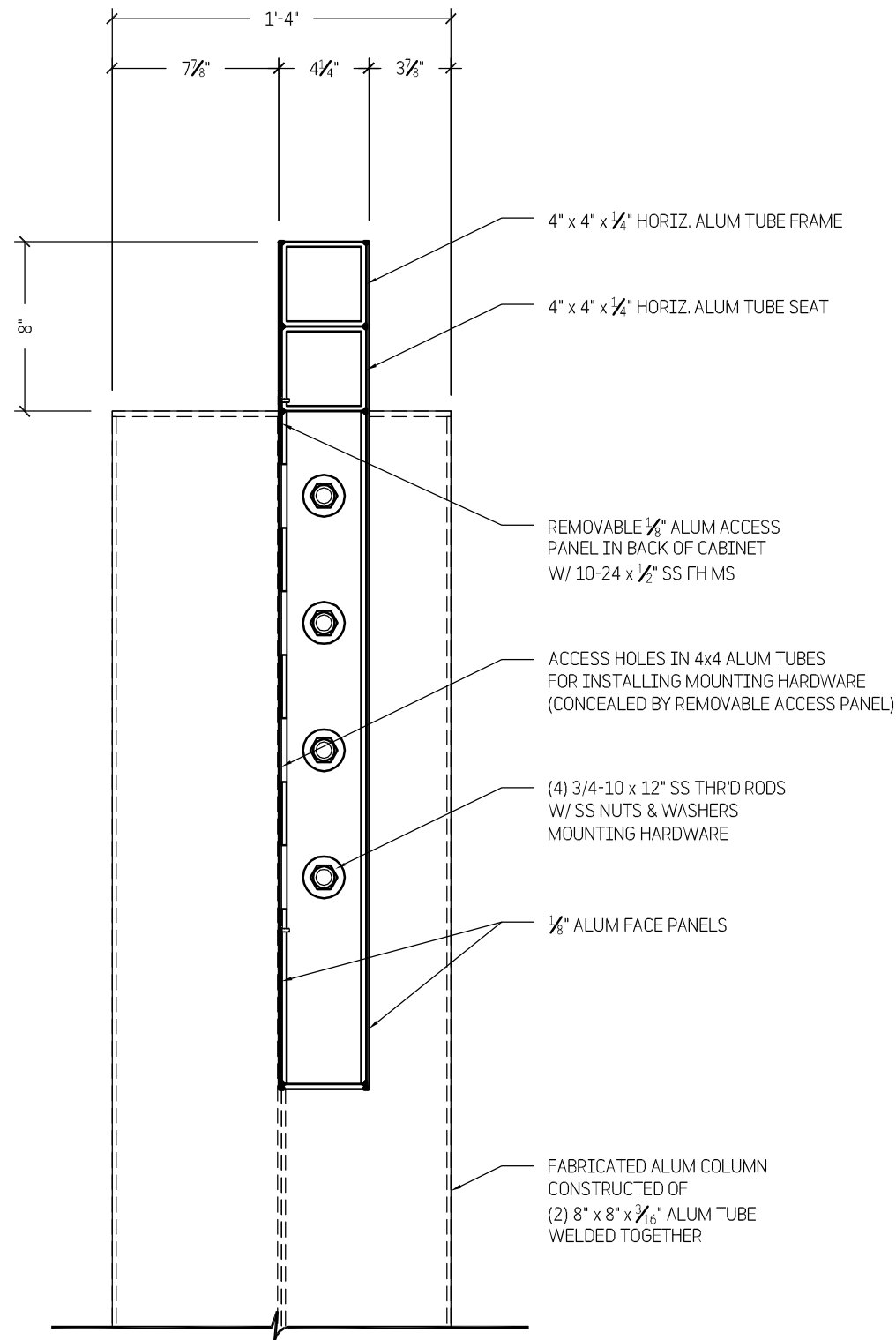

A SECTION
1 1/2" - 1'-0"

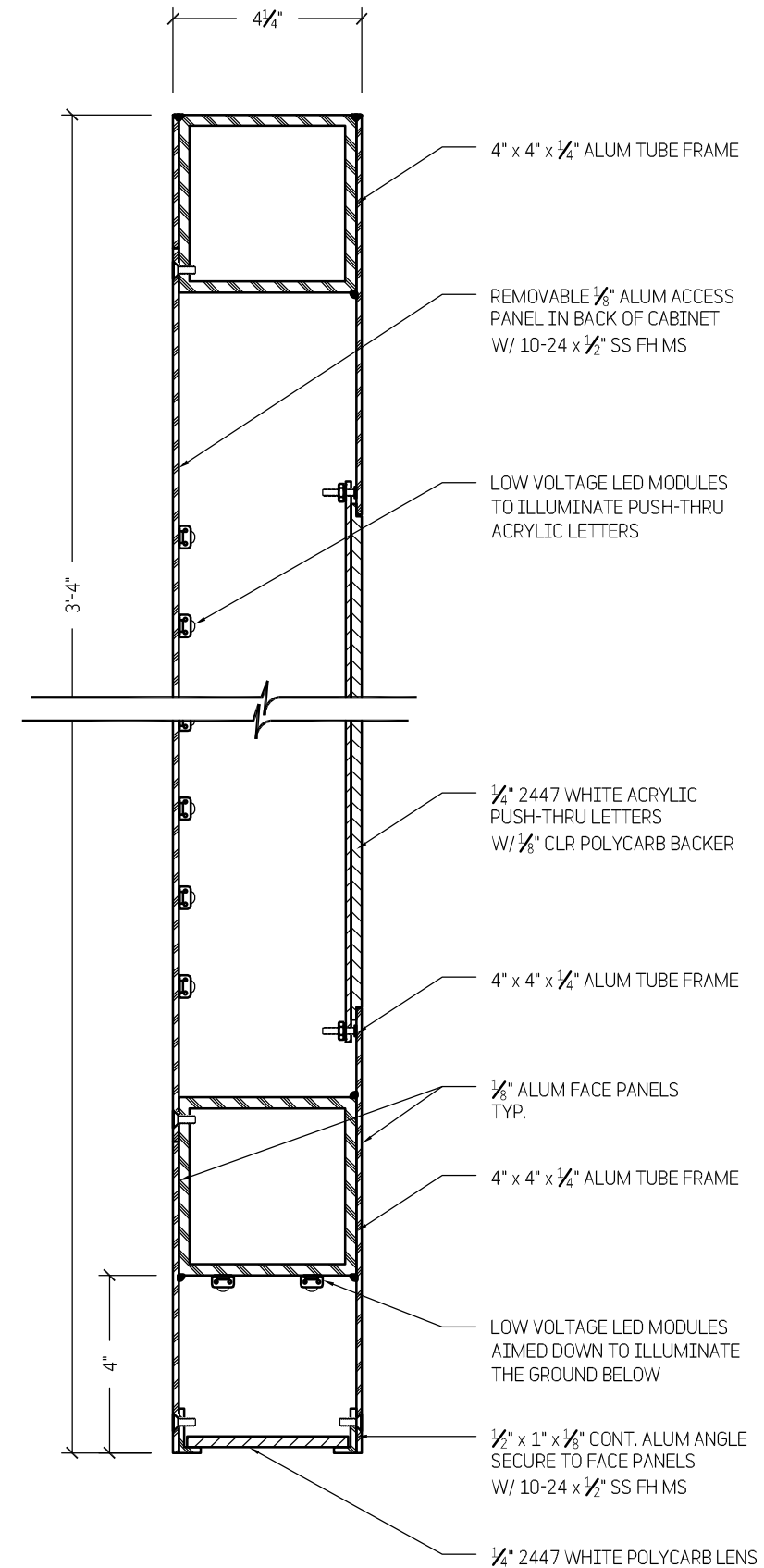

B SECTION
3" - 1'-0"

TWO TWELVE

902 BROADWAY
FLOOR 20
NEW YORK, NY
10010/6002
212 254/6670 T
212 254/6614 F

For Planning & Coordination Only –
Not for Construction

This document and the entirety of its contents are property of 212/Harakawa Inc. and/or Two Twelve Associates, Inc. No part of this document shall be duplicated, disseminated, distributed or used for any purpose without express written permission.

Do not use for final construction. Sign fabricator to verify and be responsible for all dimensions and work conditions and inform this office of variations prior to performing work. Written dimensions govern over scaled dimensions.

No.	Revisions

Date 15 May 2017

Project No. UCONN-046

Phase CID

Project Title

University of Connecticut
Campus Wayfinding

Sign Type R
Emergency ID

CID.111

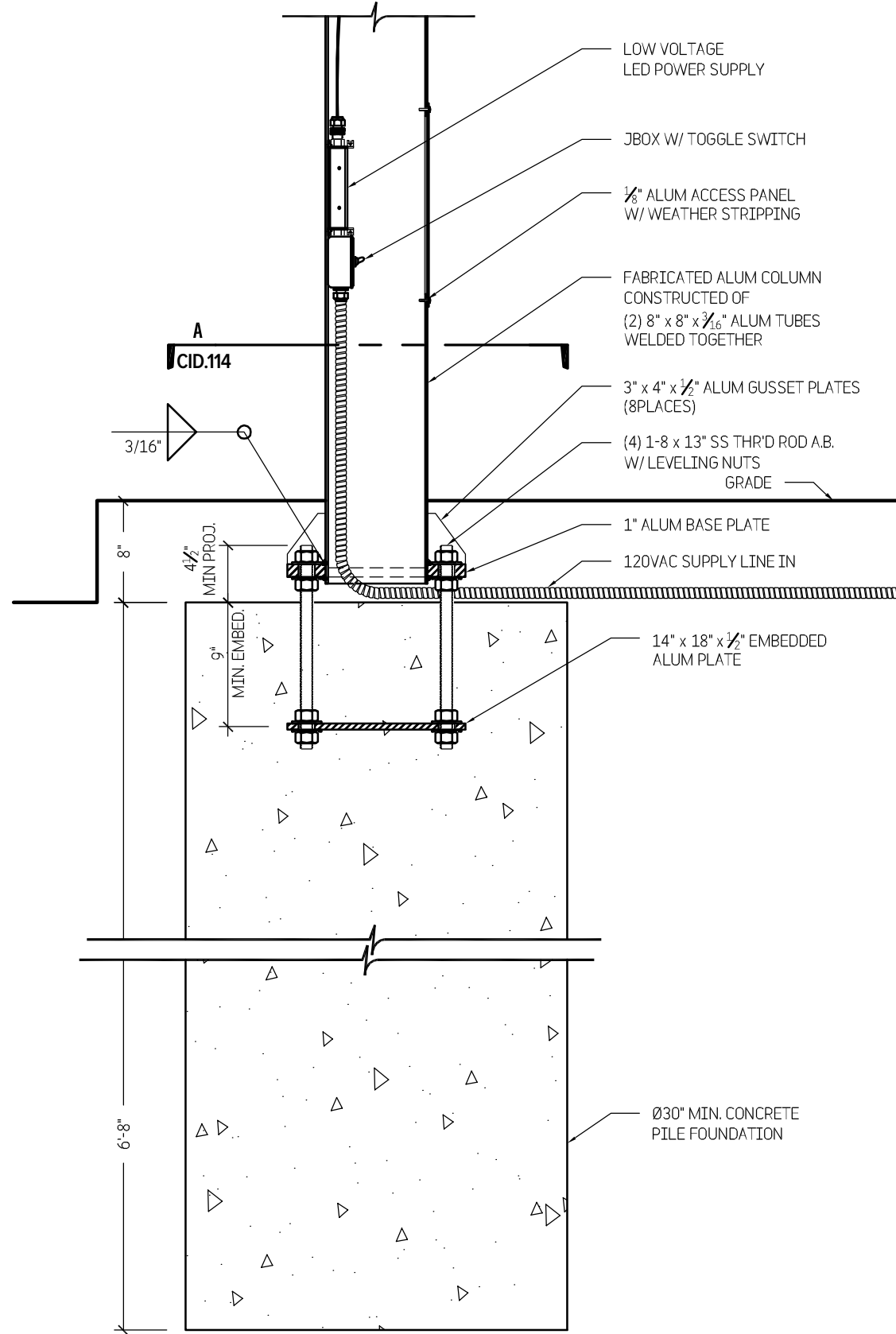

1 DETAIL
1" = 1'-0"

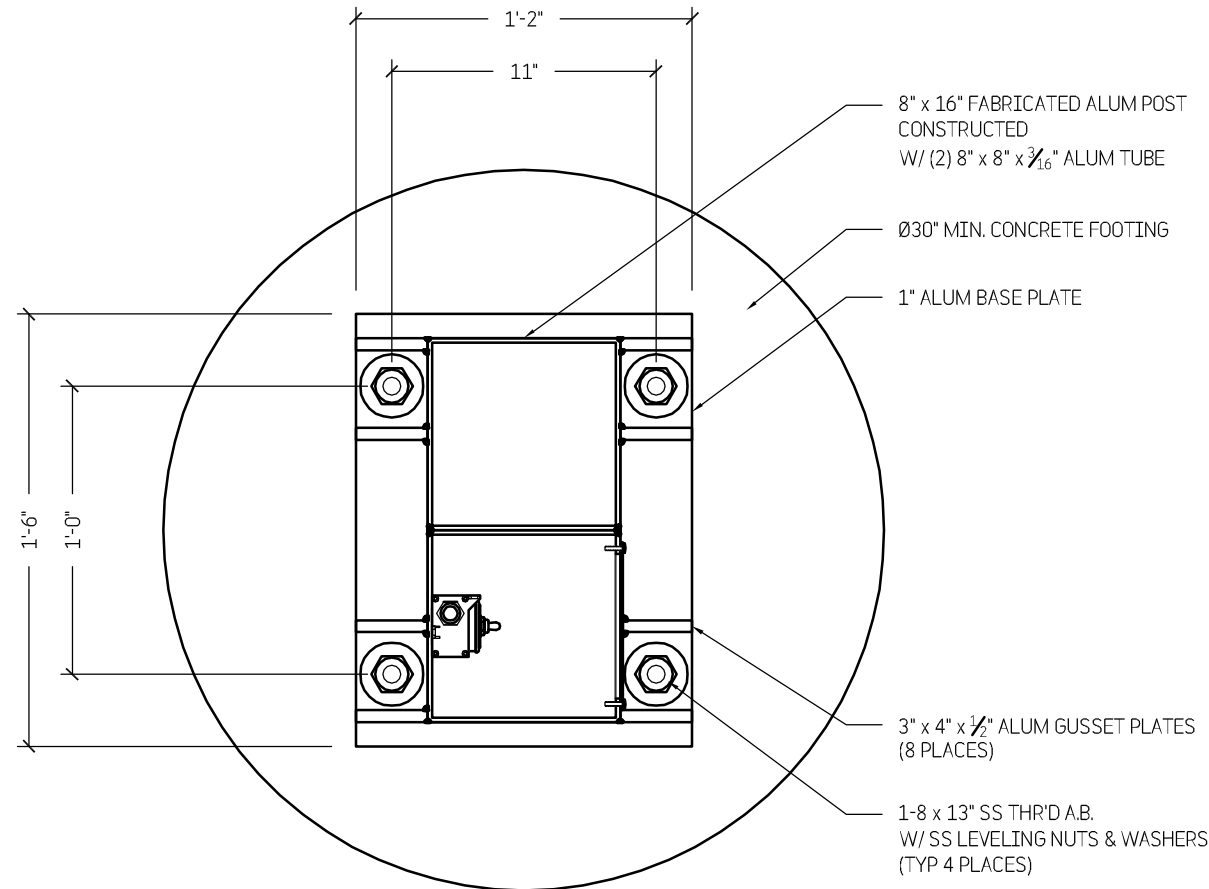

A SECTION
1 1/2" = 1'-0"

TWO TWELVE

902 BROADWAY
FLOOR 20
NEW YORK, NY
10010/6002
212 254/6670 T
212 254/6614 F

For Planning & Coordination Only –
Not for Construction

This document and the entirety of its contents are property of 212/Harakawa Inc. and/or Two Twelve Associates, Inc. No part of this document shall be duplicated, disseminated, distributed or used for any purpose without express written permission.

Do not use for final construction. Sign fabricator to verify and be responsible for all dimensions and work conditions and inform this office of variations prior to performing work. Written dimensions govern over scaled dimensions.

No.	Revisions

Date 15 May 2017

Project No. UCONN-046

Phase CID

Project Title
University of Connecticut
Campus Wayfinding

Sign Type R
Emergency ID

CID.112

Additional Details

- 4.01 No-Mow Zone
- 4.02 ADA Caning Element

No-Mow Zone

To protect and ensure their longterm visibility, all signs shall have a designated zone around with them with softscape elements, such as wood chips, gravel, or riverstone. This discourages growth of natural vegetation, as well as lawn mowers from approaching and potentially damaging the sign.

Should the Owner wish to incorporate plantings in front of the sign, such elements should not exceed 1'-2" in height to ensure that the sign panel is fully visible.

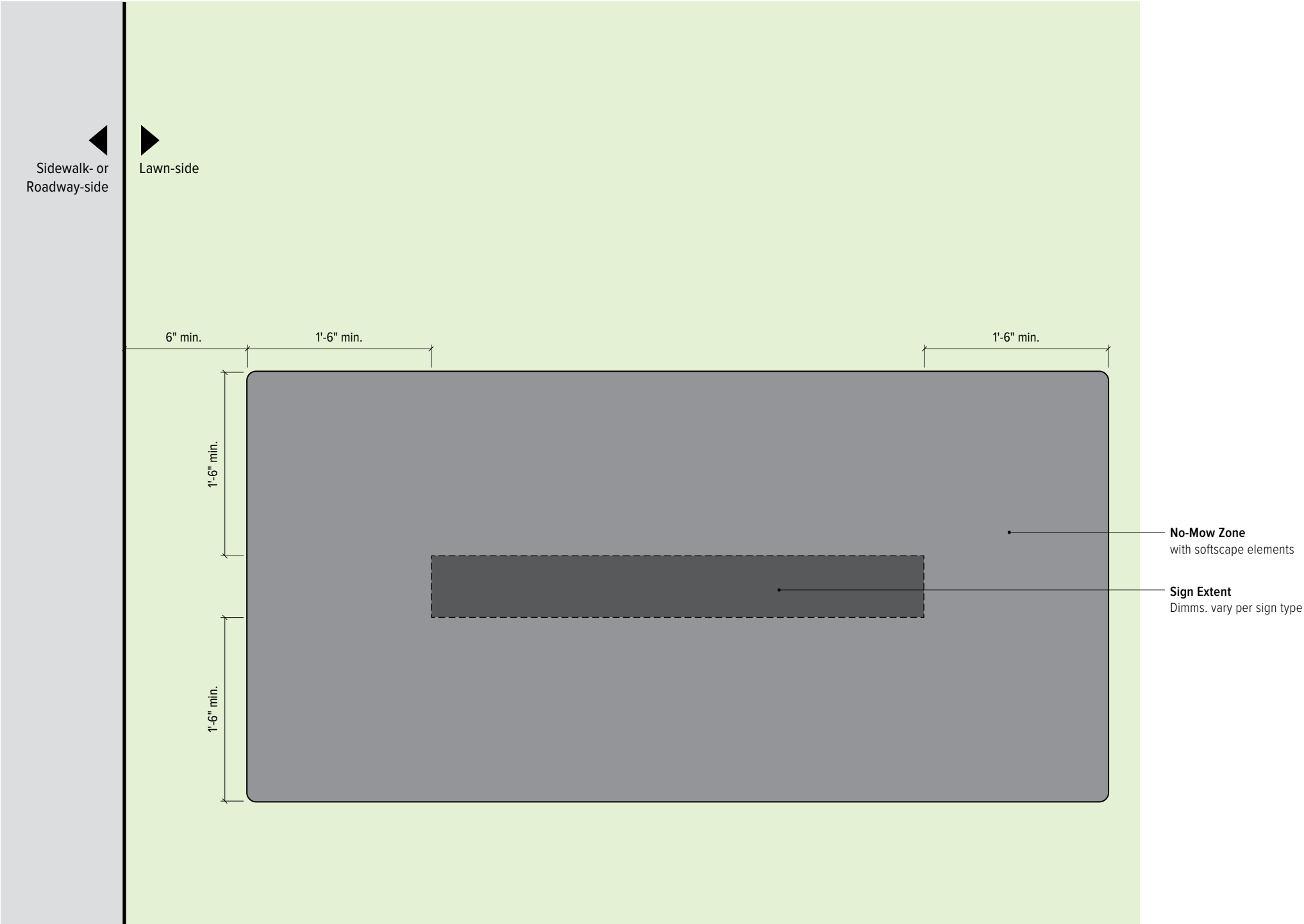

1 Installation Plan - No-Mow Zone

1" = 1'-0"

ADA Caning Bar

Pedestrian directional and orientation sign types (G, H1, H2) that are situated on pedestrian pathways should include an ADA Caning Bar. This enables visually-impaired persons, navigating by cane, to detect protruding signage elements in the field. Implementation of this element should be coordinated with masonry, as required.

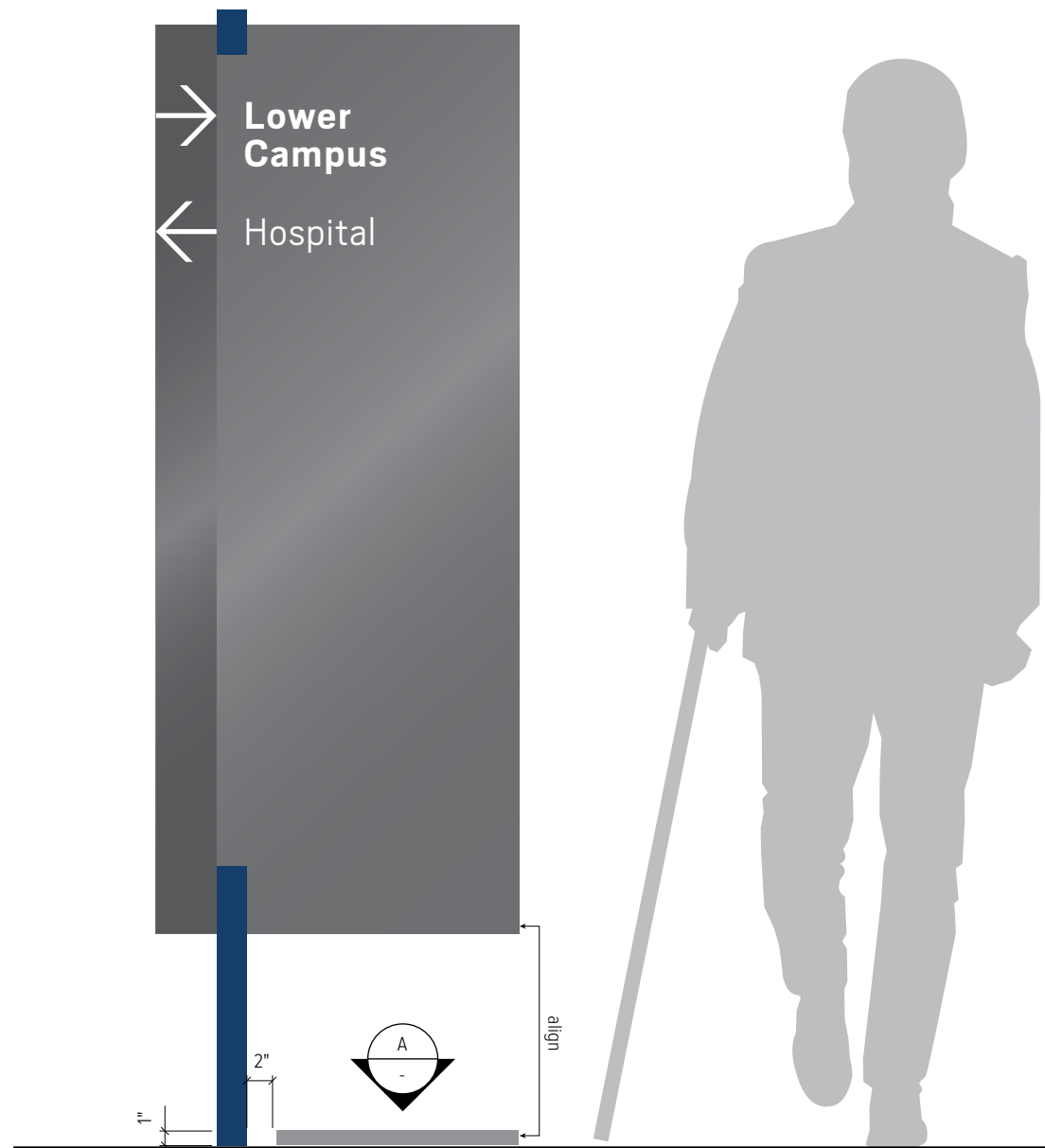

1 Installation Plan - Pedestrian Sign with ADA Caning Bar
1" = 1'-0"

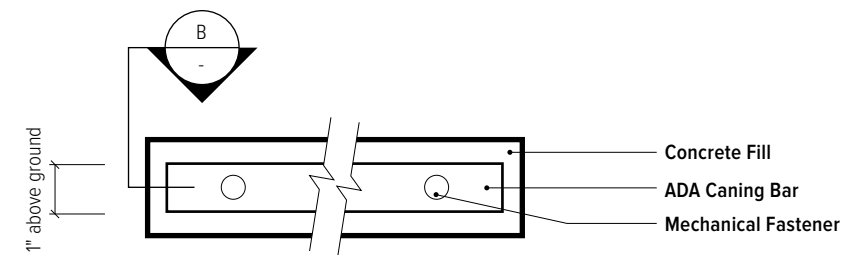

A Detail Plan - ADA Caning Bar
3" = 1'-0"

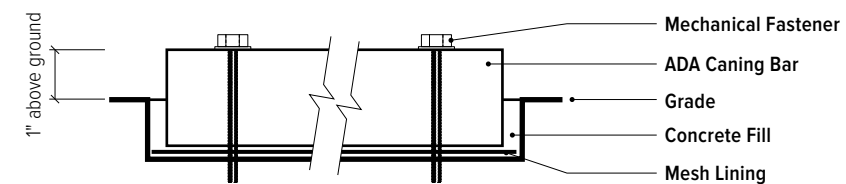

B Detail Section - ADA Caning Bar
3" = 1'-0"

